

P5515, P5515-V, & P5515-EP

Hydraulic Comparison Test Pump

Users Manual

LIMITED WARRANTY AND LIMITATION OF LIABILITY

Each Fluke product is warranted to be free from defects in material and workmanship under normal use and service. The warranty period is one year and begins on the date of shipment. Parts, product repairs, and services are warranted for 90 days. This warranty extends only to the original buyer or end-user customer of a Fluke authorized reseller, and does not apply to fuses, disposable batteries, or to any product which, in Fluke's opinion, has been misused, altered, neglected, contaminated, or damaged by accident or abnormal conditions of operation or handling. Fluke warrants that software will operate substantially in accordance with its functional specifications for 90 days and that it has been properly recorded on non-defective media. Fluke does not warrant that software will be error free or operate without interruption.

Fluke authorized resellers shall extend this warranty on new and unused products to end-user customers only but have no authority to extend a greater or different warranty on behalf of Fluke. Warranty support is available only if product is purchased through a Fluke authorized sales outlet or Buyer has paid the applicable international price. Fluke reserves the right to invoice Buyer for importation costs of repair/replacement parts when product purchased in one country is submitted for repair in another country.

Fluke's warranty obligation is limited, at Fluke's option, to refund of the purchase price, free of charge repair, or replacement of a defective product which is returned to a Fluke authorized service center within the warranty period.

To obtain warranty service, contact your nearest Fluke authorized service center to obtain return authorization information, then send the product to that service center, with a description of the difficulty, postage and insurance prepaid (FOB Destination). Fluke assumes no risk for damage in transit. Following warranty repair, the product will be returned to Buyer, transportation prepaid (FOB Destination). If Fluke determines that failure was caused by neglect, misuse, contamination, alteration, accident, or abnormal condition of operation or handling, including overvoltage failures caused by use outside the product's specified rating, or normal wear and tear of mechanical components, Fluke will provide an estimate of repair costs and obtain authorization before commencing the work. Following repair, the product will be returned to the Buyer transportation prepaid and the Buyer will be billed for the repair and return transportation charges (FOB Shipping Point).

THIS WARRANTY IS BUYER'S SOLE AND EXCLUSIVE REMEDY AND IS IN LIEU OF ALL OTHER WARRANTIES, EXPRESS OR IMPLIED, INCLUDING BUT NOT LIMITED TO ANY IMPLIED WARRANTY OF MERCHANTABILITY OR FITNESS FOR A PARTICULAR PURPOSE. FLUKE SHALL NOT BE LIABLE FOR ANY SPECIAL, INDIRECT, INCIDENTAL, OR CONSEQUENTIAL DAMAGES OR LOSSES, INCLUDING LOSS OF DATA, ARISING FROM ANY CAUSE OR THEORY.

Since some countries or states do not allow limitation of the term of an implied warranty, or exclusion or limitation of incidental or consequential damages, the limitations and exclusions of this warranty may not apply to every buyer. If any provision of this Warranty is held invalid or unenforceable by a court or other decision-maker of competent jurisdiction, such holding will not affect the validity or enforceability of any other provision.

Fluke Corporation
P.O. Box 9090
Everett, WA 98206-9090
U.S.A.

Fluke Europe B.V.
P.O. Box 1186
5602 BD Eindhoven
The Netherlands

11/99

To register your product online, visit register.fluke.com

Table of Contents

Title	Page
Introduction.....	1
How to Contact Fluke.....	2
Safety Information.....	2
Safety Summary.....	2
Compressed Liquid.....	2
Personal Protective Equipment.....	2
Symbols Used in this Manual.....	2
Preparation.....	3
Operating Fluid Compatibility.....	3
Connections.....	3
Test Port Insert.....	7
Priming.....	7
Operation.....	8
Maintenance and Servicing.....	8
Top Plate Removal.....	8
Screw Pump Assembly.....	9
Priming Pump Assembly.....	11
Disassembly.....	11
Reassembly.....	11
Check Valves.....	13
Inlet Check Valve.....	13
Outlet Check Valve.....	13
Reservoir Assembly.....	14
Fault Finding.....	16
System Will Not Prime.....	16
System Will Not Pressurize.....	16
Priming Pump Malfunction.....	17
Cannot Reach Maximum Pressure.....	17
Pressure Falls Away.....	17
Storage and Transportation.....	17
Ancillary Equipment.....	18
Angle Adapter, P5543.....	18
Pointer Remover/Punch, P5551.....	18
Liquid Separator, P5521.....	19

List of Tables

Table	Title	Page
1.	Symbols.....	3
2.	Increased Fluid Compatibility Models.....	3
3.	Test Port Insert - Parts.....	7
4.	Screw Pump Assembly - Parts List.....	10
5.	Priming Pump Assembly - Parts List.....	13
6.	Check Valve Assemblies - Parts List.....	14
7.	Reservoir Assembly - Parts List.....	16

List of Figures

Figure	Title	Page
1.	Hydraulic Circuit Schematic	1
2.	Screw on Gauge Adapter.....	4
3.	Mount Gauge.....	5
4.	Adjust Gauge Position.....	5
5.	Tighten Gauge	6
6.	Do Not Over-Tighten	6
7.	Test Port Insert	7
8.	Screw Pump Assembly	10
9.	Priming Pump Assembly.....	12
10.	Check Valve Assemblies.....	14
11.	Reservoir Assembly	15
12.	Angle Adapter	18
13.	Pointer Remover/Punch.....	18
14.	Liquid Separator	19

Introduction

This manual contains operation and routine and preventive maintenance instructions for the Model P5515, P5515-V, and P5515-EP Hydraulic Comparison Test Pump. The manual will refer to all model numbers of the instrument listed above generically as a Model P5515, unless denoted as only applicable to a specific model number.

The Comparison Test Pump is used for checking pressure-measuring instruments against Master Test Gauges.

Note

The terms "Master Test Gauge" and "Gauge" in this document refer to any pressure-measuring instrument such as Transfer Standards, Digital Calibrators, and Transducers.

This system is only as accurate as the Master Test Gauge used. The Master Test Gauge must be regularly calibrated on a Primary Reference Standard (such as a Deadweight Tester) to ensure accuracy is maintained.

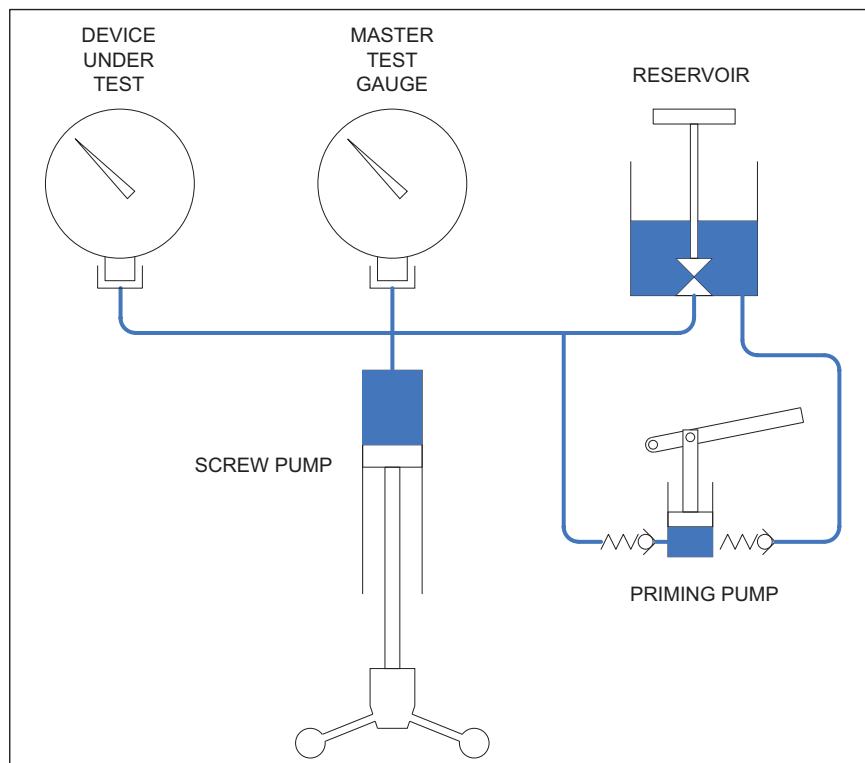

Figure 1. Hydraulic Circuit Schematic

gkx01.eps

How to Contact Fluke

To order accessories, receive operating assistance, or get the location of the nearest Fluke distributor or Service Center, call:

- Technical Support USA: 1-800-99-FLUKE (1-800-993-5853)
- Calibration/Repair USA: 1-888-99-FLUKE (1-888-993-5853)
- Canada: 1-800-36-FLUKE (1-800-363-5853)
- Europe: +31-402-675-200
- China: +86-400-810-3435
- Japan: +81-3-3434-0181
- Singapore: +65-738-5655
- Anywhere in the world: +1-425-446-5500

Or, visit Fluke's website at www.fluke.com.

To register your product, visit <http://register.fluke.com>.

To view, print, or download the latest manual supplement, visit <http://us.fluke.com/usen/support/manuals>.

Safety Information

Safety Summary

The following are general safety precautions that are not related to any specific procedures and do not appear elsewhere in this publication. These are recommended precautions that personnel must understand and apply during equipment operation and maintenance to ensure safety and health and protection of property.

Warning

If the equipment is used in a manner not specified by the manufacturer, the protection provided by the equipment may be impaired.

Compressed Liquid

Use of compressed liquids can create an environment of propelled foreign matter. Pressure system safety precautions apply to all ranges of pressure. Care must be taken during testing to ensure that all hydraulic connections are properly and tightly made prior to applying pressure. Personnel must wear eye protection to prevent injury.

Personal Protective Equipment



Wear eye protection approved for the materials and tools being used.

Symbols Used in this Manual

In this manual, a **Warning** identifies conditions and actions that pose a hazard to the user. A **Caution** identifies conditions and actions that may damage the Hydraulic Comparison Test Pump.

Symbols used on the Hydraulic Comparison Test Pump and in this manual are explained in 1.

Table 1. Symbols

Symbol	Description
~	AC (Alternating Current)
	Earth Ground
	Important Information: refer to manual
	Do not dispose of this product as unsorted municipal waste. Go to Fluke's website for recycling information.

Preparation

The comparison test pump must be set up on a level, stable workbench or similar surface.

Remove spokes from tool roll and fit to capstan hub.

Level the tester using the four adjustable feet to prevent “rocking”.

Rotate reservoir dust cover through ¼ turn and fill reservoir approximately ¾ full with the appropriate fluid. Rotate dust cover back to cover hole.

Caution

To avoid damage to the instrument, the operator should check the quality of the operating fluid during use. If the fluid becomes discolored, cloudy or particles appear in the reservoir, the system should be drained and flushed with clean fluid.

Operating Fluid Compatibility

Caution

The standard system is designed for use with a wide range of fluids, however, the reservoir tube is Acrylic, and the O-ring seals are Nitrile; use of solvents, fuel oils, brake fluids or other, similar aggressive fluids can damage the seals and the reservoir tube.

The table below details the two alternative versions of this instrument, which offer increased compatibility with other fluids.

Table 2. Increased Fluid Compatibility Models

Model	O Rings	Reservoir Tube
P5515	Nitrile	Acrylic
P5515-V	Viton	Anodized Aluminum
P5515-EP	Ethylene Propylene	Anodized Aluminum

Connections

Fit the device under test (DUT) to the test port using the method described below:

Caution

Ensure that all devices are internally clean and free from contamination before connecting to the tester.

Particle contamination can damage the sensitive piston assemblies, valve seats and screw pump.

To avoid cross-contamination from other fluids, and protect the system from particulates, we recommend the use of a Liquid Separator, (refer to section Ancillary Equipment).

⚠ Warning

DO NOT use Teflon/PTFE tape on these connections, as this will prevent correct sealing. The Gauge Adapter sealing system is designed for hand-tight sealing up to 20,000 psi / 1,400 bar-wrenches or similar tools are not required — over tightening can cause damage to threads or sealing faces.

Before connection, ensure that there is an O-ring fitted to the test port.

Check that the sealing face of the device to be fitted is clean and undamaged, as scratches or dents can form leak-paths.

Note

The thread on the test port, and the lower part of the gauge adapters is LEFT-HANDED. The following procedure details the correct method for mounting devices using these adapters.

1. Screw the appropriate gauge adapter fully on to the instrument to be tested.

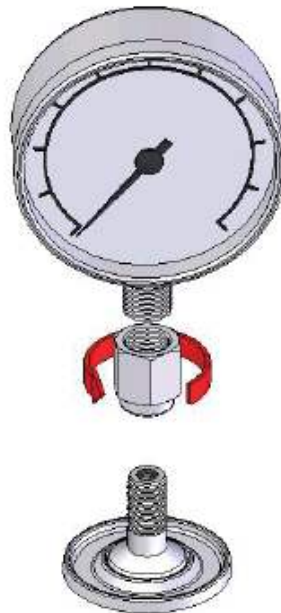

Figure 2. Screw on Gauge Adapter

gkx02.bmp

2. Screw assembly down COUNTER-CLOCKWISE on to test port.

Note

Hand-tight is sufficient; ensure that the bottom face contacts the O-ring on the test port.



Figure 3. Mount Gauge

glx03.bmp

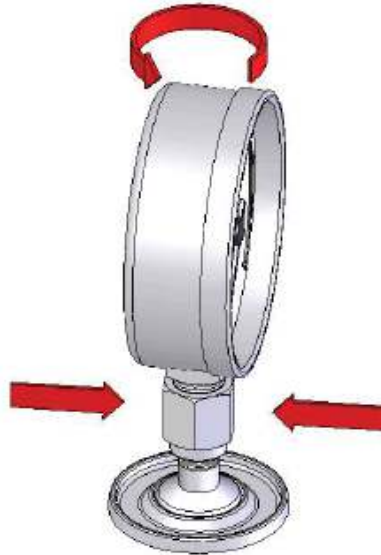

Figure 4. Adjust Gauge Position

glx05.bmp

3. To adjust the position to face forward, hold the gauge adapter and turn the instrument COUNTER-CLOCKWISE, so that it faces forward.

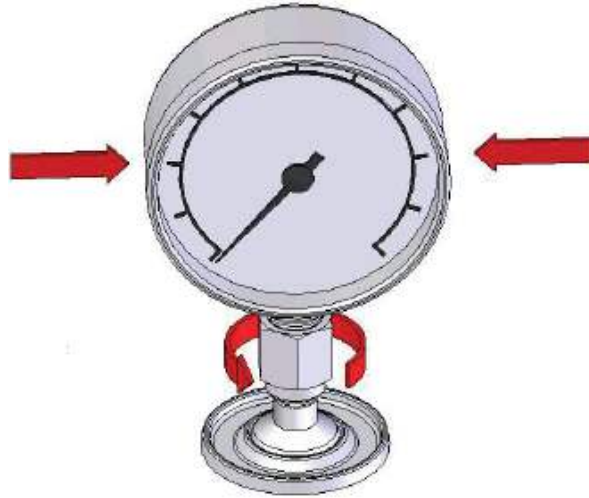

Figure 5. Tighten Gauge

gkx06.bmp

4. Hold the instrument steady, while turning the gauge adapter COUNTER-CLOCKWISE until it pulls down onto the O-ring.



Figure 6. Do Not Over-Tighten

gkx07.bmp

Test Port Insert

For devices with 1/8 BSP or NPT mounting threads, the diameter of the thread is very close to the effective sealing diameter of the O-ring fitted to the test port.

This can make it difficult to achieve a good seal. When mounting these devices, use the test port insert (stored in the spare seals container) as shown in Figure 7.

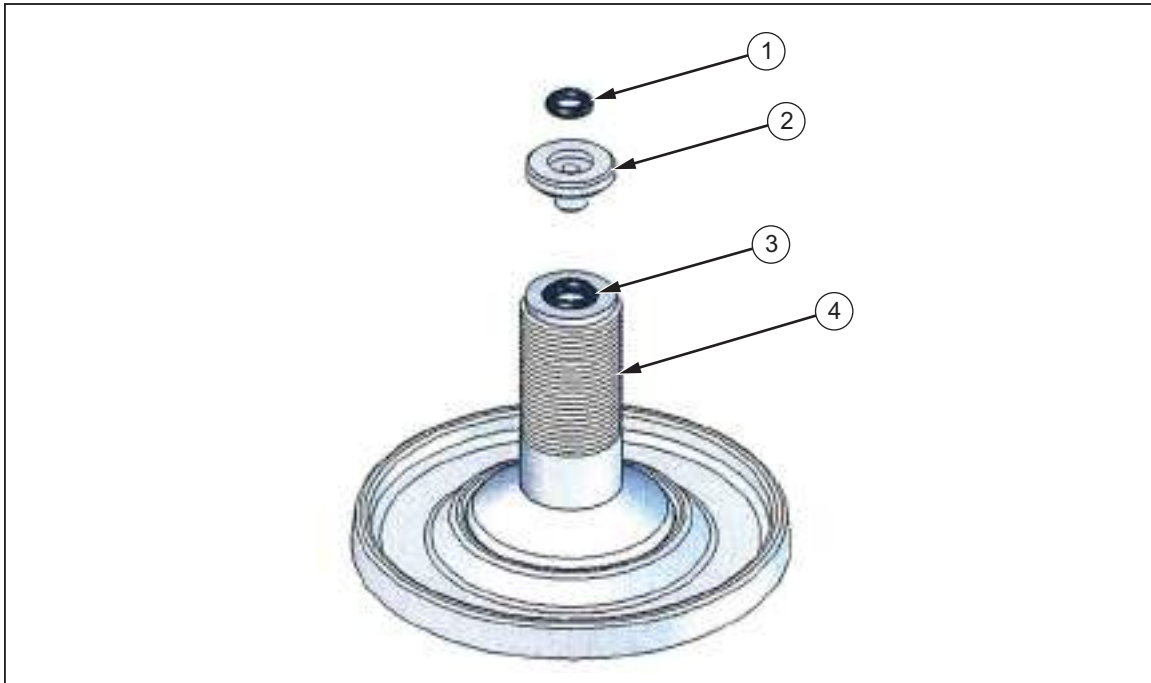

Figure 7. Test Port Insert

gjn012.eps

Table 3. Test Port Insert - Parts

Item	Description	Part		
		P5515	P5515-V	P5515-EP
1	O Ring	3865142	3865163	3867888
2	Test Port Insert	3919892		
3	O Ring	3883397	3883521	3867895
4	Test Port	3921414		

To calibrate panel-mounted gauges with pressure connections in the rear, use an Angle Adapter (see Chapter 8, Ancillary Equipment).

Priming

1. Open reservoir valve one turn counter-clockwise and turn capstan fully in.
2. Pump the priming pump two times.
3. Close valve (see caution below) and turn capstan fully out.
4. Open valve and turn capstan fully in.

Note

During this operation, bubbles may appear in the reservoir, as trapped air is expelled. For large volumes, repeat steps 3 & 4 until no further bubbles appear.

5. With valve open, turn capstan fully out and close valve. The tester is now ready for use.

⚠ Warning

Turning the capstan out with the reservoir valve closed will generate approximately 15 inHg / 0.5 bar vacuum. If the DUT is vacuum sensitive, leave valve open during priming operation.

Operation

1. Turn the screw press in (clockwise) to generate pressure.

Note

The priming pump is intended for system priming only, and cannot be used to generate high pressures.

2. Allow a few moments for the system to stabilize before taking any readings, especially after large changes in system pressure.

Note

Large, sudden changes in pressure will cause the system temperature to rise or fall, which can cause instrument readings to change as the fluid in the system expands or contracts, thus increasing or decreasing the pressure.

3. Compare the reading of the gauge under test with that of the master gauge.
4. For the next, higher calibration point, repeat from step 1 above.
5. To measure reducing pressures, turn the screw press out (counter-clockwise).
6. Depressurize the system by turning the screw press FULLY OUT, then open the reservoir valve—

⚠ Caution

Never release the system pressure by using the reservoir valve alone, as sudden depressurization will “shock” the system, which may cause damage to sensitive instruments attached to it.

Maintenance and Servicing

The figures on the following pages detail the components of each assembly, together with the relevant part numbers. Where “SPEC” appears as a part number, this indicates that this particular component varies with the specification of the comparison test pump, and is usually associated with other components in an assembly for replacement purposes. The part number for the seal kit for the P5515, P5515-V, and P5515-EP is P5515SK, P5515SK-V, and P5515SK-EP, respectively.

Top Plate Removal

1. Depressurize the system, open the reservoir valve, and turn the screw press fully in.
2. Disconnect any DUT from the test ports, and drain the fluid from the system; the reservoir is fitted with a drain plug, which can be accessed from the underside of the instrument, see Chapter 5, Reserve Assembly.

3. Remove the spokes from the hub on the front of the instrument.
4. Remove the 4 screws from the instrument top plate, (1 at the mid-point of each edge).
5. Hold the top plate assembly by the test port, and tilt the plate so that the rear edge is lifted, but the front edge remains in contact with the instrument case.
6. Slide the top plate towards the rear until the capstan hub is clear of the front lip of the instrument case.
7. Lift out the top plate assembly.

Screw Pump Assembly

1. Unscrew the large union nut (just behind the inner hub) of the screw press assembly.
2. Withdraw the lead screw assembly from the barrel (4), taking care not to drop the rambler assembly (8).
3. The white, anti-extrusion ring (7) is a PTFE spiral, and can be removed by “unwinding” it from the rambler.
4. When removing the rambler seal (6), take care not to use any tool that may have a sharp edge that will scratch the surfaces of the rambler, otherwise it may leak when reassembled.
5. The replacement rambler seal can be eased over the front of the rambler, and into the groove.
6. Similarly, the new anti-extrusion ring can be “wound” into the groove in the rambler, behind the rambler seal.
7. If it is necessary to remove the barrel (4), the locknut (3) must be loosened approximately ½ turn. The barrel can then be unscrewed from the test station (1).

Note

It is often easier to remove the barrel support bracket (5) to allow greater movement, (remove the 2 screws from the upper side of the top plate).

8. Before re-fitting the barrel, ensure that the barrel seal (2) is correctly located in the counter-bore in the front of the barrel. Screw the barrel fully in to the test station, and secure with the locknut.
9. Re-align the barrel support bracket (if removed), and secure through the top plate with the 2 screws.
10. Ensure that the rambler assembly is correctly located on the end of the lead screw assembly. Carefully introduce the rambler into the open end of the barrel; making sure that it does not tilt when entering the barrel.
11. Push the lead screw assembly fully in to the barrel, ensuring that the key in the nut locates correctly in the slot in the barrel.
12. Re-tighten the barrel union nut.

⚠ Caution

If the lead screw assembly shows signs of excessive wear, then it is very likely that the associated components have worn also; therefore, the screw press assembly is available as a spare part — see diagrams for part numbers.

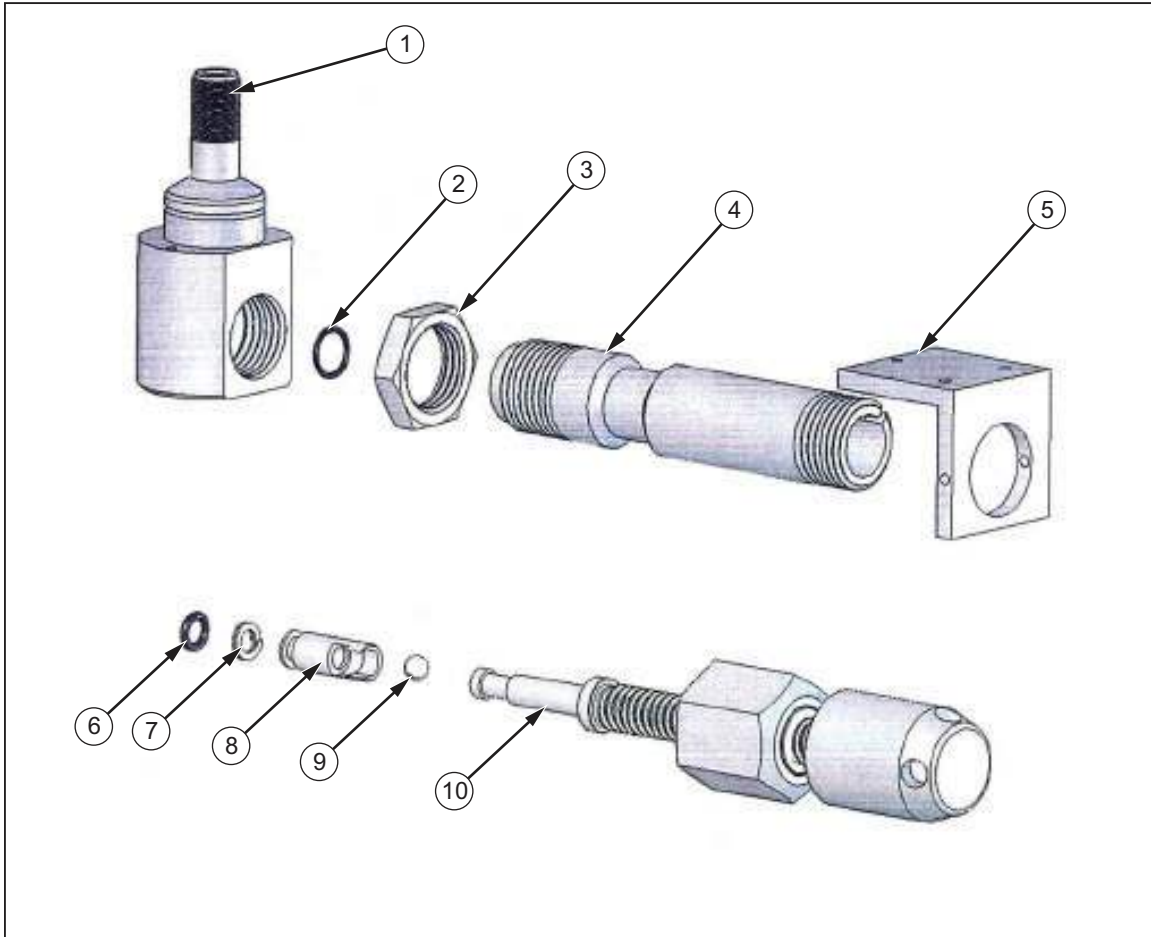

Figure 8. Screw Pump Assembly

gkx09.eps

Table 4. Screw Pump Assembly - Parts List

Item	Description	Part		
		P5515	P5515-V	P5515-EP
1	Test Port	3921414		
2	O Ring	3864922	3865332	3865565
3	Barrel Locknut	3921438		
4	Barrel	3921450		
5	Barrel Support	3821492		
6	O Ring	3867566	3867920	3867901
7	Back-Up Ring	3919118		
8	Rambler	3919129		
9	Ball	3917855		
10	Lead Screw Assembly	3885994		

Priming Pump Assembly

Disassembly

1. On the underside of the top plate, disconnect the hydraulic tubing from the pump block assembly (14).
2. On the upper side of the top plate, unscrew locknut (3) ½ turn, and remove clip pin from clevis (2).
3. The pump arm assembly can be swung out of the way.
4. Remove locknut (3) and clevis (2).
5. Unscrew union nut (4), and withdraw pump assembly from below the top plate.
6. Withdraw pump shaft (6), taking care not to drop shaft bearing (5) or rambler assembly (8).
7. The white, anti-extrusion ring (9) is a PTFE spiral, and can be removed by “unwinding” it from the rambler.
8. When removing the rambler seal (10), take care not to use any tool that may have a sharp edge that will scratch the surfaces of the groove in the rambler, otherwise it may leak when reassembled.
9. The replacement rambler seal can be eased over the front of the rambler, and into the groove.
10. Similarly, the new anti-extrusion ring can be “wound” into the groove in the rambler, behind the rambler seal.
11. If it is necessary to remove the barrel (12), the locknut (11) must be loosened approximately ½ turn. The barrel can then be unscrewed from the pump block assembly (14).

Reassembly

1. Before re-fitting the barrel, ensure that the O-ring (13) is correctly located in the counter-bore in the front of the barrel. Screw the barrel fully in to the test station, and secure with the locknut.
2. Ensure that the rambler assembly is correctly located on the end of the pump shaft. Carefully introduce the rambler into the open end of the barrel; making sure that it does not tilt when entering the barrel.
3. Slide the pump bearing (5) over the shaft, and locate it inside the barrel.
4. Re-introduce the pump assembly from the underside of the top plate, and secure with the union nut (4).
5. Replace locknut (3) and clevis (2), reconnect pump arm assembly, and secure with pin clip.
6. Reconnect hydraulic tubing.

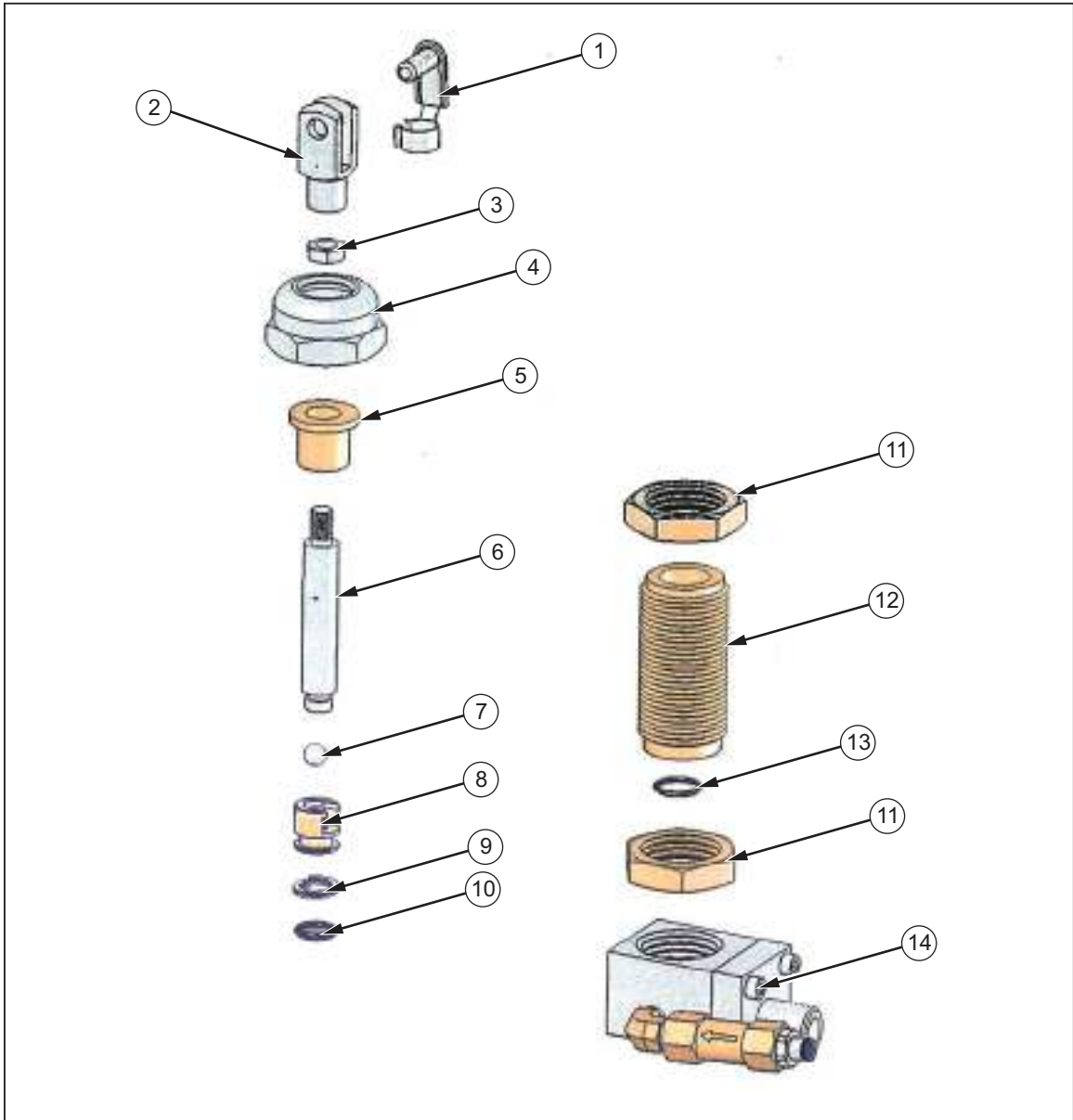

Figure 9. Priming Pump Assembly

gkx10.eps

Table 5. Priming Pump Assembly - Parts List

Item	Description	Part		
		P5515	P5515-V	P5515-EP
1	Pivot Clip	3920224		
2	Clevis	3920236		
3	Locknut	3918713		
4	Pump Union Nut	3921527		
5	Shaft Bearing	3867744		
6	Pump Shaft	3921509		
7	Ball	3917855		
8	Rambler	3919165		
9	Back-Up Ring	3920516		
10	O Ring	3864782	3922070	3865541
11	Barrel Locknut	3921438		
12	Pump Barrel	3921511		
13	O Ring	3864711	3865359	3922004
14	Pump Block Assembly			

Check Valves

Inlet Check Valve

The inlet check valve is a bought-in item, and is not readily user-serviceable.

To remove:

1. Disconnect nylon tubing from connector (10), by pressing in the collar at the top of the connector, and gently pulling on the tubing.
2. Unscrew and remove connector.
3. Remove check valve assembly (9).
4. When replacing the check valve assembly, take care to remove all traces of PTFE or Teflon sealing tape on the mating threads of elbow (7). New tape (or similar sealing method) must be applied to ensure a pressure-tight joint.
5. Reassembly is the reverse of removal.

Outlet Check Valve

6. Remove screws (7) and lift off flange (6), taking care not to drop the check valve bullet (4) and spring (5).
7. Inspect the parts for cleanliness and damage—particularly the sealing surfaces.
8. When removing O-rings, take care not to use any tool that may have a sharp edge that will scratch the surfaces of the mating groove, otherwise it may leak when reassembled.
9. Reassembly is the reverse of removal, but care must be taken to ensure that the spring and bullet are seated correctly.

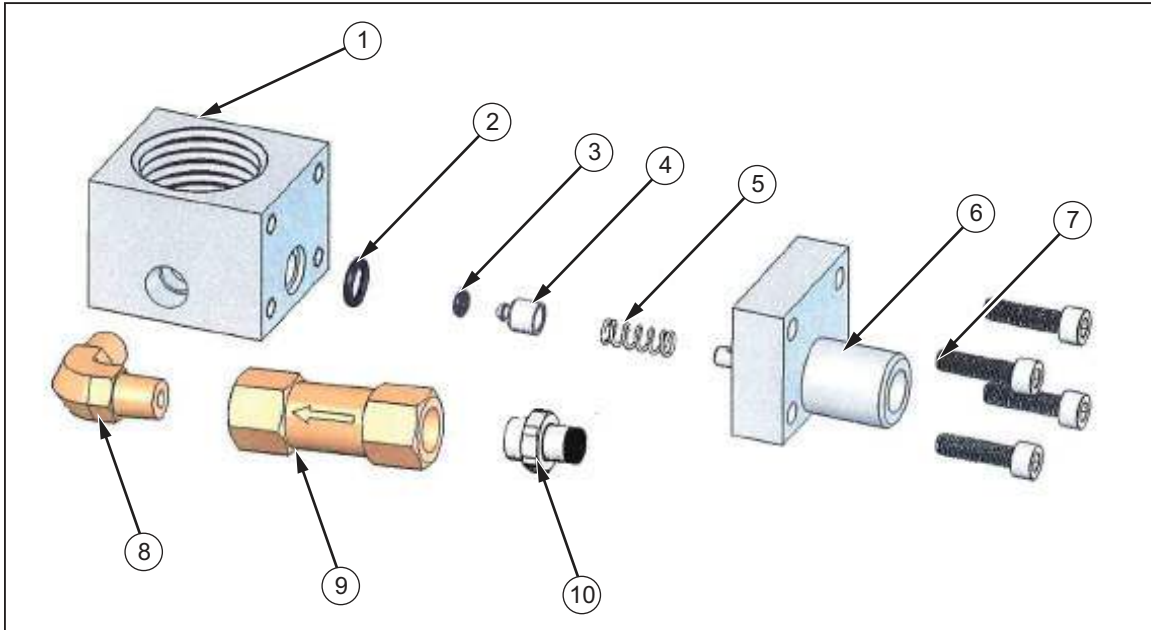

gkx11.eps

Figure 10. Check Valve Assemblies

Table 6. Check Valve Assemblies - Parts List

Item	Description	Part		
		P5515	P5515-V	P5515-EP
1	Pump Block	3921530		
2	O Ring	3864766		
3	O Ring	3867636	3867912	3867874
4	Bullet	3920584		
5	Spring	3920600		
6	Pump Check Flange	3921744		
7	Screw	3909261		
8	Elbow	3862616		
9	Check Valve	3867767	3966453	3966468
10	Connector	3923564		

Reservoir Assembly

1. To drain the fluid from the reservoir, raise the instrument a few inches by placing suitably sized blocks under the feet.
2. Place a suitable catchment tray or bowl below the reservoir drain (15).
3. Open the valve by turning valve stem (1) counter-clockwise.
4. Remove gland nut and plug (15 & 14), and allow the fluid to drop into the catchment tray.

5. To completely disassemble the reservoir, the top plate must be removed from the instrument case.
6. Disconnect the high-pressure tubing by unscrewing the gland nuts fitted to the reservoir body (12).
7. The low pressure feed to the priming pump is disconnected by pressing down on the black plastic ring at the top of the connector, and gently pulling on the nylon tubing.
8. Remove valve stem completely by turning counter-clockwise, taking care not to lose the spring (2) and nylon washer (3).
9. Lift off reservoir cover (4).
10. Remove three screws from reservoir spacers that hold the assembly to the top plate. The assembly can now be withdrawn from the underside of the top plate.
11. The reservoir body (12) and reservoir cap (5) are a close fit to the reservoir tube (7), and both rely on the O-ring seal (6) to hold them in place. These parts can be separated by gently pulling them apart.
12. The valve vent (10) is disassembled from the reservoir body by removing the three screws (8).
13. Reassembly is the reverse of the above procedure.

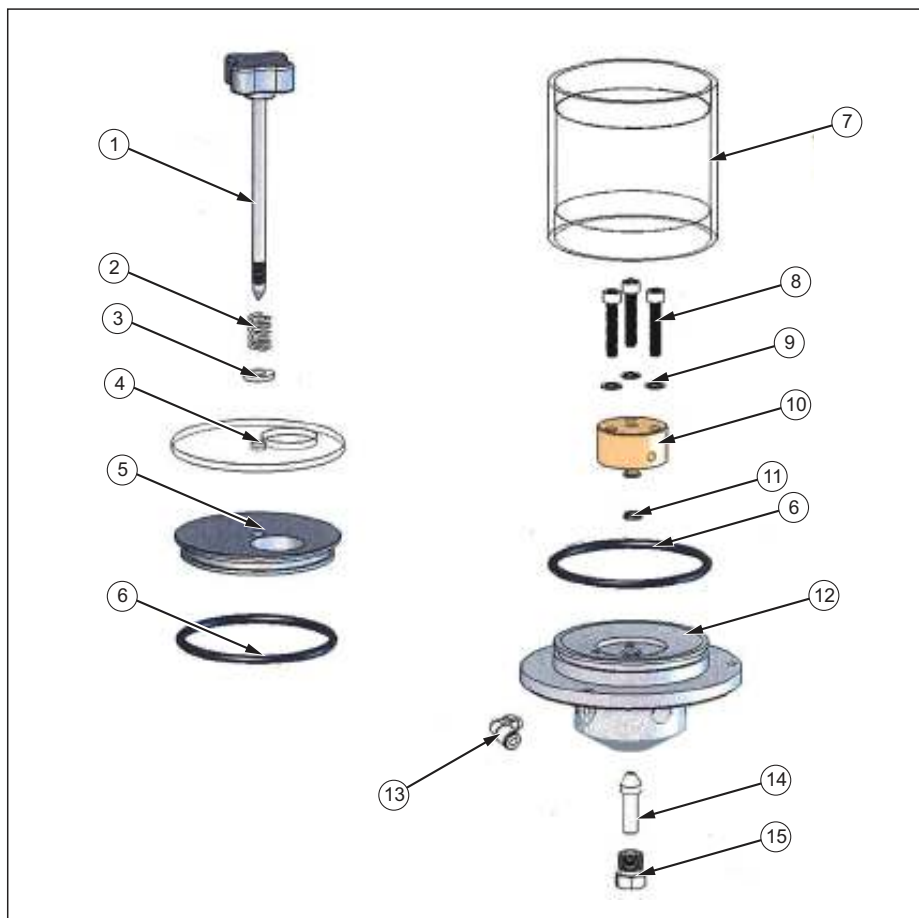

Figure 11. Reservoir Assembly

gkx12.eps

Table 7. Reservoir Assembly - Parts List

Item	Description	Part		
		P5515	P5515-V	P5515-EP
1	VALVE STEM	3886430		
2	SPRING	3922786		
3	NYLON WASHER	3916458		
4	RESERVOIR COVER	3921624		
5	RESERVOIR CAP	3921613		
6	O RING	3864910	3865326	3865552
7	RESERVOIR TUBE	3921608	3921726	3921726
8	SCREW	3909292		
9	WASHER	3205770		
10	VALVE VENT	3921582		
11	O RING	3865142	3865163	3867888
12	RESERVOIR BODY	3921575		
13	ELBOW	3926855		
14	PLUG	3068437		
15	GLAND NUT	3903089		

Fault Finding

System Will Not Prime

1. Check reservoir valve is closed.
2. Check for sufficient fluid in reservoir.
3. Check for damaged/missing/dirty O-ring on test ports.
4. Check that the face of the DUT is contacting the O-ring, and that the surface is not scored or dented.

System Will Not Pressurize

1. Ensure correct valve operation during priming process.
2. Check DUT is not leaking.
3. Clean system externally, check for fluid leak by continually trying to pressurize. Wherever fluid appears, replace the seal — check sealing faces are clean and undamaged before re-assembly.
4. Check that the face of the DUT is contacting the O-ring, and that the surface is not scored or dented.

Priming Pump Malfunction

1. If pumping does not generate pressure, then the inlet check valve has probably failed, and requires replacement.
2. If the system pressurizes and depressurizes in conjunction with the downward and upward strokes of the pump, then the outlet check valve has failed completely. This should be disassembled and inspected for dirt or damage to valve seat and seal. After inspection, clean all parts carefully, replace as required, and re-assemble correctly.
3. If the pump handle rises during normal system pressurization, then the outlet check valve is leaking. Inspect as above.

⚠ Caution

Do not continue to pressurize if pump handle rises, as this can damage the inlet check valve.

Cannot Reach Maximum Pressure

If maximum pressure cannot be reached, even after the screw press has been turned fully in, and the checks above have been made:

1. Ensure that the screw press is FULLY OUT, and the priming pump is used for initial pressurization.
2. If the DUT has a large internal volume or there is air in the system, then re-prime (Refer to Chapter 3), increasing the initial pressurization with the priming pump from 100 psi/7 bar to at least 200 psi/14 bar.

Pressure Falls Away

Large, sudden changes in pressure will cause the system temperature to rise or fall, which can cause instrument readings to change as the fluid in the system expands or contracts, thus increasing or decreasing the pressure. Allow a few minutes to determine if the system pressure is continuing to fall away, or is stabilizing.

Storage and Transportation

1. With the test port plugged, open the reservoir valve and turn screw press fully in, close reservoir valve.
2. Remove spokes from hub, and store in tool-roll.
3. Remove screw-in handle from pump arm, and store in tool roll.
4. If fluid is to remain in the reservoir, ensure that the tester is kept level at all times to avoid spills. If not, drain the reservoir as described in Chapter 5, Reserve Assembly.
5. Re-fit instrument lid, ensuring that the hinges are correctly engaged, and secure with toggle clips at the sides.

Ancillary Equipment

Angle Adapter, P5543

To calibrate gauges with the pressure connection on the rear (e.g. panel-mount gauges) in their correct position, an angle adapter should be used. The angle adapter fits directly onto the test station, converting it through 90 degrees, allowing the standard adapters to be used.



Figure 12. Angle Adapter

gkx13.bmp

Pointer Remover/Punch, P5551

To remove and refit the pointer of a pressure gauge, use a pointer remover/punch. This tool has a spring-loaded plunger to quickly and consistently refit the pointer.



Figure 13. Pointer Remover/Punch

gkx14.bmp

Liquid Separator, P5521

The Liquid Separator is used to separate the working fluid of the deadweight tester to which it is fitted from the working fluid in the device under test. This prevents contamination of either hydraulic system and allows calibration of the device in its specific working fluid.



Figure 14. Liquid Separator

gkq21.bmp

