

FLUKE®

Calibration

P5513

Pneumatic Comparison Test Pump

Users Manual

LIMITED WARRANTY AND LIMITATION OF LIABILITY

Each Fluke product is warranted to be free from defects in material and workmanship under normal use and service. The warranty period is one year and begins on the date of shipment. Parts, product repairs, and services are warranted for 90 days. This warranty extends only to the original buyer or end-user customer of a Fluke authorized reseller, and does not apply to fuses, disposable batteries, or to any product which, in Fluke's opinion, has been misused, altered, neglected, contaminated, or damaged by accident or abnormal conditions of operation or handling. Fluke warrants that software will operate substantially in accordance with its functional specifications for 90 days and that it has been properly recorded on non-defective media. Fluke does not warrant that software will be error free or operate without interruption.

Fluke authorized resellers shall extend this warranty on new and unused products to end-user customers only but have no authority to extend a greater or different warranty on behalf of Fluke. Warranty support is available only if product is purchased through a Fluke authorized sales outlet or Buyer has paid the applicable international price. Fluke reserves the right to invoice Buyer for importation costs of repair/replacement parts when product purchased in one country is submitted for repair in another country.

Fluke's warranty obligation is limited, at Fluke's option, to refund of the purchase price, free of charge repair, or replacement of a defective product which is returned to a Fluke authorized service center within the warranty period.

To obtain warranty service, contact your nearest Fluke authorized service center to obtain return authorization information, then send the product to that service center, with a description of the difficulty, postage and insurance prepaid (FOB Destination). Fluke assumes no risk for damage in transit. Following warranty repair, the product will be returned to Buyer, transportation prepaid (FOB Destination). If Fluke determines that failure was caused by neglect, misuse, contamination, alteration, accident, or abnormal condition of operation or handling, including overvoltage failures caused by use outside the product's specified rating, or normal wear and tear of mechanical components, Fluke will provide an estimate of repair costs and obtain authorization before commencing the work. Following repair, the product will be returned to the Buyer transportation prepaid and the Buyer will be billed for the repair and return transportation charges (FOB Shipping Point).

THIS WARRANTY IS BUYER'S SOLE AND EXCLUSIVE REMEDY AND IS IN LIEU OF ALL OTHER WARRANTIES, EXPRESS OR IMPLIED, INCLUDING BUT NOT LIMITED TO ANY IMPLIED WARRANTY OF MERCHANTABILITY OR FITNESS FOR A PARTICULAR PURPOSE. FLUKE SHALL NOT BE LIABLE FOR ANY SPECIAL, INDIRECT, INCIDENTAL, OR CONSEQUENTIAL DAMAGES OR LOSSES, INCLUDING LOSS OF DATA, ARISING FROM ANY CAUSE OR THEORY.

Since some countries or states do not allow limitation of the term of an implied warranty, or exclusion or limitation of incidental or consequential damages, the limitations and exclusions of this warranty may not apply to every buyer. If any provision of this Warranty is held invalid or unenforceable by a court or other decision-maker of competent jurisdiction, such holding will not affect the validity or enforceability of any other provision.

Fluke Corporation
P.O. Box 9090
Everett, WA 98206-9090
U.S.A.

Fluke Europe B.V.
P.O. Box 1186
5602 BD Eindhoven
The Netherlands

11/99

To register your product online, visit register.fluke.com

Table of Contents

Title	Page
Introduction.....	1
How to Contact Fluke.....	1
Safety Information.....	1
Safety Summary.....	1
Compressed Gas.....	2
Personal Protective Equipment.....	2
Symbols Used in this Manual.....	2
Preparation.....	2
Operating Range.....	2
Connections.....	3
Test Port Insert.....	6
Operation.....	6
Maintenance and Servicing.....	7
Top Plate Removal.....	7
Screw Press Servicing.....	7
Ancillary Equipment.....	9
Angle Adapter, P5543.....	9
Pointer Remover/Punch, P5551.....	10
Dirt/Moisture Trap, P5532.....	10

List of Tables

Table	Title	Page
1.	Symbols.....	2
2.	Test Port Insert - Parts List.....	6
3.	Screw Press Assembly - Parts List.....	9

List of Figures

Figure	Title	Page
1.	Fitting Gauge Adapter.....	3
2.	Connect Assembly to Test Port.....	4
3.	Hand Tighten Only.....	4
4.	Adjust Gauge Position.....	5
5.	Tighten Gauge Adapter.....	5
6.	Hand Tighten Only.....	5
7.	Test Port Insert.....	6
8.	Screw Press Assembly.....	8
9.	Angle Adapter.....	9
10.	Pointer Remover/Punch.....	10
11.	Dirt/Moisture Trap.....	10

Introduction

This manual covers the operation and maintenance of the P5513. The Pneumatic Comparison Test Pump is used for checking pressure-measuring instruments against Master Test Gauges.

Note

The terms "Master Test Gauge" and "Gauge" in this document refer to any pressure-measuring instrument such as Transfer Standards, Digital Calibrators and Transducers.

This system is only as accurate as the Master Test Gauge used. The Master Test Gauge must be regularly calibrated on a Primary Reference Standard (such as a Deadweight Tester) to ensure accuracy is maintained.

How to Contact Fluke

To order accessories, receive operating assistance, or get the location of the nearest Fluke distributor or Service Center, call:

- Technical Support USA: 1-800-99-FLUKE (1-800-993-5853)
- Calibration/Repair USA: 1-888-99-FLUKE (1-888-993-5853)
- Canada: 1-800-36-FLUKE (1-800-363-5853)
- Europe: +31-402-675-200
- China: +86-400-810-3435
- Japan: +81-3-3434-0181
- Singapore: +65-738-5655
- Anywhere in the world: +1-425-446-5500

Or, visit Fluke's website at www.fluke.com.

To register your product, visit <http://register.fluke.com>.

To view, print, or download the latest manual supplement, visit <http://us.fluke.com/usen/support/manuals>.

Safety Information

Safety Summary

The following are general safety precautions that are not related to any specific procedures and do not appear elsewhere in this publication. These are recommended precautions that personnel must understand and apply during equipment operation and maintenance to ensure safety and health and protection of property.

Compressed Gas

Use of compressed gasses can create an environment of propelled foreign matter. Pressure system safety precautions apply to all ranges of pressure. Care must be taken during testing to ensure that all pneumatic connections are properly and tightly made prior to applying pressure. Personnel must wear eye protection to prevent injury.

Personal Protective Equipment

Wear eye protection approved for the materials and tools being used.

Warning





If the equipment is used in a+ manner not specified by the manufacturer, the protection provided by the equipment may be impaired.

Symbols Used in this Manual

In this manual, a **Warning** identifies conditions and actions that pose a hazard to the user. A **Caution** identifies conditions and actions that may damage the Pneumatic Comparison Test Pump.

Symbols used on the Pneumatic Comparison Test Pump and in this manual are explained in Table 1.

Table 1. Symbols

Symbol	Description
	AC (Alternating Current)
	Earth Ground
	Important Information: refer to manual
	Do not dispose of this product as unsorted municipal waste. Go to Fluke's website for recycling information.

Preparation

The comparison test pump should be placed on a stable workbench or similar surface.

Operating Range

The P5513 must be connected to an external gas supply through the ¼ NPT port in the rear of the instrument case. Typically, dry Nitrogen from a commercially available compressed gas cylinder is used.

The external pressure supply must be regulated to either the maximum range of the comparison test pump (3000 psi / 210 bar), or 10% above the maximum pressure required, whichever is the lower. **DO NOT OVER-PRESSURIZE THE COMPARISON TEST PUMP.**

Model	Max. Working Pressure
P5513	3000 psi / 210 bar

Connections

Fit the device under test (DUT) to the test port using the method described below:

⚠ Caution

Ensure that all devices are internally clean and free from contamination before connecting to the tester.

Particle contamination can damage the sensitive piston assemblies, valve seats and screw pump.

To avoid cross-contamination from other fluids, and protect the system from particulates, we recommend the use of a Dirt/Moisture Trap, (refer to section, Ancillary Equipment).

⚠ Warning

DO NOT use Teflon/PTFE tape on these connections, as this will prevent correct sealing. The Gauge Adapter sealing system is designed for hand-tight sealing up to 20,000 psi / 1,400 bar—wrenches or similar tools are not required — over tightening can cause damage to threads or sealing faces.

Before connection, ensure that there is an O-ring fitted to the test port.

Check that the sealing face of the device to be fitted is clean and undamaged, as scratches or dents can form leak-paths.

Note

The thread on the test port, and the lower part of the gauge adapters is LEFT-HANDED. The following procedure details the correct method for mounting devices using these adapters:

1. Screw the appropriate gauge adapter fully on to the instrument to be tested.

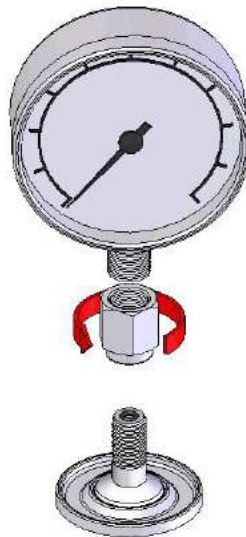

Figure 1. Fitting Gauge Adapter

gmf01.bmp

2. Screw assembly down COUNTER-CLOCKWISE on to test port.

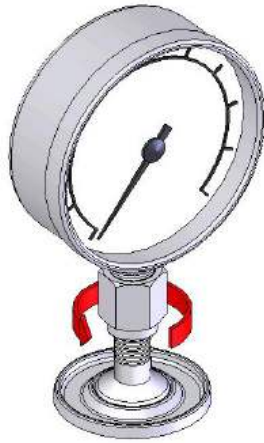

Figure 2. Connect Assembly to Test Port

gmf02.bmp



Figure 3. Hand Tighten Only

gmf03.bmp

Note

Hand-tight is sufficient; ensure that the bottom face contacts the O-ring on the test port.

3. To adjust the position to face forward, hold the gauge adapter and turn the instrument COUNTER-CLOCKWISE, so that it faces forward.

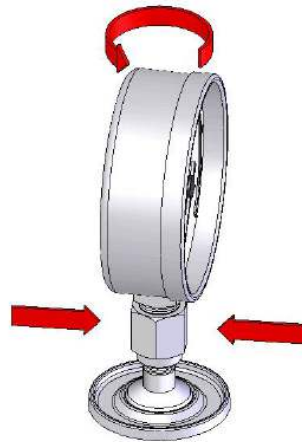

Figure 4. Adjust Gauge Position

gmf04.bmp

4. Hold the instrument steady, while turning the gauge adapter COUNTER-CLOCKWISE until it pulls down onto the O-ring.

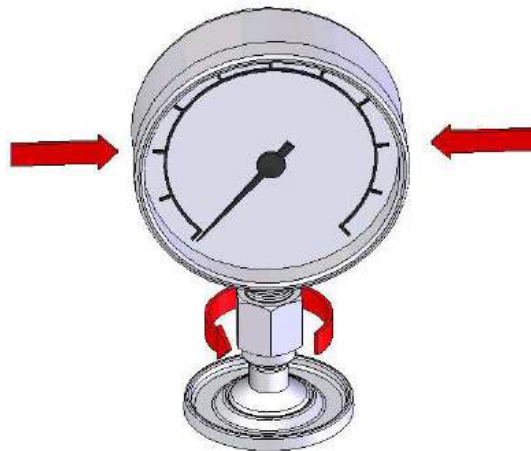

Figure 5. Tighten Gauge Adapter

gmf05.bmp



Figure 6. Hand Tighten Only

gmf06.bmp

Test Port Insert

For devices with 1/8 BSP or NPT mounting threads, the diameter of the thread is very close to the effective sealing diameter of the O-ring fitted to the test port.

This can make it difficult to achieve a good seal. When mounting these devices, use the test port insert (stored in the spare seals container) as shown in Figure 7.

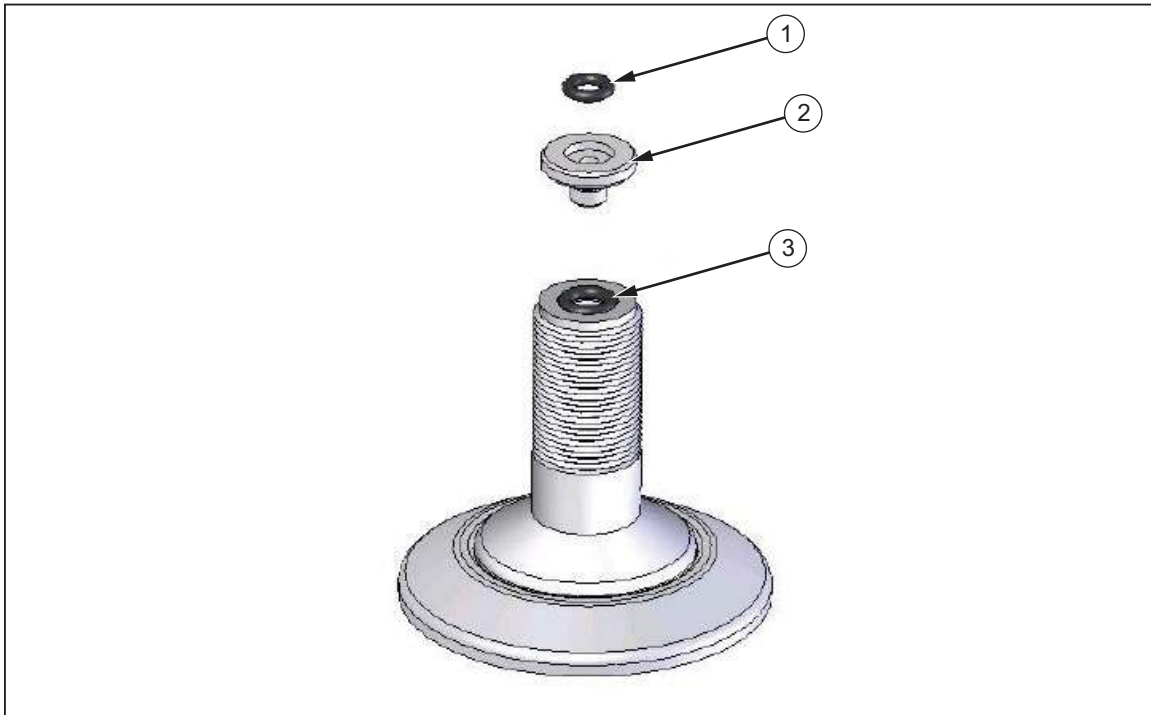

Figure 7. Test Port Insert

gmf07.eps

Table 2. Test Port Insert - Parts List

Item	Description	Part
1	O RING	3865142
2	TEST PORT INSERT	3919892
3	O RING	3883397

To calibrate panel-mounted gauges with pressure connections in the rear, use an Angle Adapter (refer to section, Ancillary Equipment).

Operation

1. To increase the system pressure, slowly open and close Increase Valve until the desired pressure is reached.
2. The Screw Press can be used for fine control of the system pressure if required, turn in (clockwise) to increase pressure, or out (counter-clockwise) to decrease.
3. Allow a few moments for the system to stabilize before taking any readings, especially after large changes in system pressure.

Note

Large, sudden changes in pressure will cause the system temperature to rise or fall, which can cause instrument readings to change as the gas in the system expands or contracts, thus increasing or decreasing the pressure.

4. For the next higher pressure point, repeat from step 1 above.
5. To reduce system pressure, slowly open and close Exhaust Valve until the desired pressure is reached. As before, the Screw Press can be used for fine adjustment of the system pressure.
6. Before taking any readings, allow a few moments for the system to stabilize as before.
7. After calibration, always vent system pressure by slowly opening the Decrease Valve.

⚠ Caution

Ensure that system is fully vented before removing DUT.

Maintenance and Servicing

⚠ Caution

If the system becomes contaminated with dirt or moisture, this will transfer to the reference gauge and, potentially, cause damage to it and the pressure system of the P5513.

If contamination is detected, the system must be disassembled and cleaned, if left to accumulate, the control needle valves and screw press may become damaged beyond repair.

Top Plate Removal

1. Turn the capstan fully in, and remove it from the instrument.
2. Remove the four screws that secure the top plate to the instrument case (located in the center of each edge).
3. Tilt the top plate upward at the rear edge, and slide the assembly backward until the screw press clears the front edge of the case.
4. Disconnect the flexible hose from the inlet valve.
5. The top plate assembly can now be removed from the instrument case.
6. Replacement is the reverse of the above procedure.

Screw Press Servicing

1. Unscrew the large union nut (just behind the inner hub) of the screw press assembly.
2. Withdraw the lead screw assembly from the barrel (4), taking care not to drop the rambler assembly (8).
3. The white, anti-extrusion ring (7) is a PTFE spiral, and can be removed by “unwinding” it from the rambler.
4. When removing the rambler seal (6), take care not to use any tool that may have a sharp edge that will scratch the surfaces of the rambler, otherwise it may leak when reassembled.
5. The replacement rambler seal can be eased over the front of the rambler, and into the groove.
6. Similarly, the new anti-extrusion ring can be “wound” into the groove in the rambler, behind the rambler seal.

7. If it is necessary to remove the barrel, the locknut (3) must be loosened approximately $\frac{1}{2}$ turn. The barrel can then be unscrewed from the test station (1).

Note

It is often easier to remove the barrel support bracket to allow greater movement, (remove the 2 screws from the upper side of the top plate).

8. Before re-fitting the barrel, ensure that the barrel seal (2) is correctly located in the counter-bore in the front of the barrel. Screw the barrel fully in to the test station, and secure with the locknut.
9. Re-align the barrel support bracket (if removed), and secure through the top plate with the 2 screws.
10. Ensure that the rambler assembly is correctly located on the end of the lead screw assembly. Carefully introduce the rambler into the open end of the barrel; making sure that it does not tilt when entering the barrel.
11. Push the lead screw assembly fully in to the barrel, ensuring that the key in the nut locates correctly in the slot in the barrel.
12. Re-tighten the barrel union nut.

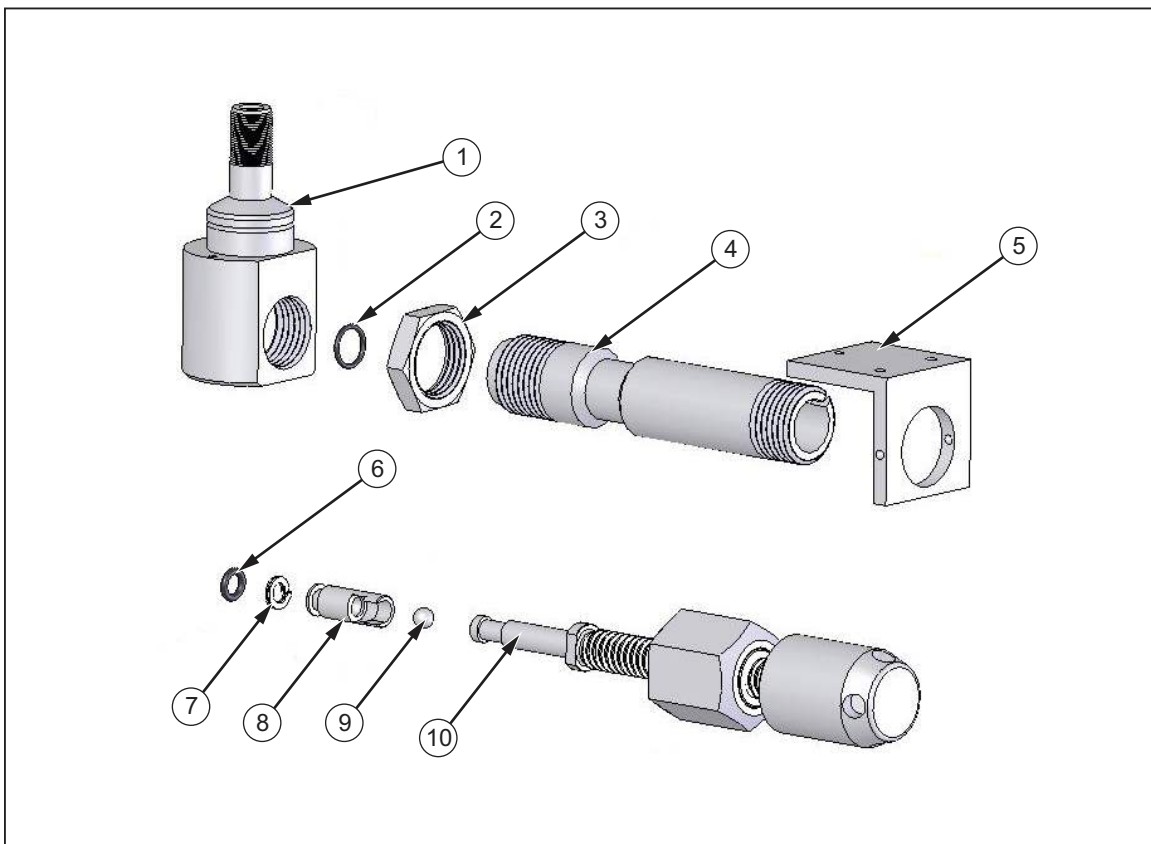

Figure 8. Screw Press Assembly

gmf08.eps

Table 3. Screw Press Assembly - Parts List

Item	Description	Part
1	TEST STATION	3921414
2	O RING	3864922
3	LOCKNUT	3921438
4	BARREL	3921450
5	SUPPORT BRACKET	3921492
6	O RING	3867566
7	ANTI-EXTRUSION RING	3919118
8	RAMBLER	3919129
9	BALL	3917855
10	LEAD SCREW ASSY	3885994

Ancillary Equipment

Angle Adapter, P5543

To calibrate gauges with the pressure connection on the rear (e.g. panel-mount gauges) in their correct position, an angle adapter should be used. The angle adapter fits directly onto the test station, converting it through 90 degrees, allowing the standard adapters to be used.



Figure 9. Angle Adapter

gmf09.bmp

Pointer Remover/Punch, P5551

To remove and refit the pointer of a pressure gauge, use this tool. This tool has a spring-loaded plunger to quickly and consistently refit the pointer.



Figure 10. Pointer Remover/Punch

gmf10.bmp

Dirt/Moisture Trap, P5532

Dirt/Moisture Traps provide an effective barrier against the transfer of moisture and dirt from an instrument under test to the clean pneumatic system of the comparison test pump and the master test gauge connected to it. Unexpected particle contamination or fluid inside the device under test will be prevented from entering the test system, avoiding downtime for maintenance and repair.



Figure 11. Dirt/Moisture Trap

gmf11.bmp