

721

Pressure Calibrator

Calibration Manual

January 2014

© 2014 Fluke Corporation. All rights reserved. Specifications are subject to change without notice.
All product names are trademarks of their respective companies.

LIMITED WARRANTY AND LIMITATION OF LIABILITY

Each Fluke product is warranted to be free from defects in material and workmanship under normal use and service. The warranty period is three years and begins on the date of shipment. Parts, product repairs, and services are warranted for 90 days. This warranty extends only to the original buyer or end-user customer of a Fluke authorized reseller, and does not apply to fuses, disposable batteries, or to any product which, in Fluke's opinion, has been misused, altered, neglected, contaminated, or damaged by accident or abnormal conditions of operation or handling. Fluke warrants that software will operate substantially in accordance with its functional specifications for 90 days and that it has been properly recorded on non-defective media. Fluke does not warrant that software will be error free or operate without interruption.

Fluke authorized resellers shall extend this warranty on new and unused products to end-user customers only but have no authority to extend a greater or different warranty on behalf of Fluke. Warranty support is available only if product is purchased through a Fluke authorized sales outlet or Buyer has paid the applicable international price. Fluke reserves the right to invoice Buyer for importation costs of repair/replacement parts when product purchased in one country is submitted for repair in another country.

Fluke's warranty obligation is limited, at Fluke's option, to refund of the purchase price, free of charge repair, or replacement of a defective product which is returned to a Fluke authorized service center within the warranty period.

To obtain warranty service, contact your nearest Fluke authorized service center to obtain return authorization information, then send the product to that service center, with a description of the difficulty, postage and insurance prepaid (FOB Destination). Fluke assumes no risk for damage in transit. Following warranty repair, the product will be returned to Buyer, transportation prepaid (FOB Destination). If Fluke determines that failure was caused by neglect, misuse, contamination, alteration, accident, or abnormal condition of operation or handling, including overvoltage failures caused by use outside the product's specified rating, or normal wear and tear of mechanical components, Fluke will provide an estimate of repair costs and obtain authorization before commencing the work. Following repair, the product will be returned to the Buyer transportation prepaid and the Buyer will be billed for the repair and return transportation charges (FOB Shipping Point).

THIS WARRANTY IS BUYER'S SOLE AND EXCLUSIVE REMEDY AND IS IN LIEU OF ALL OTHER WARRANTIES, EXPRESS OR IMPLIED, INCLUDING BUT NOT LIMITED TO ANY IMPLIED WARRANTY OF MERCHANTABILITY OR FITNESS FOR A PARTICULAR PURPOSE. FLUKE SHALL NOT BE LIABLE FOR ANY SPECIAL, INDIRECT, INCIDENTAL OR CONSEQUENTIAL DAMAGES OR LOSSES, INCLUDING LOSS OF DATA, ARISING FROM ANY CAUSE OR THEORY.

Since some countries or states do not allow limitation of the term of an implied warranty, or exclusion or limitation of incidental or consequential damages, the limitations and exclusions of this warranty may not apply to every buyer. If any provision of this Warranty is held invalid or unenforceable by a court or other decision-maker of competent jurisdiction, such holding will not affect the validity or enforceability of any other provision.

Fluke Corporation
P.O. Box 9090
Everett, WA 98206-9090
U.S.A.

Fluke Europe B.V.
P.O. Box 1186
5602 BD Eindhoven
The Netherlands

Table of Contents

Title	Page
Introduction.....	1
Contact Fluke	1
Safety Information	2
Symbols.....	3
Specifications	4
Environmental.....	4
Electrical and Temperature Measurement (1 year)	4
Physical	4
Required Equipment.....	6
Performance Verification Tests	6
Pressure Verification	7
DC Voltage Measure Verification	9
DC Current Measure Verification.....	10
RTD Measure Verification	10
720RTD Probe Verification.....	11
mA Loop Performance Check	11
Calibration Adjustment	12
Initiate Communication	12
Adjust Voltage Input	13
Adjust mA Input	13
Adjust RTD	14
Adjust Pressure	15
Maintenance	16
Replace the Batteries	16
Clean the Product.....	18
User-Replaceable Parts	18
Accessories	19

List of Tables

Table	Title	Page
1.	Symbols.....	3
2.	Required Equipment for Verification and Calibration	6
3.	Pressure Verification Tests	7
4.	DC Voltage Measure Verification Tests	9
5.	DC Current Measure Verification Tests.....	10
6.	RTD Measure Verification Tests	10
7.	720RTD Probe Verification Tests.....	11
8.	User-Replaceable Parts and Accessories	18
9.	Accessories	19

List of Figures

Figure	Title	Page
1.	Battery Replacement.....	17
2.	User-Replaceable Parts	20

Introduction

The 721 Pressure Calibrator (the Product) is a simple to use and versatile pressure calibrator. The two internal pressure sensors are configured with different pressure measurement ranges. One range for lower pressure (P1) and one range for higher pressure (P2). The Product features inputs for mA, switch contacts, and an RTD probe. An external pressure module option gives a wider range of pressure calibration options that include absolute and differential pressure measurement.

Contact Fluke

To contact Fluke, call one of the following telephone numbers:

- Technical Support USA: 1-800-44-FLUKE (1-800-443-5853)
- Calibration/Repair USA: 1-888-99-FLUKE (1-888-993-5853)
- Canada: 1-800-36-FLUKE (1-800-363-5853)
- Europe: +31 402-675-200
- Japan: +81-3-6714-3114
- Singapore: +65-6799-5566
- Anywhere in the world: +1-425-446-5500

Or, visit Fluke's website at www.fluke.com.

To register your product, visit <http://register.fluke.com>.

To download manuals, or to view, print, or download the latest manual supplement, visit <http://us.fluke.com/usen/support/manuals>.

Safety Information

A **Warning** identifies conditions and procedures that are dangerous to the user. A **Caution** identifies conditions and procedures that can cause damage to the Product or the equipment under test.

Warning

To prevent possible electrical shock, fire, or personal injury:











- Only assemble and operate high-pressure systems if you know the correct safety procedures. High-pressure liquids and gases are hazardous and the energy from them can be released without warning.
- Read all safety information before you use the Product.
- Carefully read all instructions.
- Do not use the Product around explosive gas or vapor.
- Use the correct terminals, function, and range for measurements.
- Do not apply more than the rated voltage, between the terminals or between each terminal and earth ground.
- Do not touch voltages >30 V ac rms, 42 V ac peak, or 60 V dc.
- Remove all probes, test leads, and accessories before the battery door is opened.
- Do not exceed the Measurement Category (CAT) rating of the lowest rated individual component of a Product, probe, or accessory.
- Disable the Product if it is damaged.
- Do not use the Product if it is damaged.
- Remove the input signals before you clean the Product.
- Use only specified replacement parts.
- Have an approved technician repair the Product.
- Use the Product only as specified, or the protection supplied by the Product can be compromised.
- Pressure sensors can be damaged and/or personnel injury can occur due to improper application of pressure. Vacuum should not be applied to any gauge pressure sensor. The Product display shows “OL” when an inappropriate pressure is applied. If “OL” is shown on any pressure display, the pressure should be reduced or vented immediately to prevent Product damage or possible personnel injury. “OL” is shown when the pressure exceeds 110 % of the nominal range of the sensor or when a vacuum in excess of 2 PSI is applied on gauge range sensors.

- Push the ZERO button to zero the pressure sensor when vented to atmospheric pressure.
- Remove the batteries if the Product is not used for an extended period of time, or if stored in temperatures that exceed the battery manufacturer's specifications. If the batteries are not removed, battery leakage can damage the Product.
- Replace the batteries when the low battery indicator shows to prevent incorrect measurements.
- Be sure that the battery polarity is correct to prevent battery leakage.
- Repair the Product before use if the battery leaks.
- The battery door must be closed and locked before you operate the Product.
- Use only specified replacement parts.

Symbols

Symbols used on the Product or in this manual are shown in Table 1.

Table 1. Symbols

Symbol	Description	Symbol	Description
	Risk of Danger. Important information. See Manual.		Conforms to relevant North American Safety Standards.
	Hazardous voltage. Risk of electric shock.		Double Insulated
	Conforms to European Union directives.		Conforms to relevant Australian EMC standards.
	Inspected and licensed by TÜV Product Services.		Battery
	This product complies with the WEEE Directive (2002/96/EC) marking requirements. The affixed label indicates that you must not discard this electrical/electronic product in domestic household waste. Product Category: With reference to the equipment types in the WEEE Directive Annex I, this product is classed as category 9 "Monitoring and Control Instrumentation" product. Do not dispose of this product as unsorted municipal waste. Go to Fluke's website for recycling information.		Conforms to relevant South Korean EMC Standards.

1-year Specifications		Low Pressure Sensor			High Pressure Sensor		
Model	Calibrator Description	Range Sensor 1	Resolution Sensor 1	Accuracy Sensor 1	Range Sensor 2	Resolution Sensor 2	Accuracy Sensor 2
721-1601	16 PSIG, 100 PSIG	-14 psi + 16 psi -0.97 bar to 1.1 bar	0.001 psi, 0.0001 bar	0.025 % of full scale	-12 psi to +100 psi -0.83 bar to 6.9 bar	0.001 psi 0.0001 bar	0.025 % of full scale
721-1603	16 PSIG, 300 PSIG				-12 psi to +300 psi -0.83 bar to 20 bar	0.01 psi 0.001 bar	
721-1605	16 PSIG, 500 PSIG				-12 psi to +500 psi -0.83 bar to 34.5 bar	0.01 psi 0.001 bar	
721-1610	16 PSIG, 1000 PSIG				0 psi to +1000 psi 0.00 bar to 69 bar	0.01 psi 0.001 bar	
721-1615	16 PSIG, 1500 PSIG				0 psi to +1500 psi 0.00 bar to 103.4 bar	0.1 psi 0.01 bar	
721-1630	16 PSIG, 3000 PSIG				0 psi to +3000 psi 0.00 bar to 200 bar	0.1 psi 0.01 bar	
721-1650	16 PSIG, 5000 PSIG				0 psi to +5000 psi 0.00 bar to 345 bar	0.1 psi 0.01 bar	
721-3601	36 PSIG, 100 PSIG	-14 psi + 36 psi -0.97 bar to 2.48 bar	0.001 psi, 0.0001 bar	0.025 % of full scale	-12 psi to +100 psi -0.83 bar to 6.9 bar	0.001 psi 0.0001 bar	0.025 % of full scale
721-3603	36 PSIG, 300 PSIG				-12 psi to +300 psi -0.83 bar to 20 bar	0.01 psi 0.001 bar	
721-3605	36 PSIG, 500 PSIG				-12 psi to +500 psi -0.83 bar to 34.5 bar	0.01 psi 0.001 bar	
721-3610	36 PSIG, 1000 PSIG				0 psi to +1000 psi 0.00 bar to 69 bar	0.01 psi 0.001 bar	
721-3615	36 PSIG, 1500 PSIG				0 psi to +1500 psi 0.00 bar to 103.4 bar	0.1 psi 0.01 bar	
721-3630	36 PSIG, 3000 PSIG				0 psi to +3000 psi 0.00 bar to 200 bar	0.1 psi 0.01 bar	
721-3650	36 PSIG, 5000 PSIG				0 psi to +5000 psi 0.00 bar to 345 bar	0.1 psi 0.01 bar	

Electromagnetic Environment..... IEC 61326-1: Portable

Electromagnetic Compatibility..... Applies to use in Korea only. Class A Equipment (Industrial Broadcasting & Communication Equipment) ^[1]

[1] This product meets requirements for industrial (Class A) electromagnetic wave equipment and the seller or user should take notice of it. This equipment is intended for use in business environments and is not to be used in homes.

Required Equipment

The equipment listed in Table 2 is necessary to do the performance verification tests and calibration adjustment.

Table 2. Required Equipment for Verification and Calibration

Equipment	Minimum Specifications	Recommended Model
Low-thermal EMF banana to banana leads	-	Pomona 2948-36-2 (red) and 2948-36-0 (black)
RTD adapter	-	Fluke 720URTDA
Calibrator/Resistance Standard	0 V to 30 V Accuracy: 0.006 % rdg \pm 0.5 mV 0 mA to 24 mA Accuracy: 0.006 % rdg \pm 0.25 μ A -40 °C to 150 °C RTD 0.033 °C	Fluke Calibration 7526A
Pressure Controller/Calibrator	-14 PSI to 1000 PSI 0.005 %	Ruska 7250xi
Piston Gauge	3000 PSI to 5000 PSI 0.005 %	Fluke Calibration PG7302 or PG7202
Metrology Well	-30 °C to 140 °C 0.06 °C	Fluke Calibration 9170

Performance Verification Tests

Warning

To prevent possible electrical shock, fire, or personal injury, do not perform the performance test or verification test procedures unless the Product is fully assembled.

The performance tests verify the complete operation of the Product and measure the accuracy of each function against Product specifications. If the Product fails a part of the test, calibration adjustment or repair is necessary. See “Calibration Adjustment Procedure”.

The performance verification tests check the accuracy of each Product function against its specifications. If the Product fails any of these tests, calibration adjustment or repair is necessary.

Pressure Verification

To do the pressure verification test:

1. Carefully attach the pressure fitting of the Pressure Controller/Calibrator or Piston Gauge (called pressure source for the remainder of this procedure) to the first pressure port of the Product.

Note

Use plenty of TEFLON tape when attaching pressure fitting.

The display should read 0.00 PSI with the deadweight tester opened up to ambient air. If not, push  until both displays read 0.00 PSI.

2. Set up the deadweight tester for the sequence of PSI inputs from Table 3 to be injected into the pressure port of the Product.
3. Ensure the pressure has stabilized at each input before you verify the display reading.
4. Carefully vent all pressure and disconnect the first pressure port.
5. Connect and test the second pressure port.
6. Set up the deadweight tester for the sequence of PSI inputs from Table 3 to be injected into the pressure port of the Product.
7. Ensure the pressure has stabilized at each input before you verify the display reading.
8. Set up the deadweight tester for the sequence of PSI inputs from Table 3 to be injected into the pressure port of the Product.
9. Ensure the pressure has stabilized at each input before you verify the display reading.

Table 3. Pressure Verification Tests

16 PSI			36 PSI		
Input Pressure	Lower Limit	Upper Limit	Input Pressure	Lower Limit	Upper Limit
16.000	15.996	16.004	36.000	35.991	36.009
13.000	12.996	13.004	29.000	28.991	29.009
10.000	9.996	10.004	22.000	21.991	22.009
6.000	5.996	6.004	14.000	13.991	14.009
3.000	2.996	3.004	7.000	6.991	7.009
0.000	-0.004	0.004	0.000	-0.009	0.009
-5.000	-5.004	-4.996	-5.000	-5.009	-4.991
-10.000	-10.004	-9.996	-10.000	-10.009	-9.991
-13.750	-13.754	-13.746	-13.750	-13.759	-13.741

Table 3. Pressure Verification Tests (cont.)

100 PSI		
Input Pressure	Lower Limit	Upper Limit
100.00	99.975	100.025
80.00	79.975	80.025
60.00	59.975	60.025
40.00	39.975	40.025
20.00	19.975	20.025
0.00	-0.025	0.025
-6.00	-6.025	-5.975
-12.00	-12.025	-11.975

300 PSI		
Input Pressure	Lower Limit	Upper Limit
300.00	299.92	300.08
240.00	239.92	240.08
180.00	179.92	180.08
120.00	119.92	120.08
60.00	59.92	60.08
0.00	-0.08	0.08
-6.00	-6.08	-5.92
-12.00	-12.08	-11.92

500 PSI		
Input Pressure	Lower Limit	Upper Limit
500.00	499.87	500.13
400.00	399.87	400.13
300.00	299.87	300.13
200.00	199.87	200.13
100.00	99.87	100.13
0.00	-0.13	0.13
-6.00	-6.13	-5.87
-12.00	-12.13	-11.87

1000 PSI		
Input Pressure	Lower Limit	Upper Limit
1000.0	999.75	1000.25
800.0	799.75	800.25
600.0	599.75	600.25
400.0	399.75	400.25
200.0	199.75	200.25
0.0	-0.25	0.25

1500 PSI		
Input Pressure	Lower Limit	Upper Limit
1500.0	1499.6	1500.4
1200.0	1199.6	1200.4
900.0	899.6	900.4
600.0	599.6	600.4
300.0	299.6	300.4
0.0	-0.4	0.4

3000 PSI		
Input Pressure	Lower Limit	Upper Limit
3000.0	2999.2	3000.8
2400.0	2399.2	2400.8
1800.0	1799.2	1800.8
1200.0	1199.2	1200.8
600.0	599.2	600.8
0.0	-0.8	0.8

Table 3. Pressure Verification Tests (cont.)

5000 PSI		
Input Pressure	Lower Limit	Upper Limit
5000.0	4998.2	5001.8
4000.0	3998.2	4001.8
3000.0	2998.2	3001.8
2000.0	1998.2	2001.8
1000.0	998.2	1001.8
0.0	-1.8	1.8

10. Carefully vent all pressure and disconnect the second pressure port.

DC Voltage Measure Verification

To do the dc voltage measure verification test:

1. Push **F2** repeatedly until VOLTS is shown on the third row of the Product display.
2. Connect the Product red banana jack (V mA) to the Calibrator HI VOLTS output.
3. Connect the Product black banana jack (COM) to the Calibrator LO VOLTS output.
4. Set the Calibrator for the voltage setting in Table 4, and verify the display reading on the Product.

Table 4. DC Voltage Measure Verification Tests

Applied Voltage from 7526A	Lower limit	Upper Limit
0.000 V	-0.002 V	0.002 V
15.000 V	14.996 V	15.004 V
30.000 V	29.994 V	30.007 V

5. Set the Calibrator to Standby.

DC Current Measure Verification

To do the dc current measure verification test:

1. Push **F2** repeatedly until mA is shown in the third row of the Product display.
2. Connect the Product red banana jack (V mA) to the Calibrator HI mA output.
3. Connect the Product black banana jack (COM) to the Calibrator LO mA output.
4. Set the Calibrator for the current setting in Table 5, and verify the display reading on the Product.

Table 5. DC Current Measure Verification Tests

Applied Current from the Calibrator	Lower limit	Upper Limit
4.000 mA	3.997 mA	4.003 mA
12.000 mA	11.996 mA	12.004 mA
24.000 mA	23.994 mA	24.006 mA

5. Set the Calibrator to Standby.

RTD Measure Verification

1. Push **F2** repeatedly until RTD is shown in the third row of the Product display.
2. Connect the RTD Adapter to the Product.
3. Connect the RTD Adapter Current HI to the Calibrator HI RTD output.
4. Connect the RTD Adapter Sense HI to the Calibrator HI RTD output.
5. Connect the RTD Adapter Current LO to the Calibrator LO RTD output.
6. Connect the RTD Adapter Sense LO to the Calibrator LO RTD output.
7. Set the Calibrator to the 400 Ω range, output the resistance setting in Table 6, and verify that the display reading on the Product is within the limits.
8. Set Calibrator to standby.

Table 6. RTD Measure Verification Tests

Applied Current from the Calibrator	Lower limit	Upper Limit
84.270 Ω	-40.10 $^{\circ}\text{C}$	-39.90 $^{\circ}\text{C}$
100.000 Ω	-0.10 $^{\circ}\text{C}$	0.10 $^{\circ}\text{C}$
157.325 Ω	149.90 $^{\circ}\text{C}$	150.10 $^{\circ}\text{C}$

720RTD Probe Verification

This is an optional test for a Product that is paired with a 720RTD. To do this test:

1. Push **F2** repeatedly until RTD is shown in the third row of the Product display.
2. Plug the 720RTD probe into the Product.
3. Insert the probe into the Metrology Well.
4. Set the Metrology Well to the temperatures in Table 7, after the Well stabilizes, verify that the display readings are within tolerance.

Table 7. 720RTD Probe Verification Tests

Applied Temperature	Lower Limit	Upper Limit
-30.00 °C	-30.25 °C	-29.75 °C
0.00 °C	-0.25 °C	0.25 °C
70.00 °C	69.75 °C	70.25 °C
130.00 °C	129.75 °C	130.25 °C

5. Set the Metrology Well to Standby.

mA Loop Performance Check

The Loop Voltage function does not have traceable specifications, this is a functional check.

1. Push **F2** repeatedly until mA Loop is shown in the third row of the Product display.
2. Connect the Product red banana jack (V mA) the Calibrator HI input.
3. Connect the Product black banana jack (COM) to the Calibrator LO input
4. Set the Calibrator to the 100 V range, the voltage measured should be between 22 V and 30 V.

Calibration Adjustment

The Product has an electronic calibration process. There are no mechanical adjustments and the calibration is done with the case closed. A serial communications port is used for the calibration process to send commands and receive readings. The normal RS232 interface is used. Calibration can be done with a terminal program or an automated-calibration program can be written with programs like MetCal. In this manual, only the serial terminal mode is described.

Table 2 lists the required equipment.

Initiate Communication

Terminal communications can be set up with terminal communication software on a PC such as Hyperterminal or Ucon. Connect the RS232 cable to the 5-pin Lemo on the side of the Product. Connect the other end of the cable to the terminal/PC serial port.

The terminal settings need to be set as follows:

- Bits per second: 9600
- Data bits: 8
- Parity: None
- Stop bits: 1
- Flow control: none
- Local echo: on

First, enable the full-command set by sending HC_GASUI_OFF . Check that it turned off by sending HC_GASUI?, The Product should reply OFF. All calibration commands are done on the functions selected on the lower display. Use the following command sequence to turn off all but the lower display:

DISPLAY UPPER, OFF DISPLAY MIDDLE, OFF DISPLAY LOWER, ON

As long as the Product has been at a stable temperature, within the range of 20 °C to 26 °C for an hour or longer, the Product only needs 5 minutes to warm up. If temperature conditions were previously below 10 °C or higher than 40 °C, then the unit must be allowed to stabilize for a minimum of 3 hours prior to calibration.

Adjust Voltage Input

To adjust the voltage input:

1. Use the test lead set to attach the voltage output of the Calibrator to the input of the Product.
2. Send this command to put the Product into Voltage mode:
FUNC LOWER,DCV
3. Use the Calibrator to input 0 V.
4. When the reading is stable, send this command:
CAL_POINT[0] [0]
5. Use the Calibrator to input 30 V.
6. When the reading is stable, send this command:
CAL_POINT[0][1]
7. The voltage range is now calibrated.

Adjust mA Input

To adjust the mA input:

1. Use the test lead set to attach the voltage output of the Calibrator to the input of the Product.
2. Send this command to put the Product in Current mode:
FUNC LOWER,DCI
3. Use the Calibrator to input 0 mA.
4. When the reading is stable, send this command:
CAL_POINT[0][0]
5. Use the Calibrator to input 24 mA.
6. When the reading is stable, send this command:
CAL_POINT[0][1]
7. The voltage range is now calibrated. Use the Calibrator to verify calibration.

Adjust RTD

Before the adjustment, make these connections:

1. Plug the RTD Adapter into the Product.
2. Connect the high side of the current output (ohms measure) jacks of the RTD Adapter to the high side of the current input of the Resistance Standard.
3. Connect the low side of the current output (ohms measure) of the RTD Adapter to the low side of the current input of the Resistance Standard.
4. Connect the high side of the sense jacks of the RTD Adapter to the high side of the sense output of the Resistance Standard.
5. Connect the low side of the sense jacks of the RTD Adapter sense input to the low side of the sense output of the Resistance Standard.

To make the adjustment:

1. After you have made your connections, send this command to put the unit in RTD mode:

```
FUNC LOWER,RTD
```

2. Use the Resistance Standard to input 90 Ω .
3. When the reading is stable send this command:

```
CAL_POINT[0][0]
```
4. Use the Resistance Standard to input 140 Ω .
5. When the reading is stable, send this command:

```
CAL_POINT[0][1]
```
6. The RTD range is now calibrated. Use the Resistance Standard to verify calibration.

Adjust Pressure

The Product uses a 1/8 inch NPT female connection in the pressure input port. Various adapters may be necessary to connect to the pressure standard. Always make sure the hose, tubing, fittings, etc., have a rated working pressure at or above the pressure of the Product. It is important that there are no leaks. Use Teflon tape where appropriate.

To adjust the pressure:

1. Send this command to put the Product into pressure mode:
FUNC LOWER,{port} where port is either P1 or P2.
2. Send the OFFSET_ADJ? command.
3. Note the value returned.
4. Use the Pressure Standard to input a value equal or close to the noted value.
5. When the pressure is stable, send the OFFSET_ADJ n command where n is the entered pressure.
6. Send the GAIN_ADJ? command.
7. Note the value returned.
8. Use the Pressure Standard to input a value equal or close to the noted value.
9. When the pressure is stable, send the command GAIN_ADJ n where n is the applied pressure.

The pressure is now adjusted. Restore normal operation by turning the other displays back on. Send DISPLAY UPPER, ON then DISPLAY MIDDLE, ON. Check the unit display. There should be three bars across the display, the upper three show reading, the bottom showing the F key functions. Then, send HC_GASUI_ON. Verify that it is on by sending HC_GASUI?. The unit should reply ON.

Maintenance

Replace the Batteries

If the batteries discharge too far, the Product automatically shuts down to prevent battery leakage.

Note

Use only AA size alkaline batteries.

 **Warning**

To prevent possible electrical shock, fire, or personal injury:

- **Remove the batteries if the Product is not used for an extended period of time, or if stored in temperatures above 50 °C. If the batteries are not removed, battery leakage can damage the Product.**
- **Replace the batteries when the low battery indicator shows to prevent incorrect measurements.**
- **Be sure that the battery polarity is correct to prevent battery leakage.**
- **Repair the Product before use if the battery leaks.**
- **The battery door must be closed and locked before you operate the Product.**

To change the batteries, see Figure 1:

1. Turn off the Product.
2. Turn the Product so that the display is down.
3. With a flat-head screwdriver, remove the battery door screw.
4. Replace the four AA batteries with new batteries. Make sure that the polarity on the batteries is correct.
5. Replace the battery door.
6. Tighten the battery door screw.

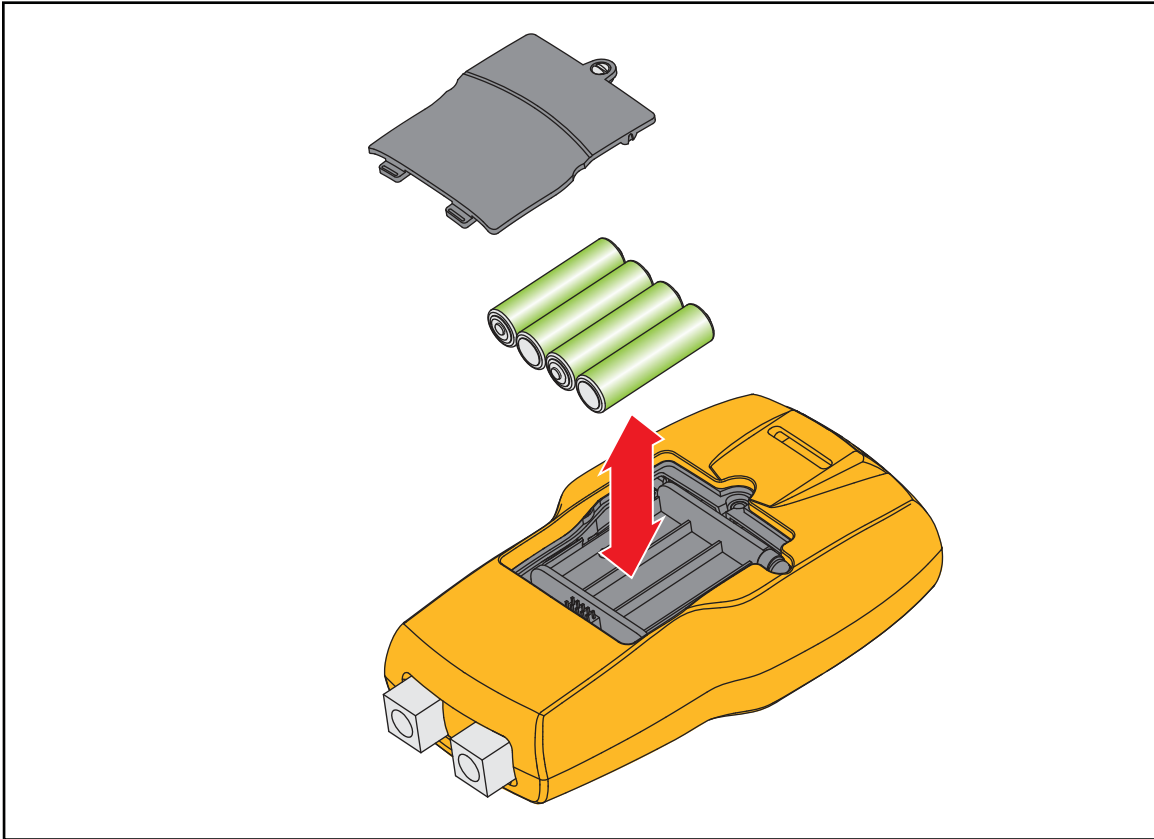

Figure 1. Battery Replacement

hmq061.eps

Clean the Product

⚠ Caution

To avoid damaging the plastic lens and case, do not use solvents or abrasive cleansers.

Clean the Product with a soft cloth dampened with water or water and mild soap.

User-Replaceable Parts

⚠⚠ Warning

To prevent possible electrical shock, fire, or personal injury, use only specified replacement parts.

User-replaceable parts are listed in Table 8 and shown in Figure 2. For more information about these items, contact a Fluke representative. See the “Contact Fluke” section of this manual.

Table 8. User-Replaceable Parts and Accessories

Item Number	Description	Qty	Part Number
①	Case Top Assembly For 721	1	4409796
②	Fluke-721 Lens, 721	1	4364743
③	Screw, 5-20k.312, Ph, Threaded	4	494641
④	Fluke-7xx, Display Module	1	4404450
⑤	Fluke-721 Keypad	1	4364568
⑥	Conn, Panel Mount, Circ,	1	942714
⑦	Insulator, Input Receptacle, Red	1	664257
⑧	Insulator, Input Receptacle, Black	1	664265
⑨	Battery, AA, Alkaline	4	376756
⑩	Fluke-721 Beltline Gasket, Black	1	4364546
⑪	Case Bottom Assembly For 721	1	4409801
⑫	Fluke-721-2003,Holster, Yellow	1	4364505
⑬	Fluke-721 Battery Door, Gray 8	1	4364522
⑭	Screw, 4x5/16, Pan Head	5	642931
⑮	Fluke-721 Foot, Black	2	4364579
Not Shown	Decal, Manifold Range,100 Psi,	1	4110705
Not Shown	Decal, Manifold Range,300 Psi	1	4110710
Not Shown	Decal, Manifold Range,500 Psi	1	4110722
Not Shown	Decal, Manifold Range,1000 Psi	1	4110731
Not Shown	Decal, Manifold Range,3000 Psi	1	4110746

Table 9. User-Replaceable Parts and Accessories (cont.)

Item Number	Description	Qty	Part Number
Not Shown	Decal, Manifold Range,5000 Psi	1	4110754
Not Shown	Decal, Manifold Range 16psi 1.1bar	1	4374274
Not Shown	Decal, Manifold Range 36psi 2.5bar	1	4374288
Not Shown	Decal, Manifold Range 1500psi 100bar	1	4374301
Not Shown	Fluke-721,Decal, Rear, Serial Number Plate	1	4364755
Not Shown	Tie, Cable, 4"	1	172080
See www.fluke.com for more information about the test leads and alligator clips available for your region.			

Accessories

Table 9 is a list of available accessories for the Product.

Table 10. Accessories

Part Number	Description
4382695	Fluke-720URTD, Universal RTD Adapter, For 719Pro And 721
4380630	721 Carrying Case
See www.fluke.com for more information about the test leads and alligator clips available for your region.	

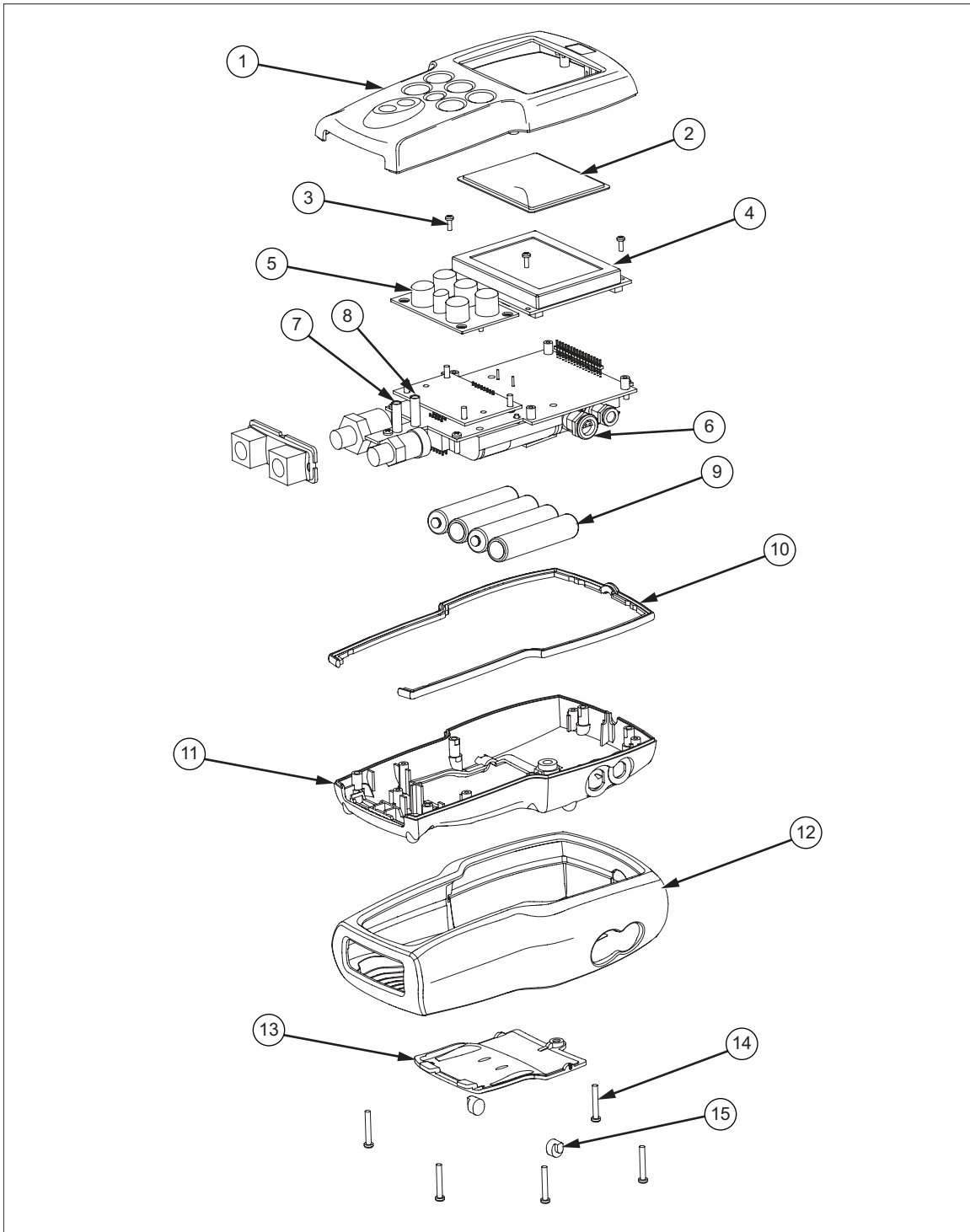

Figure 2. User-Replaceable Parts

hmq101.eps