

700G Series

Pressure Gauge

Calibration Manual

LIMITED WARRANTY AND LIMITATION OF LIABILITY

Each Fluke product is warranted to be free from defects in material and workmanship under normal use and service. The warranty period is three years and begins on the date of shipment. Parts, product repairs, and services are warranted for 90 days. This warranty extends only to the original buyer or end-user customer of a Fluke authorized reseller, and does not apply to fuses, disposable batteries, or to any product which, in Fluke's opinion, has been misused, altered, neglected, contaminated, or damaged by accident or abnormal conditions of operation or handling. Fluke warrants that software will operate substantially in accordance with its functional specifications for 90 days and that it has been properly recorded on non-defective media. Fluke does not warrant that software will be error free or operate without interruption.

Fluke authorized resellers shall extend this warranty on new and unused products to end-user customers only but have no authority to extend a greater or different warranty on behalf of Fluke. Warranty support is available only if product is purchased through a Fluke authorized sales outlet or Buyer has paid the applicable international price. Fluke reserves the right to invoice Buyer for importation costs of repair/replacement parts when product purchased in one country is submitted for repair in another country.

Fluke's warranty obligation is limited, at Fluke's option, to refund of the purchase price, free of charge repair, or replacement of a defective product which is returned to a Fluke authorized service center within the warranty period.

To obtain warranty service, contact your nearest Fluke authorized service center to obtain return authorization information, then send the product to that service center, with a description of the difficulty, postage and insurance prepaid (FOB Destination). Fluke assumes no risk for damage in transit. Following warranty repair, the product will be returned to Buyer, transportation prepaid (FOB Destination). If Fluke determines that failure was caused by neglect, misuse, contamination, alteration, accident, or abnormal condition of operation or handling, including overvoltage failures caused by use outside the product's specified rating, or normal wear and tear of mechanical components, Fluke will provide an estimate of repair costs and obtain authorization before commencing the work. Following repair, the product will be returned to the Buyer transportation prepaid and the Buyer will be billed for the repair and return transportation charges (FOB Shipping Point).

THIS WARRANTY IS BUYER'S SOLE AND EXCLUSIVE REMEDY AND IS IN LIEU OF ALL OTHER WARRANTIES, EXPRESS OR IMPLIED, INCLUDING BUT NOT LIMITED TO ANY IMPLIED WARRANTY OF MERCHANTABILITY OR FITNESS FOR A PARTICULAR PURPOSE. FLUKE SHALL NOT BE LIABLE FOR ANY SPECIAL, INDIRECT, INCIDENTAL OR CONSEQUENTIAL DAMAGES OR LOSSES, INCLUDING LOSS OF DATA, ARISING FROM ANY CAUSE OR THEORY.

Since some countries or states do not allow limitation of the term of an implied warranty, or exclusion or limitation of incidental or consequential damages, the limitations and exclusions of this warranty may not apply to every buyer. If any provision of this Warranty is held invalid or unenforceable by a court or other decision-maker of competent jurisdiction, such holding will not affect the validity or enforceability of any other provision.

Fluke Corporation
P.O. Box 9090
Everett, WA 98206-9090
U.S.A.

Fluke Europe B.V.
P.O. Box 1186
5602 BD Eindhoven
The Netherlands

Table of Contents

Title	Page
Introduction.....	1
How to Contact Fluke	1
Safety Information	2
Hazard Location Information/Approvals.....	2
Special Conditions for Safe Use.....	3
Symbols	3
Specifications.....	4
Available Input Ranges	4
Accuracy 700G Ranges	4
Accuracy 700RG Ranges	4
Media Compatibility.....	4
Environmental	4
Mechanical Specifications.....	5
Ranges and Resolution	6
Maintenance.....	7
How to Clean the Product.....	7
How to Change the Batteries	8
Performance Verification Tests	9
Required Equipment	9
How to Verify Pressure	9
Calibration Adjustment.....	16
Test Equipment.....	16
Connections	16
Enter 2-Point Adjust Mode.....	16
Full Adjust.....	17
Procedure Example.....	17
Serial Interface	20
List of Commands	21
Parameter Units	22
Error Codes.....	23
Replacement Parts and Accessories.....	24

List of Tables

Table	Title	Page
1.	Symbols.....	3
2.	Equipment Required for Verification.....	9
3.	Verification Points (In psi).....	10
4.	Calibration Points.....	19
5.	Commands.....	21
6.	Measurement Units Used with Serial Port Commands.....	22
7.	Error Codes	23
8.	Replacement Parts and Accessories	24

List of Figures

Figure	Title	Page
1.	How to Change the Batteries.....	8
2.	Calibration Setup with HyperTerminal	16

Introduction

The 700G Series Pressure Gauges (the Product) are high-accuracy digital pressure test gauges. Accurate to 0.05 % FS, the Products can be used as a calibration reference or in any application where high-accuracy pressure measurement is necessary.

The Product features user-configurable functions that include:

- Sampling rate
- Tare
- Damping
- Auto off
- Min Max

When the Product is configured, you can lock its settings and use password protection to prevent configuration changes.

How to Contact Fluke

To contact Fluke, call one of the following telephone numbers:

- Technical Support USA: 1-800-44-FLUKE (1-800-443-5853)
- Calibration/Repair USA: 1-888-99-FLUKE (1-888-993-5853)
- Canada: 1-800-36-FLUKE (1-800-363-5853)
- Europe: +31 402-675-200
- Japan: +81-3-6714-3114
- Singapore: +65-6799-5566
- Anywhere in the world: +1-425-446-5500

Or, visit Fluke's website at www.fluke.com.

To register your product, visit <http://register.fluke.com>.

To view, print, or download the latest manual supplement, visit <http://us.fluke.com/usen/support/manuals>.

Safety Information

A **Warning** identifies conditions and procedures that are dangerous to the user. A **Caution** identifies conditions and procedures that can cause damage to the Product or the equipment under test.

Warning

To prevent possible electrical shock, fire, or personal injury:

- Only assemble and operate high-pressure systems if you know the correct safety procedures. High-pressure liquids and gases are hazardous and the energy from them can be released without warning.
- Use the Product only as specified, or the protection supplied by the Product can be compromised.
- The battery door must be closed and locked before you operate the Product.
- Replace the batteries when the low battery indicator () shows to prevent incorrect measurements.
- Do not use the Product if it is damaged.
- Disable the Product if it is damaged.
- Read all safety information before you use the Product.

Caution

To prevent possible damage to Product or to equipment under test:

- If the display reads “OL” the range limit is exceeded and the pressure source must immediately be removed.
- Do not exceed the maximum torque allowed. Maximum torque allowed is 13,5 Nm = 10 ft lb.

Hazard Location Information/Approvals

Ex-Hazardous Areas

An Ex-hazardous area as used in this manual refers to an area made hazardous by the potential presence of flammable or explosive vapors. These areas are also referred to as hazardous locations, see NFPA 70 Article 500.

 [®] LR110460
Class I, Div. 2, Groups A-D

 II 3 G Ex nA IIB T6
KEMA 06ATEX0014 X
Ta=−10 °C... +55 °C

Special Conditions for Safe Use

Misuse

If the Product is exposed to overpressure or sudden physical shock (such as being dropped) examine it for any damage that can cause a safety concern. If necessary, return the Product for evaluation to Fluke. Refer to the How to Contact Fluke section.









⚠ Warning

To prevent possible fire, or personal injury, the Product is intended for installation only in locations providing adequate protection against the entry of solid foreign objects or water capable of impairing safety.

Symbols

Symbols used on the Product and in this manual are explained in Table 1.

Table 1. Symbols

Symbol	Meaning	Symbol	Meaning
	Risk of danger. Important information. See manual.		Conforms to European Union directives.
	Hazardous voltage. Risk of electrical shock.		Conforms to relevant North American Safety Standards.
	Pressure		This product complies with the WEEE Directive (2002/96/EC) marking requirements. The affixed label indicates that you must not discard this electrical/electronic product in domestic household waste. Product Category: With reference to the equipment types in the WEEE Directive Annex I, this product is classed as category 9 "Monitoring and Control Instrumentation" product. Do not dispose of this product as unsorted municipal waste. Go to Fluke's website for recycling information.
	Conforms to relevant Australian standards.		Conforms to ATEX requirements
	Conforms to relevant South Korean EMC Standards.		

Specifications

Available Input Ranges

See Ranges and Resolution table for available ranges in psi plus equivalent ranges and resolution for all engineering units.

Accuracy 700G Ranges

Positive Pressure.....	±0.05 % FS
Positive Pressure (700G01, 700G02)	±0.1 % FS
Vacuum	±0.1 % FS
Temperature Compensation	15 °C to 35 °C (59 °F to 95 °F) to rated accuracy

Note

For temperatures from -10 °C to 15 °C and 35 °C to 55 °C, add .003 % FS/°C

Accuracy 700RG Ranges

Positive Pressure.....	±0.04 % rdg ±0.01 % FS
Vacuum (700RG05)	±0.05 % FS
Vacuum (all other ranges)	±0.1 % FS
Temperature Compensation	0 °C to 50 °C (32 °F to 122 °F) to rated accuracy

Note

For temperatures from -10 °C to 0 °C and 50 °C to 55 °C, add .005 % FS/°C.

Media Compatibility

700G01, 700G02, 700G04, 700G05, 700RG05	any clean dry non-corrosive gas
All other ranges, 100 psi and above	any liquids or gases compatible with 316 stainless steel

Environmental

Operating Temperature.....	-10 °C to +55 °C (14 °F to 131 °F) Storage with batteries per battery manufacturer specification within storage specification below.
Storage (without batteries)	-40 °C to +70 °C (-40 °F to +158 °F)
Humidity	10 % to 95 % RH Non-condensing
Pollution Degree	2
IP Rating.....	64 (with boot and serial-port plug installed)
Electromagnetic Environment.....	IEC 61326-1, Portable

Electromagnetic Compatibility.....Applies to use in Korea only. Class A equipment (Industrial Broadcasting & Communication Equipment) ^[1]

[1] This Product meets requirements for industrial (Class A) electromagnetic wave equipment and the seller or user should take notices of it. This equipment is intended for use in business environments and is not to be used in homes.

Mechanical Specifications

Dimensions 11.4 x 12.7 (cm), depth = 3.7 cm
(4.5 x 5 (in), depth= 1.5 in)

Pressure

Connection ¼ in NPT Male

Housing Cast ZNAl

Display

5-1/2 Digits, 16.53 mm (0.65 in) high

20-Segment bar graph, 0 to 100 %

Power

Battery three size AA alkaline batteries

Battery Life 1,500 hours without backlight
(continuous on), 2,000 hours at slow
sample rate

Ranges and Resolution

Model Number		700G01	700G02	700G04	700G05	700G06	700G27	700G07	700G08	700G10	700G29	700G30	700G31
Pressure Range (psi)		0.4	1	15	30	100	300	500	1000	2000	3000	5000	10000
Vacuum Range (psi)		-0.4	-1	-14	-14	-12	-12	-12	-14	-14	-14	-14	-14
Burst Pressure (psi)		3	5	60	120	400	1200	2000	4000	8000	10000	15000	20000
Proof Pressure (psi)		1	3	30	60	200	600	1000	2000	4000	6000	10000	15000
Engineering Unit	Factor												
psi	1.0000	0.4000	1.0000	15.000	30.000	100.00	300.00	500.00	1000.0	2000.0	3000.0	5000.0	10000
bar	0.06894757	0.0276	0.0689	1.0342	2.0684	6.8948	20.684	34.474	68.948	137.90	206.84	344.74	689.48
mbar	68.94757	27.579	68.948	1034.2	2068.4	6894.8	20684	34474	68948	*	*	*	*
kPa	6.894757	2.7579	6.8948	103.42	206.84	689.48	2068.4	3447.4	6894.8	13790	20684	34474	68948
MPa	0.006894757	0.0028	0.0069	0.1034	0.2068	0.6895	2.0684	3.4474	6.8948	13.790	20.684	34.474	68.948
kg/cm2	0.07030697	0.0281	0.0703	1.0546	2.1092	7.0307	21.092	35.153	70.307	140.61	210.92	351.53	703.07
mmHg @ 0°C	51.71507	20.686	51.715	775.73	1551.5	5171.5	15515	25858	51715	*	*	*	*
inHg @ 0°C	2.03603	0.8144	2.0360	30.540	61.081	203.60	610.81	1018.0	2036.0	4072.1	6108.1	10180	20360
cmH2O @ 4°C	70.3089	28.124	70.309	1054.6	2109.3	7030.9	21093	35154	70309	*	*	*	*
cmH2O @ 20°C	70.4336	28.173	70.434	1056.5	2113.0	7043.4	21130	35217	70434	*	*	*	*
mmH2O @ 4°C	703.089	281.24	703.09	10546	21093	70309	*	*	*	*	*	*	*
mmH2O @ 20°C	704.336	281.73	704.34	10565	21130	70434	*	*	*	*	*	*	*
mH2O @ 4°C	0.703089	0.2812	0.7031	10.546	21.093	70.309	210.93	351.54	703.09	1406.2	2109.3	3515.4	7030.9
mH2O @ 20°C	0.704336	0.2817	0.7043	10.565	21.130	70.434	211.30	352.17	704.34	1408.7	2113.0	3521.7	7043.4
inH2O @ 4°C	27.68067	11.072	27.681	415.21	830.42	2768.1	8304.2	13840	27681	55361	83042	*	*
inH2O @ 20°C	27.72977	11.092	27.730	415.95	831.89	2773.0	8318.9	13865	27730	55460	83189	*	*
inH2O @ 60°F	27.70759	11.083	27.708	415.61	831.23	2770.8	8312.3	13854	27708	55415	83123	*	*
ftH2O @ 4°C	2.306726	0.9227	2.3067	34.601	69.202	230.67	692.02	1153.4	2306.7	4613.5	6920.2	11534	23067
ftH2O @ 20°C	2.310814	0.9243	2.3108	34.662	69.324	231.08	693.24	1155.4	2310.8	4621.6	6932.4	11554	23108
ftH2O @ 60°F	2.308966	0.9236	2.3090	34.634	69.269	230.90	692.69	1154.5	2309.0	4617.9	6926.9	11545	23090
ft Sea Water	2.24719101	0.8989	2.2472	33.708	67.416	224.72	674.16	1123.6	2247.2	4494.4	6741.6	11236	22472
m Sea Water	0.68494382	0.2740	0.6849	10.274	20.548	68.494	205.48	342.47	684.94	1369.9	2054.8	3424.7	6849.4
Torr	51.71507	20.686	51.715	775.73	1551.5	5171.5	15515	25858	51715	*	*	*	*

* - range will not be displayed due to limitations on display resolution. In all cases, resolution is limited to 100,000 counts.

Model Number		700GA4	700GA5	700GA6	700GA27	700RG05	700RG06	700RG07	700RG08	700RG29	700RG30	700RG31
Pressure Range (psi)		15 psia	30 psia	100 psia	300 psia	30	100	500	1000	3000	5000	10000
Vacuum Range (psi)		0 psia	0 psia	0 psia	0 psia	-14	-12	-12	-14	-14	-14	-14
Burst Pressure (psi)		60	120	400	1200	90	400	2000	4000	10000	15000	20000
Proof Pressure (psi)		30	60	200	600	60	200	1000	2000	6000	10000	15000
Engineering Unit	Factor											
psi	1.0000	15.000	30.000	100.00	300.00	30.000	100.000	500.00	1000.00	3000.0	5000.0	10000.0
bar	0.06894757	1.0342	2.0684	6.8948	20.684	2.0684	6.8948	34.474	68.948	206.84	344.74	689.48
mbar	68.94757	1034.2	2068.4	6894.8	20684	2068.4	6894.8	34474	68948	*	*	*
kPa	6.894757	103.42	206.84	689.48	2068.4	206.84	689.48	3447.4	6894.8	20684	34474	68948
MPa	0.006894757	0.1034	0.2068	0.6895	2.0684	0.2068	0.6895	3.4474	6.8948	20.684	34.474	68.948
kg/cm2	0.07030697	1.0546	2.1092	7.0307	21.092	2.1092	7.0307	35.153	70.307	210.92	351.53	703.07
mmHg @ 0°C	51.71507	775.73	1551.5	5171.5	15515	1551.5	5171.5	25858	51715	*	*	*
inHg @ 0°C	2.03603	30.540	61.081	203.60	610.81	61.081	203.60	1018.0	2036.0	6108.1	10180	20360
cmH2O @ 4°C	70.3089	1054.6	2109.3	7030.9	21093	2109.3	7030.9	35154	70309	*	*	*
cmH2O @ 20°C	70.4336	1056.5	2113.0	7043.4	21130	2113.0	7043.4	35217	70434	*	*	*
mmH2O @ 4°C	703.089	10546	21093	70309	*	21093	70309	*	*	*	*	*
mmH2O @ 20°C	704.336	10565	21130	70434	*	21130	70434	*	*	*	*	*
mH2O @ 4°C	0.703089	10.546	21.093	70.309	210.93	21.093	70.309	351.54	703.09	2109.3	3515.4	7030.9
mH2O @ 20°C	0.704336	10.565	21.130	70.434	211.30	21.130	70.434	352.17	704.34	2113.0	3521.7	7043.4
inH2O @ 4°C	27.68067	415.21	830.42	2768.1	8304.2	830.42	2768.1	13840	27681	83042	*	*
inH2O @ 20°C	27.72977	415.95	831.89	2773.0	8318.9	831.89	2773.0	13865	27730	83189	*	*
inH2O @ 60°F	27.70759	415.61	831.23	2770.8	8312.3	831.23	2770.8	13854	27708	83123	*	*
ftH2O @ 4°C	2.306726	34.601	69.202	230.67	692.02	69.202	230.67	1153.4	2306.7	6920.2	11534	23067
ftH2O @ 20°C	2.310814	34.662	69.324	231.08	693.24	69.324	231.08	1155.4	2310.8	6932.4	11554	23108
ftH2O @ 60°F	2.308966	34.634	69.269	230.90	692.69	69.269	230.90	1154.5	2309.0	6926.9	11545	23090
ft Sea Water	2.24719101	33.708	67.416	224.72	674.16	67.416	224.72	1123.6	2247.2	6741.6	11236	22472
m Sea Water	0.68494382	10.274	20.548	68.494	205.48	20.548	68.494	342.47	684.94	2054.8	3424.7	6849.4
Torr	51.71507	775.73	1551.5	5171.5	15515	1551.5	5171.5	25858	51715	*	*	*

* - range will not be displayed due to limitations on display resolution. In all cases, resolution is limited to 100,000 counts.

Maintenance

How to Clean the Product

Clean the Product with a soft cloth dampened with water or water and weak soap.

⚠ Caution

To prevent possible damage to the Product, do not use solvents or abrasive cleansers.

⚠ Caution

For safe operation and maintenance of the product:

- **Repair the Product before use if the battery leaks.**
- **Remove batteries to prevent battery leakage and damage to the Product if it is not used for an extended period.**
- **Be sure that the battery polarity is correct to prevent battery leakage.**
- **Have an approved technician repair the Product.**

How to Change the Batteries

⚠⚠ Warning

To prevent possible electrical shock, fire, or personal injury, batteries must only be changed in an area known to be non-hazardous. Explosion hazard.

To change the batteries, see Figure 1:

1. Remove the Product holster.
2. Use a Phillips screwdriver to loosen the captive screw on the battery door.
3. Remove the battery door.
4. Replace the three AA batteries.
5. Install the battery door again.
6. Tighten the captive screw.
7. Put the Product back into the holster.

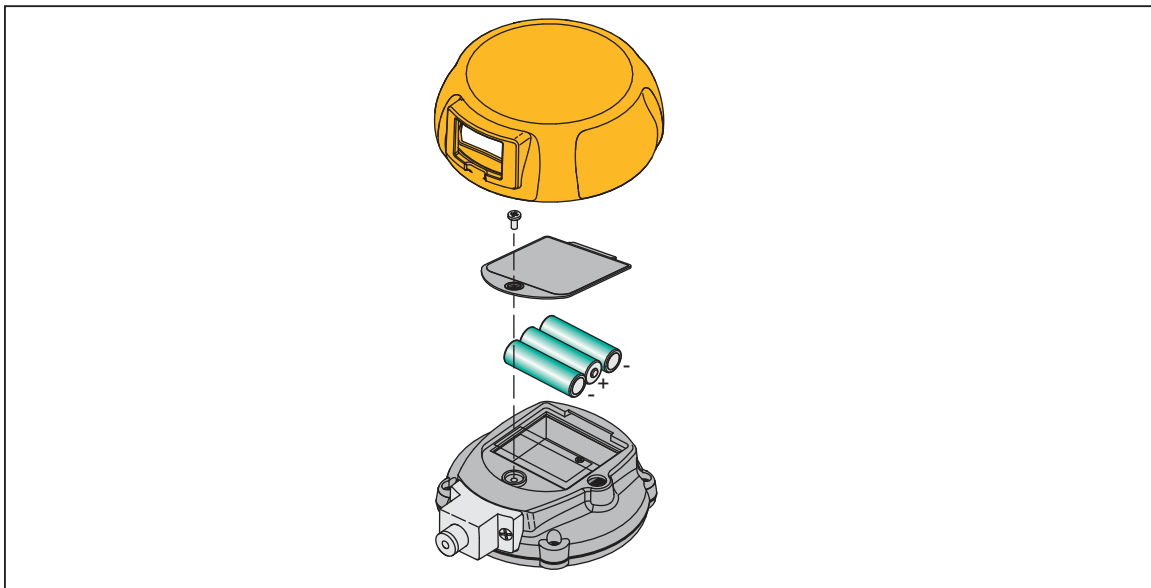

Figure 1. How to Change the Batteries

gvv002.eps

Performance Verification Tests

Fluke recommends certification each year. To re-certify, do the verification procedure. If test points are out of tolerance, calibrate the Product and then re-verify. Use the subsequent tests to make sure that the Product is in its specification limits.

Required Equipment

The equipment necessary for verification of the Product is shown in Table 2. If these instruments are not available, you can replace them with other instruments that have the same minimal specification requirements.

Table 2. Equipment Required for Verification

Equipment	Minimum Specification	Recommended Model
Dead Weight Tester	300 to 10,000 psig Accuracy: 0.01 % of Reading	Pressurement P3000, P3100
Low Pressure Controller/Calibrator	100 inH ₂ O Accuracy: 0.02 % of Range	Ruska 7250LP
Absolute Pressure Controller/Calibrator	300 psia Accuracy: 0.01 % of Reading	Ruska 7250xi

How to Verify Pressure

For each procedure there is a table of test points and permitted Product indications. If the result of the test is not in the range shown, the Unit Under Test (UUT) is out of tolerance and must be calibrated or repaired. For Product support, see the “How to Contact Fluke” section. The 700G01 and 700G02 require a low-pressure standard such as the Ruska 7250LP. Because absolute pressure of deadweight can be complex, a Controller/Calibrator is recommended for the 700GA Gauges.

Follow these general instructions for all the tests:

- Make sure the batteries are fully charged.
 - Let the verification equipment warm-up for its specified time.
 - For each test, make sure the verification equipment is stable and that the “unsettled” annunciator on the UUT is not shown.
1. Carefully attach the pressure fitting of the pressure standard to the pressure port of the UUT.

Note

Use plenty of PTFE tape when you attach the pressure fitting.

The display reads **0.00 PSI** with the pressure standard opened to ambient air. If it does not, push **ZERO** until the display shows **0.00 PSI**.

2. Set up the pressure standard for the sequence of psi inputs from Table 3. These inputs will be put into the pressure port of the UUT.
3. Make sure the pressure has become stable at each input before you verify the display indication.
4. Apply the inputs from Table 3.
5. Carefully vent all pressure and disconnect the UUT from the pressure standard.

Table 3. Verification Points (In psi)

700G01 0.4 psi			700G02 1 psi		
Input Pressure	Lower Limit	Upper Limit	Input Pressure	Lower Limit	Upper Limit
0.3600	0.3604	0.3596	1.0000	1.0010	0.9990
0.3300	0.3304	0.3296	0.9000	0.9010	0.8990
0.2500	0.2504	0.2496	0.7000	0.7010	0.6990
0.1700	0.1704	0.1696	0.5000	0.5010	0.4990
0.0900	0.0904	0.0896	0.3000	0.3010	0.2990
0.0300	0.0304	0.0296	0.1000	0.1010	0.0990
0.0000	0.0004	-0.0004	0.0000	0.0010	-0.0010
-0.0600	-0.0596	-0.0604	-0.1000	-0.0990	-0.1010
-0.1400	-0.1396	-0.1404	-0.3000	-0.2990	-0.3010
-0.2300	-0.2296	-0.2304	-0.6000	-0.5990	-0.6010
-0.3000	-0.2996	-0.3004	-0.8000	-0.7990	-0.8010
-0.3600	-0.3596	-0.3604	-1.0000	-0.9990	-1.0010
700G04 15 psi			700G05 30 psi		
Input Pressure	Lower Limit	Upper Limit	Input Pressure	Lower Limit	Upper Limit
15.000	14.993	15.008	30.000	29.985	30.015
14.000	13.993	14.008	28.125	28.110	28.140
12.000	11.993	12.008	24.000	23.985	24.015
9.750	9.743	9.758	19.500	19.485	19.515
7.500	7.493	7.508	15.250	15.235	15.265
5.500	5.493	5.508	11.000	10.985	11.015
3.250	3.243	3.258	6.750	6.735	6.765
1.250	1.243	1.258	2.500	2.485	2.515
0.000	-0.008	0.008	0.000	-0.015	0.015
-5.000	-5.015	-4.985	-5.000	-5.030	-4.970
-10.000	-10.015	-9.985	-10.000	-10.030	-9.970
-14.000*	-14.015	-13.985	-14.000*	-14.030	-13.970

Table 3. Verification Points (In psi) (cont.)

700G06 100 psi			700G27 300 psi		
Input Pressure	Lower Limit	Upper Limit	Input Pressure	Lower Limit	Upper Limit
100.00	99.95	100.05	300.00	299.85	300.15
93.75	93.70	93.80	281.25	281.10	281.40
81.25	81.20	81.30	243.75	243.60	243.90
68.75	68.70	68.80	206.25	206.10	206.40
56.25	56.20	56.30	168.75	168.60	168.90
43.75	43.70	43.80	131.25	131.10	131.40
31.25	31.20	31.30	93.75	93.60	93.90
18.75	18.70	18.80	56.25	56.10	56.40
6.25	6.20	6.30	18.75	18.60	18.90
0.00	-0.05	0.05	0.00	-0.15	0.15
-6.00	-6.10	-5.90	-6.00	-6.30	-5.70
-12.00*	-12.10	-11.90	-12.00*	-12.30	-11.70
700G07 500 psi			700G08 1000 psi		
Input Pressure	Lower Limit	Upper Limit	Input Pressure	Lower Limit	Upper Limit
500.00	499.75	500.25	1000.0	999.5	1000.5
468.75	468.50	469.00	937.5	937.0	938.0
406.25	406.00	406.50	812.5	812.0	813.0
343.75	343.50	344.00	687.5	687.0	688.0
281.25	281.00	281.50	562.5	562.0	563.0
218.75	218.50	219.00	437.5	437.0	438.0
156.25	156.00	156.50	312.5	312.0	313.0
93.75	93.50	94.00	187.5	187.0	188.0
31.25	31.00	31.50	62.5	62.0	63.0
0.00	-0.25	0.25	0.0	-0.5	0.5
-6.00	-6.50	-5.50			
-12.00*	-12.50	-11.50			

Table 3. Verification Points (In psi) (cont.)

700G10 2000 psi			700G29 3000 psi		
Input Pressure	Lower Limit	Upper Limit	Input Pressure	Lower Limit	Upper Limit
2000.0	2001.0	1999.0	3000.0	2998.5	3001.5
1800.0	1801.0	1799.0	2812.5	2811.0	2814.0
1600.0	1601.0	1599.0	2437.5	2436.0	2439.0
1300.0	1301.0	1299.0	2062.5	2061.0	2064.0
1100.0	1101.0	1099.0	1687.5	1686.0	1689.0
900.0	901.0	899.0	1312.5	1311.0	1314.0
600.0	601.0	599.0	937.5	936.0	939.0
300.0	301.0	299.0	562.5	561.0	564.0
100.0	101.0	99.0	187.5	186.0	189.0
0.0	1.0	-1.0	0.0	-1.5	1.5
700G30 5000 psi			700G31 10000 psi		
Input Pressure	Lower Limit	Upper Limit	Input Pressure	Lower Limit	Upper Limit
5000.0	4997.5	5002.5	10000	9995	10005
4687.5	4685.0	4690.0	9000	8995	9005
4062.5	4060.0	4065.0	7500	7495	7505
3437.5	3435.0	3440.0	6500	6495	6505
2812.5	2810.0	2815.0	5500	5495	5505
2187.5	2185.0	2190.0	4500	4495	4505
1562.5	1560.0	1565.0	1500	1495	1505
937.5	935.0	940.0	500	495	505
312.5	310.0	315.0	0.	-5	5
0.0	-2.5	2.5			

Table 3. Verification Points (In psi) (cont.)

Absolute Gauges					
700GA4 15 psia			700GA5 30 psia		
Input Pressure	Lower Limit	Upper Limit	Input Pressure	Lower Limit	Upper Limit
15.000	15.008	14.992	30.000	30.015	29.985
14.000	14.008	13.992	28.000	28.015	27.985
12.500	12.508	12.492	25.000	25.015	24.985
10.000	10.008	9.992	20.000	20.015	19.985
8.000	8.008	7.992	16.500	16.515	16.485
6.500	6.508	6.492	13.000	13.015	12.985
4.500	4.508	4.492	9.000	9.015	8.985
3.000	3.008	2.992	6.000	6.015	5.985
1.000	1.008	0.992	2.000	2.015	1.985
0.350	0.358	0.342	0.350	0.365	0.335
700GA6 100 psia			700GA27 300 psia		
Input Pressure	Lower Limit	Upper Limit	Input Pressure	Lower Limit	Upper Limit
100.00	100.05	99.95	300.00	300.15	299.85
93.00	93.05	92.95	281.00	281.15	280.85
81.00	81.05	80.95	243.00	243.15	242.85
68.00	68.05	67.95	206.00	206.15	205.85
56.00	56.05	55.95	168.00	168.15	167.85
43.00	43.05	42.95	131.00	131.15	130.85
31.00	31.05	30.95	93.00	93.15	92.85
18.00	18.05	17.95	56.00	56.15	55.85
6.00	6.05	5.95	18.00	18.15	17.85
0.50	0.55	0.45	5.00	5.15	4.85
			0.50	0.65	0.35

Table 3. Verification Points (In psi) (cont.)

Reference Gauges					
700RG5 30 psi			700RG6 100 psi		
Input Pressure	Lower Limit	Upper Limit	Input Pressure	Lower Limit	Upper Limit
30.000	30.015	29.985	100.000	100.050	99.950
24.000	24.015	23.985	80.000	80.042	79.958
18.000	18.015	17.985	60.000	60.034	59.966
12.000	12.015	11.985	40.000	40.026	39.974
6.000	6.015	5.985	20.000	20.018	19.982
0.000	0.015	-0.015	0.000	0.010	-0.010
-5.000	-4.970	-5.030	-6.000	-5.900	-6.100
-10.000	-9.970	-10.030	-12.000*	-11.900	-12.100
-14.000*	-13.970	-14.030			
700RG7 500 psi			700RG8 1000 psi		
Input Pressure	Lower Limit	Upper Limit	Input Pressure	Lower Limit	Upper Limit
500.00	500.25	499.75	1000.00	1000.50	999.50
400.00	400.21	399.79	800.00	800.42	799.58
300.00	300.17	299.83	600.00	600.34	599.66
200.00	200.13	199.87	400.00	400.26	399.74
100.00	100.09	99.91	200.00	200.18	199.82
0.00	0.05	-0.05	0.00	0.10	-0.10
-6.00	-5.50	-6.50			
-12.00*	-11.50	-12.50			

Table 3. Verification Points (In psi) (cont.)

700RG29 3000 psi			700RG30 5000 psi		
Input Pressure	Lower Limit	Upper Limit	Input Pressure	Lower Limit	Upper Limit
3000.0	3001.5	2998.5	5000.0	5002.5	4997.5
2400.0	2401.3	2398.7	4000.0	4002.1	3997.9
1800.0	1801.0	1799.0	3000.0	3001.7	2998.3
1200.0	1200.8	1199.2	2000.0	2001.3	1999.1
600.0	600.5	599.5	1000.0	1000.9	999.1
0.0	0.3	-0.3	0.0	0.5	-0.5
700RG31 10000 psi					
Input Pressure	Lower Limit	Upper Limit			
10000.0	10005.0	9995.0			
9000.0	9004.6	8995.4			
7500.0	7504.0	7496.0			
6500.0	6503.6	6496.4			
5500.0	5503.2	5496.8			
4500.0	4502.8	4497.2			
1500.0	1501.6	1498.4			
500.0	501.2	498.8			
0.0	1.0	-1.0			
*At altitudes -14 psi or -12 psi may not be possible. Replace with a local near-vacuum point when necessary.					

Calibration Adjustment

Calibration adjustment is done electronically by internal software with the Product case closed. The recommended adjustment procedure is a 2-point adjust that adjusts a low and high point. This adjustment can be applied to any of the 700 family of gauges. It is the only adjustment that may be used with a 700RG ranges.

Note

This is an ambient temperature calibration, and must be done at an ambient temperature of $23\text{ }^{\circ}\text{C} \pm 3\text{ }^{\circ}\text{C}$ ($72\text{ }^{\circ}\text{F} \pm 5\text{ }^{\circ}\text{F}$). Calibration out of this temperature range voids the temperature compensation software in the Product.

Test Equipment

For verification and calibration adjustment, pressure and/or vacuum standards that can make and show pressures from vacuum to the full-scale range of the UUT are necessary. A TUR standard of 4:1 or better is necessary to keep the Product at its specified accuracy.

Connections

The Product uses a $\frac{1}{4}$ inch NPT male connection in the pressure input port. Different adapters can be necessary to connect to the pressure standard. Always make sure the hose, tubing, and fittings. Have a rated working pressure at or above the pressure of the unit. It is also important that there be no leaks when you calibrate the Product. Use Teflon tape where necessary.

Enter 2-Point Adjust Mode

Follow the instructions for serial interface setup in the next section. Figure 2 can be used to guide setup if HyperTerminal will be used.

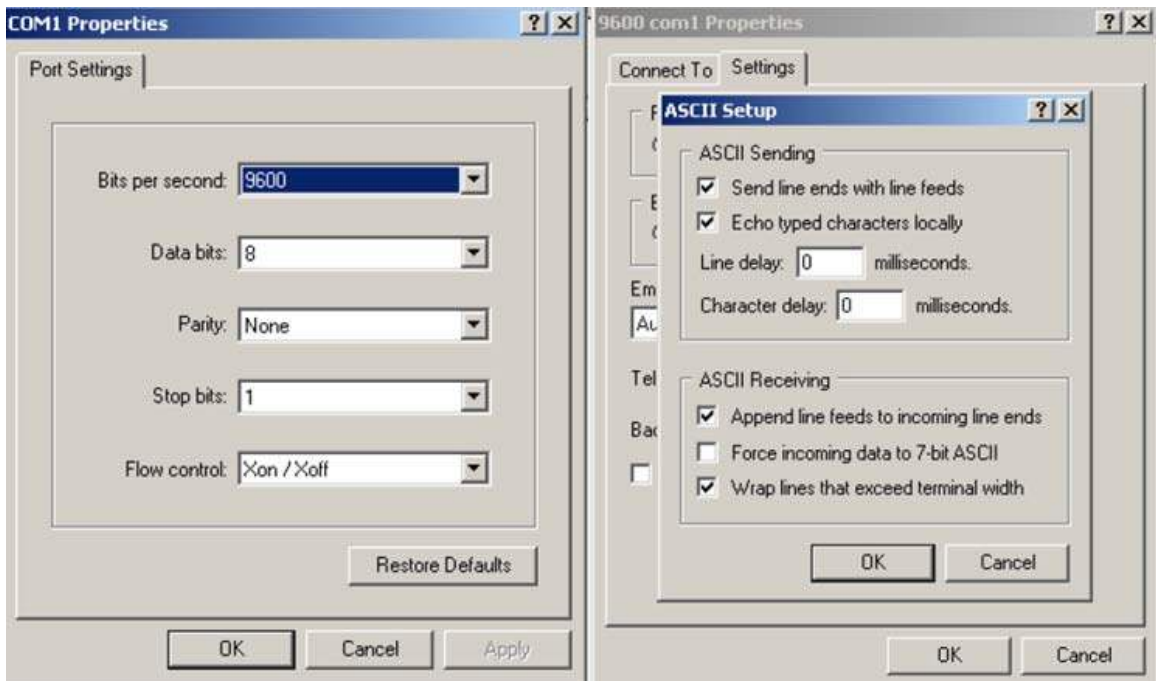

Figure 2. Calibration Setup with HyperTerminal

ht.bmp

1. Connect the PC to the Product with the interface cable that comes with 700G/TRACK software.
2. After all connections have been made, vent the Product to atmosphere and send this command: OFFSET_ADJ?
3. Note the value returned.
4. For absolute units, apply a vacuum of <0.35 psiA, the applied vacuum should be used for N in the OFFSET_ADJUST command.
5. When the pressure is stable, send OFFSET_ADJ N, where N is the pressure given from the OFFSET_ADJ? command.
6. Send the GAIN_ADJ? command.
7. Note the value returned.
8. Use an appropriate pressure standard to input a value equal or close to the noted value. When the pressure is stable send, GAIN_ADJ N, where N is the entered pressure.
9. Reset the power with the power button to save the calibration.

Two-point calibration is complete. Full adjustment may be used when the Product errors are not linear.

Full Adjust

Caution

To avoid loss of data, do not use this procedure on a 700RG gauge. To do this would over write the characterized values that make it a reference gauge.

All calibration commands and adjustments are done with the keypad. Eight calibration points are used in the adjustment. They go from full-scale to zero at pressures that equal 100 %, 87.5 %, 75 %, 62.5 %, 50 %, 37.5 %, 25 %, 12.5 %, and 0 % of full scale plus vacuum.

After you have made the connections, turn on the power while you hold **CONFIG**. Use **▲** and **▼** to enter the password: **101** then push **ENTER**. If you went into calibration mode correctly, the display will show **CAL**. The pressure value shown will be the full-scale value of the Product. For Calibration points and their values, see Table 4.

Procedure Example

Note

This example uses a 700G07 Pressure Gauge (maximum pressure 500.00 psi). Apply the shown pressures necessary for your Product as shown in Table 4 .

The Product will prompt you for the necessary pressure at each calibration point.

1. Use the pressure standard to output 500.00 psi (100 %). After the output is stable, push **ENTER** to continue. As the Product measures, the screen will show ———-. When measurements are complete the screen will show the calibration value.
2. Use the pressure standard to output 437.50 psi (87.5 %). After the output is stable, push **ENTER** to continue. As the Product measures, the screen will show ———-. When measurements are complete the screen will show the calibration value.
3. Use the Pressure Standard to output 375.00 psi (75 %). After the output is stable,

- push **ENTER** to continue. As the Product measures, the screen will show _____. When measurements are complete the screen will show the calibration value.
4. Use the Pressure Standard to output 312.50 psi (62.5 %). After the output is stable, push **ENTER** to continue. As the Product measures, the screen will show _____. When measurements are complete the screen will show the calibration value.
 5. Use the Pressure Standard to output 250.00 psi (50 %). After the output is stable, push **ENTER** to continue. As the Product measures, the screen will show _____. When measurements are complete the screen will show the calibration value.
 6. Use the Pressure Standard to output 187.50 psi (37.5 %). After the output is stable, push **ENTER** to continue. As the Product measures, the screen will show _____. When measurements are complete the screen will show the calibration value.
 7. Use the Pressure Standard to output 125.00 psi (25 %). After the output is stable, push **ENTER** to continue. As the Product measures, the screen will show _____. When measurements are complete the screen will show the calibration value.
 8. Use the Pressure Standard to output 62.50 psi (12.5 %). After the output is stable, push **ENTER** to continue. As the Product measures, the screen will show _____. When measurements are complete the screen will show the calibration value.
 9. Use the Pressure Standard to output 0.00 psi. After the output is stable, push **ENTER** to continue. As the Product measures, the screen will show _____. When measurements are complete the screen will show the calibration value.

Note

Only some ranges use vacuum calibration. If your Product does not, then this step can be skipped and calibration is complete.

10. Use the Pressure Standard to output -12.00 psi. After the output is stable, push **ENTER** to continue. As the Product measures, the screen will show _____. When the measurements are complete, a Product reset occurs and the Product turns off then turns on as usual.

Table 4. Calibration Points

Model Number	700G01	700G02	700G04	700G05	700G05	700G27	700G07	700G08
Pressure Range (psi)	0.4	1	15	30	100	300	500	1000
Calibration Point 1	0.3600	1.0000	15.000	30.000	100.00	300.00	500.00	1000.0
Calibration Point 2	0.2880	0.8000	13.000	25.500	87.50	262.50	437.50	875.0
Calibration Point 3	0.2080	0.6000	10.750	21.500	75.00	225.00	375.00	750.0
Calibration Point 4	0.1280	0.4000	8.500	17.000	62.50	187.50	312.50	625.0
Calibration Point 5	0.0480	0.2000	6.500	12.750	50.00	150.00	250.00	500.0
Calibration Point 6	0.0000	0.0000	4.300	8.500	37.50	112.50	187.50	375.0
Calibration Point 7	-0.0900	-0.2500	2.150	4.250	25.00	75.00	125.00	250.0
Calibration Point 8	-0.1800	-0.5000	0.000	0.000	12.50	37.50	62.50	125.0
Calibration Point 9	-0.2700	-0.7500	-7.000	-7.000	0.00	0.00	0.00	0.0
Calibration Point 10	-0.3600	-1.0000	-14.000	-14.000	-12.00	-12.00	-12.00	-12.0
Calibration Point 11								
Model Number	700G10	700G29	700G30	700G31	700GA4	700GA5	700GA6	700GA27
Pressure Range (psi)	2000	3000	5000	10000	15 psia	30 psia	100 psia	300 psia
Calibration Point 1	2000.0	3000.0	5000.0	10000	15.000	30.000	100.00	300.00

Table 4. Calibration Points (Cont.)

Model Number	700G10	700G29	700G30	700G31	700GA4	700GA5	700GA6	700GA27
Calibration Point 2	1750.0	2625.0	4375.0	9300	13.125	26.250	87.50	262.50
Calibration Point 3	1500.0	2250.0	3750.0	8000	11.000	22.500	75.00	225.00
Calibration Point 4	1250.0	1875.0	3125.0	6500	25.000	18.750	62.50	187.50
Calibration Point 5	1000.0	1500.0	2500.0	5000	9.375	15.000	50.00	150.00
Calibration Point 6	750.0	1125.0	1875.0	3900	7.500	11.250	37.50	112.50
Calibration Point 7	500.0	750.0	1250.0	2800	5.625	7.500	25.00	75.00
Calibration Point 8	250.0	375.0	625.0	1800	3.750	3.750	12.50	37.50
Calibration Point 9	0.0	0.0	0.0	1000	1.875	0.300	0.40	0.50
Calibration Point 10				500	0.300			
Calibration Point 11				0				

Serial Interface

Use terminal communication software on a PC to set up terminal communication. An RS-232 to USB cable is necessary. This cable comes with 700G/TRACK Software. Use these terminal parameters:

- Bits per second: 9600
- Data bits: 8
- Parity: None
- Stop bits: 1
- Flow control: None
- Local echo: on

List of Commands

Table 5 shows the commands that the Product uses to communicate. Send these commands from the PC to set up the Product or to take a measurement.

Table 5. Commands

Command	Description
CAL_START	Puts the calibrator in calibration mode
*CLS	Deletes the error queue
FAULT?	Shows an error code from the error queue
*IDN?	Identification query. Shows the manufacturer, model number, and firmware revision level of the calibrator
TARE	Tares the offset pressure of the measurement on the calibrator
TARE?	Shows the current tare value
PRES_UNIT?	Shows the pressure unit for the upper display
PRES_UNIT	Sets the pressure unit for the display
ZERO_MEAS	Zeros the pressure of the calibrator
ZERO_MEAS?	Shows the current zero offset value
MINMAX_RST	Resets the minimum and maximum recorded values
MIN?	Shows the minimum recorded value
MAX?	Shows the maximum recorded value
HC_OFF	Turns off the Product
HC_DFLT	Sets auto-off defaults
TEMP?	Shows temperature in the units that you choose
HC_COMP_OFF	Turns off temperature compensation
HC_COMP_ON	Turns on temperature compensation
HC_COMP?	Shows state of temperature compensation
HC_RD_2410?	Shows 2410 ADC counts
HC_SI_OFF	Turns off SI mode
HC_SI_ON	Turns on SI mode
CAL_STORE	Keeps calibration data
HC_AUTO_OFF	Turns off auto shutdown
HC_AUTO_ON	Turns on auto shutdown
CUST_MULT?	Sets the multiplier for the custom unit type
STREAM_OFF	Turns of streaming data
STREAM_ON	Turns on streaming data
HC_TEMP?	Same as TEMP?
VAL?	Shows the measured pressure value in selected units
HC_CMD_LIST	Prints a command list
TEMP_UNIT	Set a temperature unit
TEMP_UNIT?	Shows temperature unit

Parameter Units

The Product can be set to show the measurement units in Table 6.

Table 6. Measurement Units Used with Serial Port Commands

Units	Description
Psi	Pressure in pounds per square-inch
Bar	Pressure in bars
mBar	Pressure in millibars
Kg/cm2	Pressure in kilograms per centimeter squared
inH2O4C	Pressure in inches of water at 4 °C
inH2O20C	Pressure in inches of water at 20 °C
inH2O60F	Pressure in inches of water at 60 °F
mH2O4C	Pressure in meters of water at 4 °C
mH2O20C	Pressure in meters of water at 20 °C
cmH2O4C	Pressure in centimeters of water at 4 °C
cmH2O4C	Pressure in centimeters of water at 20 °C
mmH2O4C	Pressure in millimeters of water at 4 °C
mmH2O20C	Pressure in millimeters of water at 20 °C
MSW	Pressure in meters of salt water
ftH2O4C	Pressure in feet of water at 4 °C
ftH2O20C	Pressure in feet of water at 20 °C
ftH2O60F	Pressure in feet of water at 60 °F
FTSW	Pressure in feet of salt water
inhg0C	Pressure in inches of mercury at 0 °C
mmHg0C	Pressure in millimeters of mercury at 0 °C
kPa	Pressure in kilopascals
mPa	Pressure in mega Pascal
Torr	Pressure in Torr
CUST	Pressure in custom-defined units
Far	Temperature in Fahrenheit
Cel	Temperature in Celsius

Error Codes

A list of error codes are in Table 7.

Table 7. Error Codes

Error	Description
101	A non-numeric entry was received where a numeric entry is necessary
102	Too many significant digits entered
103	Invalid units or parameter value received
105	Entry is above the upper limit of the allowable range
106	Entry is below the lower limit of the allowable range
108	A required command parameter was missing
109	An invalid pressure unit was received
117	An unknown command was received
120	The serial input buffer overflowed
121	Too many entries in the command line
122	Pressure module not connected

Replacement Parts and Accessories

Table 8 lists the customer replaceable parts. Replacement parts can be ordered from Fluke Corporation and its approved representatives. Use the part number when you order the replacement part or accessory. See the “How to Contact Fluke” section.

Table 8. Replacement Parts and Accessories

Part Number	Description
4110667	Fluke-700G, Decal, Front
4110671	Fluke-700G, Decal, Back
4374013	Decal, Top Case Identification For 700G10 2000 psia
4374024	Decal, Top Case Identification For 700G01 10 IN/H2O
4374036	Decal, Top Case Identification For 700G02 30 IN/H2O
4374049	Decal, Top Case Identification For 700GA4 15 psia
4374051	Decal, Top Case Identification For 700GA5 30 psia
4374060	Decal, Top Case Identification For 700GA6 100 psia
4374072	Decal, Top Case Identification For 700GA27 300 psia
4374085	Decal, Top Case Identification For 700RG05 30 PSIG
4374097	Decal, Top Case Identification For 700RG06 100 PSIG
4374106	Decal, Top Case Identification For 700RG07 500 PSIG
4374114	Decal, Top Case Identification For 700RG08 1000 PSIG
4374123	Decal, Top Case Identification For 700RG29 3000 PSIG
4374138	Decal, Top Case Identification For 700RG30 5000 PSIG
4374145	Decal, Top Case Identification For 700RG31 10000 PSIG
4374161	Decal, Top Case Identification For 700G04 15 PSIG
4374177	Decal, Top Case Identification For 700G05 30 PSIG
4374189	Decal, Top Case Identification For 700G06 100 PSIG
4374192	Decal, Top Case Identification For 700G27 300 PSIG
4374200	Decal, Top Case Identification For 700G07 500 PSIG
4374217	Decal, Top Case Identification For 700G08 1000 PSIG
4374221	Decal, Top Case Identification For 700G29 3000 PSIG
4374239	Decal, Top Case Identification For 700G30 5000 PSIG
4374242	Decal, Top Case Identification For 700G31 10000 PSIG
4374256	Decal, Manifold Range 10in H2O 27mbar
4374263	Decal, Manifold Range 30in H2O 70mbar

Table 8. Replacement Parts and Accessories (cont.)

Part Number	Description
4374295	Decal, Manifold Range 150psi 10bar
4374301	Decal, Manifold Range 1500psi 100bar
4374312	Decal, Manifold Range 2000psi 140bar
4374320	Decal, Manifold Range 15psia 1bar
4374335	Decal, Manifold Range 30psia 2bar
4374347	Decal, Manifold Range 100psia 7bar
4374358	Decal, Manifold Range 300psia 20bar
4110680	Fluke-700G04, 15 Psi, Manifold Decal
4110698	Fluke-700G05, 30 Psi, Manifold Decal
4110705	Fluke-700G06, 100 Psi, Manifold Decal
4110710	Fluke-700G27, 300 Psi, Manifold Decal
4110722	Fluke-700G07, 500 Psi, Manifold Decal
4110731	Fluke-700G08, 1000 Psi, Manifold Decal
4110746	Fluke-700G29, 3000 Psi, Manifold Decal
4110754	Fluke-700G30, 5000 Psi, Manifold Decal
4110768	Fluke-700G31, 10000 Psi, Manifold Decal
4110779	Fluke-700G, Pressure Gauge, Boot
4123225	Fluke 700G/TRACK Software and Serial Cable
4098606	<i>700G Safety Information</i> (15 language)
4098593	700G CD-ROM (includes 15 language Users Manual)

