

**PVA-1500HE2/PVA-1500T2/
SolSensor-300V3**
Solmetric I-V Curve Tracer Kit

Users Manual

3/2024 (English)

©2024 Fluke Corporation. All rights reserved.

Specifications are subject to change without notice.

All product names are trademarks of their respective companies.

LIMITED WARRANTY AND LIMITATION OF LIABILITY

Each Fluke product is warranted to be free from defects in material and workmanship under normal use and service. The warranty period is 1 year and begins on the date of shipment. Parts, product repairs, and services are warranted for 90 days. This warranty extends only to the original buyer or end-user customer of a Fluke authorized reseller, and does not apply to fuses, disposable batteries, or to any product which, in Fluke's opinion, has been misused, altered, neglected, contaminated, or damaged by accident or abnormal conditions of operation or handling. Fluke warrants that software will operate substantially in accordance with its functional specifications for 90 days and that it has been properly recorded on non-defective media. Fluke does not warrant that software will be error free or operate without interruption.

Fluke authorized resellers shall extend this warranty on new and unused products to end-user customers only but have no authority to extend a greater or different warranty on behalf of Fluke. Warranty support is available only if product is purchased through a Fluke authorized sales outlet or Buyer has paid the applicable international price. Fluke reserves the right to invoice Buyer for importation costs of repair/replacement parts when product purchased in one country is submitted for repair in another country.

Fluke's warranty obligation is limited, at Fluke's option, to refund of the purchase price, free of charge repair, or replacement of a defective product which is returned to a Fluke authorized service center within the warranty period.

To obtain warranty service, contact your nearest Fluke authorized service center to obtain return authorization information, then send the product to that service center, with a description of the difficulty, postage and insurance prepaid (FOB Destination). Fluke assumes no risk for damage in transit. Following warranty repair, the product will be returned to Buyer, transportation prepaid (FOB Destination). If Fluke determines that failure was caused by neglect, misuse, contamination, alteration, accident, or abnormal condition of operation or handling, including overvoltage failures caused by use outside the product's specified rating, or normal wear and tear of mechanical components, Fluke will provide an estimate of repair costs and obtain authorization before commencing the work. Following repair, the product will be returned to the Buyer transportation prepaid and the Buyer will be billed for the repair and return transportation charges (FOB Shipping Point).

THIS WARRANTY IS BUYER'S SOLE AND EXCLUSIVE REMEDY AND IS IN LIEU OF ALL OTHER WARRANTIES, EXPRESS OR IMPLIED, INCLUDING BUT NOT LIMITED TO ANY IMPLIED WARRANTY OF MERCHANTABILITY OR FITNESS FOR A PARTICULAR PURPOSE. FLUKE SHALL NOT BE LIABLE FOR ANY SPECIAL, INDIRECT, INCIDENTAL OR CONSEQUENTIAL DAMAGES OR LOSSES, INCLUDING LOSS OF DATA, ARISING FROM ANY CAUSE OR THEORY.

Since some countries or states do not allow limitation of the term of an implied warranty, or exclusion or limitation of incidental or consequential damages, the limitations and exclusions of this warranty may not apply to every buyer. If any provision of this Warranty is held invalid or unenforceable by a court or other decision-maker of competent jurisdiction, such holding will not affect the validity or enforceability of any other provision.

Fluke Corporation
P.O. Box 9090
Everett, WA 98206-9090
U.S.A.

11/99

End User Software License and Hardware Agreement

CAREFULLY READ THE FOLLOWING AGREEMENT. BY OPENING THE PACKAGE OR CLICKING ON "I AGREE", YOU ARE CONSENTING TO BE BOUND BY AND ARE BECOMING A PARTY TO THIS AGREEMENT. IF YOU DO NOT AGREE TO ALL OF THE TERMS OF THIS AGREEMENT, CLICK "I DO NOT AGREE", DELETE ANY DOWNLOADED INSTALLATION FILES, AND, IF APPLICABLE, RETURN THIS PRODUCT TO THE PLACE OF PURCHASE FOR A FULL REFUND.

Software License Grant

The package or downloaded installation file contains:

1. I-V Curve Tracer TM PC software (PC Software),
2. I-V Curve Tracer I-V Measurement Unit software (Embedded Software), and
3. Related explanatory written materials (Documentation).

PC Software and *Embedded Software* includes any upgrades, modified versions, updates, additions, and copies of the software. *You* means the person or company who is being licensed to use the Software or Documentation. *We, us, and Fluke Corporation* mean Fluke® Corporation.

We hereby grant you a nonexclusive license to use one copy of the PC Software on any single computer, provided the PC Software is in use on only one computer at any time. The PC Software is *in use* on a computer when it is loaded into temporary memory (RAM) or installed into the permanent memory of a computer—for example, a hard disk, CD-ROM or other storage device. If the PC Software is permanently installed on the hard disk or other storage device of a computer (other than a network server) and one person uses that computer more than 80 % of the time, then that person may also use the PC Software on a portable or home computer.

We hereby grant you a nonexclusive license to use one copy of the Embedded Software when it is running within the relevant Solmetric hardware.

Software Title

Fluke remains the owner of all right, title and interest in the PC Software, Embedded Software, and Documentation.

Archival or Backup Copies of PC Software

You may either:

- make one copy of the PC Software solely for backup or archival purposes, or
- transfer the PC Software to a single hard disk, provided you keep the original solely for backup or archival purposes.

Things You May Not Do With the Software or Documentation

The PC Software, Embedded Software, and Documentation are protected by United States copyright laws and international treaties. You must treat the PC Software, Embedded Software, and Documentation like any other copyrighted material--for example a book. You may not:

- copy the Embedded Software
- copy the PC Software except to make archival or backup copies as provided above,
- modify or adapt the PC Software or Embedded Software or merge it into another program,
- reverse engineer, disassemble, decompile or make any attempt to discover the source code of the PC Software or Embedded Software,
- place the PC Software or Embedded Software onto a server so that it is accessible via a public network such as the Internet, or
- sublicense, rent, lease, or lend any portion of the PC Software, Embedded Software, or Documentation.

Transfers of PC Software or Embedded Software

You may transfer all your rights to use the PC Software and Documentation to another person or legal entity provided you transfer this Agreement, the PC Software, and Documentation, including all copies, updates and prior versions to such person or entity and that you retain no copies, including copies stored on computer.

You may transfer all your rights to use the Embedded Software and Documentation to another person or legal entity provided you transfer this Agreement, the hardware associated with the Embedded Software, and the Embedded Software and Documentation, including all copies, updates and prior versions to such person or entity and that you retain no copies, including copies stored on computer.

Table of Contents

Title	Page
Introduction	1
Contact Fluke	2
Safety Information	2
Specifications	3
PC Minimum System Requirements	3
Equipment	4
System Controls and Settings	7
Power Up the I-V Curve Tracer	8
Test Leads and Clips	9
Cover the Irradiance Sensor	10
Installation	10
Installation Procedure	10
Hardware Installation	10
Software Installation	10
Update the PV Equipment Databases	11
Charge the Battery	11
Charge the I-V Curve Tracer Battery	11
Charge SolSensor	12
The Wireless Network	13
Set Up and Use the I-V Curve Tracer and SolSensor	13
Set Up the I-V Curve Tracer	13
Set Up SolSensor	14
Mount SolSensor to a PV Module Frame	14
Optimize Wireless Transmission Range	17
Mount SolSensor on a Tripod	17
Connect to the Solar PV Equipment	19
I-V Measurements	21
Sweep Disabled	21
Over-Temperature Protection	22
Sweep-to-Sweep Delay and Thermal Capacity	22
High-Temperature Condition Operation	23
Over-Voltage Warnings	24

Over-Current Warnings	24
Reverse Polarity or Zero Volts Detection	25
Software Overview	25
Projects	25
System Tree	26
Main Screen Overview	27
Menu Bar	30
Copy, Modify, and Reuse a Previous Project	35
Properties Menu	35
View Menu	35
Utility Menu	36
Help Menu	38
Tab Screens	38
Traces Tab	38
Table Tab	39
History Tab	41
Insulation Test Tab	42
The Exported I-V Data File	43
Basis of PV Performance Predictions	49
SolSensor Irradiance Calibration	49
Irradiance Measurement	49
Prediction of PV Performance	50
Translation of Measured Values to STC	50
Measurement of I_{sc}	50
Calibration Verification	51
Software Updates	51
I-V Curve Tracer and SolSensor Firmware Updates	51
Make Measurements	52
Before You Take Field Measurements	52
Charge the Equipment	52
Make Sure to Run the Latest Software	52
Create a Project in the Software	52
Assure Adequate Irradiance for Your Measurements	52
Measurements in the Field	53
Measure the Open Circuit Voltage (V_{oc})	53
Connect the I-V Curve Tracer Test Leads	53
Launch the Software	53
Load Your Project	53
Measure Individual Strings versus Parallel Strings	53
Measure High-efficiency Modules	53
Connect the Test Leads to the PV Equipment	54
Select the First PV Circuit to be Measured	54
Make the First Measurement	54
Select the Next PV Circuit and Make Another Measurement	56
View Consistency of Data	56
Alerts	57

Data Backup.....	57
Measure Irradiance, Temperature, and Tilt.....	58
Measure Irradiance with SolSensor.....	59
SolSensor Irradiance Sensor	59
Preliminary vs. Effective Irradiance.....	59
SolSensor Precautions.....	59
Diffuse Light	60
Determine Irradiance from the Measured I-V Curve.....	60
Enter the Irradiance Manually.....	61
Measure the Backside Temperature of a PV Module with a Thermocouple.....	61
Select a Thermocouple Wire Gauge	62
Select a Thermocouple Tip	62
Measure PV Module Temperature with an Infrared Thermometer.....	63
Determine Cell Temperature from the Measured I-V Curve	63
Measure PV Module Backside Temperature with a Thermocouple	64
Interpret Measured I-V Curves.....	65
Inputs to the PV Model	65
I-V Curve Terminology.....	66
Performance Factor	66
Fill Factor	66
The Shape of a Normal I-V Curve	67
Interpret I-V Curves	68
Notches or Steps	70
Array Is Partially Shaded, or Non-uniform Soiling, or Debris is Present.....	70
PV Cells Are Damaged	72
Low Current	72
..... Uni-	
form Soiling	72
Dirt Dam	72
Module Degradation.....	72
Incorrect PV Module Is Selected for the PV Model	73
Number of PV Strings in Parallel Is Not Entered Correctly in the Model.....	73
Irradiance Changed Between Irradiance and I-V Measurements	73
Irradiance Sensor Is Not Oriented in the Plane of Array	73
Albedo Effects (Reflection).....	73
Manual Irradiance Sensor Is Not Accurate	73
Low Voltage.....	74
PV Cell Temperature Measurement Is Incorrect.....	74
One or More Bypass Diodes Are Shorted.....	74
Rounder Knee	74
Steeper Slope in Horizontal Leg.....	75

PVA-1500HE, PVA-1500T, and SolSensor-300V3

Users Manual

Tapered Shade or Dirt Dam Across All Cell Groups	76
Increased Shunting in PV Cells	76
Less Steep Slope in Vertical Leg	76
PV Wiring Has Excess Resistance	77
Electrical Connections in the Array Are Resistive	77
Series Resistance of PV Modules Has Increased	77
Troubleshoot PV Arrays	77
Translation of I-V Data to Standard Test Conditions	77
Parameter Definitions.....	78
Translation Equations	79
Maintenance	80
Clean the Product	80
Clean the SolSensor Irradiance Sensor.....	80
Product Disposal.....	80
Troubleshoot PVA Software Operation	80
Troubleshoot with Status Messages.....	80
Troubleshoot by Symptom.....	82

Introduction

This document covers the Solmetric I-V Curve Tracer kit which includes the PV-1500HE2 and PV1500T2 (I-V Curve Tracer), SolSensor-300V3 (SolSensor), and the I-V Curve Tracer application software (PVA Software or the Software).

The I-V Curve Tracer is a portable electrical test instrument that commissions and troubleshoots PV arrays. The I-V Curve Tracer measures the current-voltage (I-V) curves of PV (Photovoltaic) modules and strings and immediately compares the results to the predictions of built-in PV models. Measurement results are saved for future reference and analysis. The I-V Curve Tracer and SolSensor are controlled wirelessly by a Tablet or a Notebook PC. This wireless feature lets a user work in the immediate work area without trip hazards associated with hard-wired interconnections.

Note

Unless otherwise noted, this manual uses PC to refer to either a laptop or a tablet.

The I-V Curve Tracer makes the electrical measurement of the I-V curve, while the SolSensor simultaneously measures the irradiance, PV module temperature, and array tilt.

The I-V curve of a PV module, string, harness, or array provides a detailed description of its energy-conversion ability. The curve nominally ranges from the short circuit current (I_{sc}) at 0 V to the open circuit voltage (V_{oc}) at zero current. At the *knee* of a normal I-V curve are the maximum power current and voltage (I_{mp} , V_{mp}), the point at which the array generates the maximum electrical power at the present irradiance and temperature. These important voltages and currents are captured when the I-V curve is measured. The detailed shape of the curve between these points gives additional information about the health of the PV module, string, or array under test.

To increase the insight gained, the measured I-V curve is compared to predictions of key points with a comprehensive PV model. The model takes into account:

- the PV module specifications
- the number of modules in series and strings in parallel
- the losses in system wiring
- the irradiance in the plane of the array
- the module temperature, and array orientation

The Software has a powerful Array Navigator tool with a graphical array tree used to save and recall measurement data. The New Project Wizard guides a user through the set up of the PV model and customization of the array tree for each project.

The Software also saves insulation resistance data collected by a separate insulation resistance tester. This data is stored and managed with the same type of array tree touch interface (with a tablet) as the I-V measurement results.

Note

*Go to the Product page at www.fluke.com to download any current software updates, manual supplements, or revised manuals. Compare the posted version or revision numbers with the versions that the user has. To find the current software version, from your software, select **Help>About**. To update, download the latest version and run the installer. The Software is free. The latest software supports all the Fluke and Solmetric 1500V I-V curve tracers.*

Contact Fluke

Fluke Corporation operates worldwide. For local contact information, go to our website: www.fluke.com.

To register your product, or to view, print, or download the latest manual or manual supplement, go to our website.

+1-425-446-5500

fluke-info@fluke.com

Safety Information

General Safety Information is in the printed Safety Information document that ships with the I-V Curve Tracer and at www.fluke.com. More specific safety information is listed where applicable.

A **Warning** identifies hazardous conditions and procedures that are dangerous to the user. A **Caution** identifies conditions and procedures that can cause damage to the Product or the equipment under test.

 **Caution**

To avoid Product damage:

- **Do not expose the PVA to >1500 V or >30 A.**
- **Before you measure in a combiner box, make sure to:**
 - **Open the dc disconnect switch to electrically isolate the combiner box from other combiners and the inverter. Use a voltmeter to double check that the combiner is isolated.**
 - **Remove all string fuses except for the string(s) under test. Multiple strings can be tested in parallel if their combined current is <30 A.**
 - **Electrically isolate the string(s) under test when you measure at an inverter.**
 - **Observe the 30 A limit when you measure strings in parallel in harness circuits.**
 - **Limit strings of high-efficiency modules to <10 A when you use the PVA 1500V4/T.**

Specifications

Complete Product specifications are available at www.fluke.com. Safety specifications are in the Safety Information that shipped with the product.

PC Minimum System Requirements

Systems that do not meet the subsequent requirements might not operate as anticipated. A Microsoft Windows laptop or touch sensitive tablet works well. Tablets tend to be more rugged than laptops in the field.

Fluke recommends:

- A touchscreen device for best productivity
- A laptop that can be used as a tablet
- A screen with good contrast in bright sun
- Anti-glare screen surface
- Good view angle so multiple people can see the screen

The PC should have:

- Microsoft Windows 11,10, 8, or 7 (32-bit or 64-bit versions)
- Wi-Fi
- Display resolution of 1024 X 600 (minimum)

- Processor Speed of >1 GHz (1.5 GHz recommended). Fluke recommends a Windows Experience Index (Processor component) of 2.3 or greater. This value is available from the PC Control Panel under Performance Information and Tools.
- RAM: 4 GB minimum (8 GB recommended)
- Available disc space: 100 Mb or more

Equipment

The I-V Curve Tracer ships with:

Curve Tracer Equipment

- The I-V Curve Tracer - in its soft case, with a complete set of Fluke-provided gear either in its accessory pouch or transit case. Check for PVA test leads and PV connector tools.
- Soft case
- AC wall plug charger
- 1500 V rated test leads for PV-1500HE2: banana jack to MC-4 and banana jack to alligator clips. For other PVA models: MC-4 to alligator clips
- MC-4 connector tool
- Printed *Safety Information*
- Printed *Getting Started*
- Transit case (included with PVA-1500HE2 only)

SolSensor Equipment

- SolSensor unit
- K-type thermocouple temperature sensors (2)
- Soft case (unless I-V Curve Tracer kit was purchased with the transit case option)
- Module frame clamp
- AC wall adapter with dual USB-A outputs for charging the IV Unit and the SolSensor
- Adhesive discs for thermocouple attachment (50). Discs of high-temperature tape to attach the tip of the thermocouple to the module backside
- SolSensor tool lanyard to secure SolSensor to the racking
- Supplies to clean the irradiance sensor (micro-fiber cloth and distilled water spray)

The main parts of the I-V Curve Tracer Kit are shown in [Table 1](#) and [Table 2](#).

Table 1. SolSensor

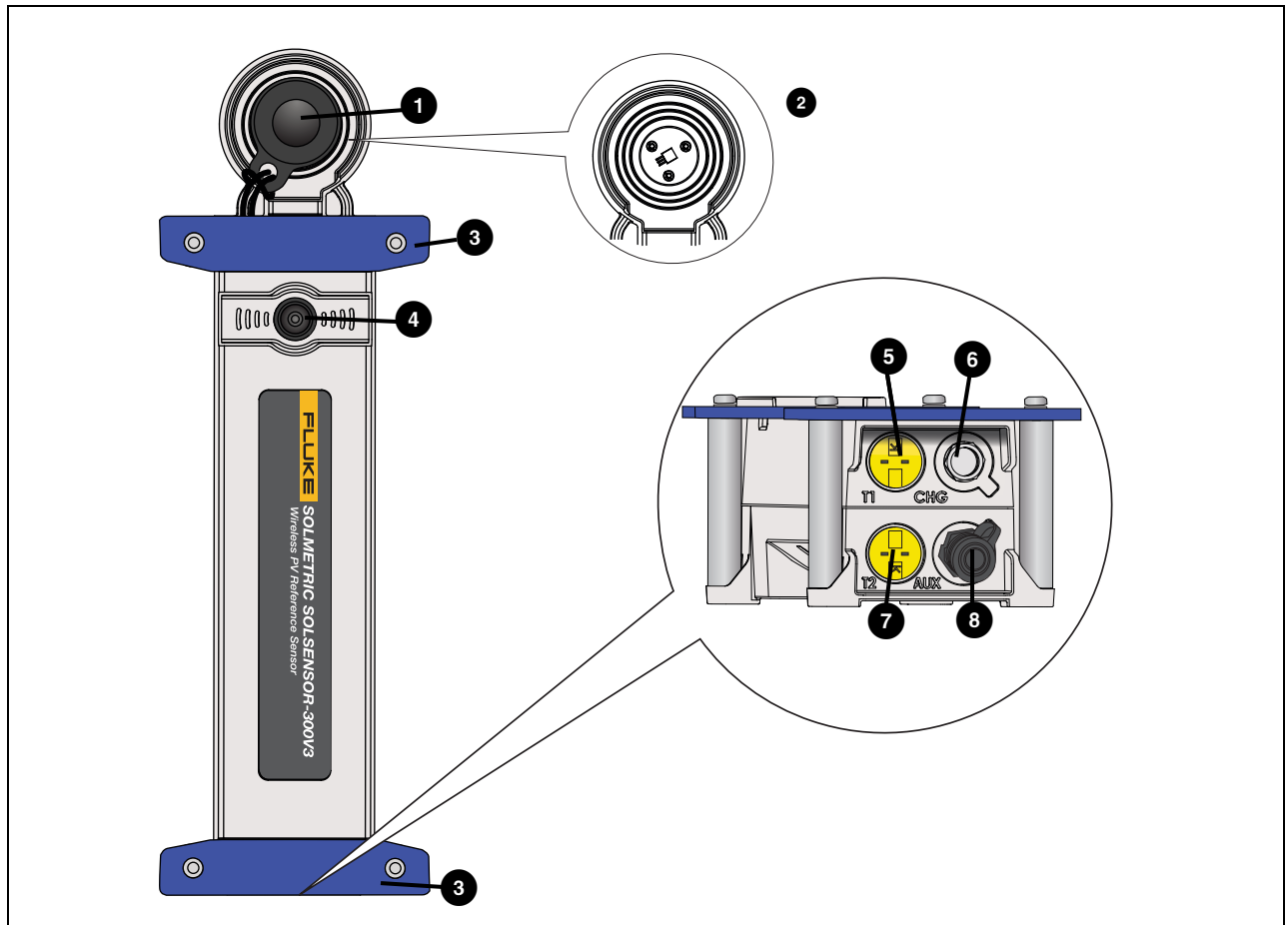

Item	Description
1	Irradiance Sensor Cover
2	Irradiance Sensor
3	Ears
4	LED Power Button
5	T1- Thermocouple 1 input
6	Battery charge input
7	T2- Thermocouple 2 input
8	Auxiliary input

Table 2. I-V Curve Tracers

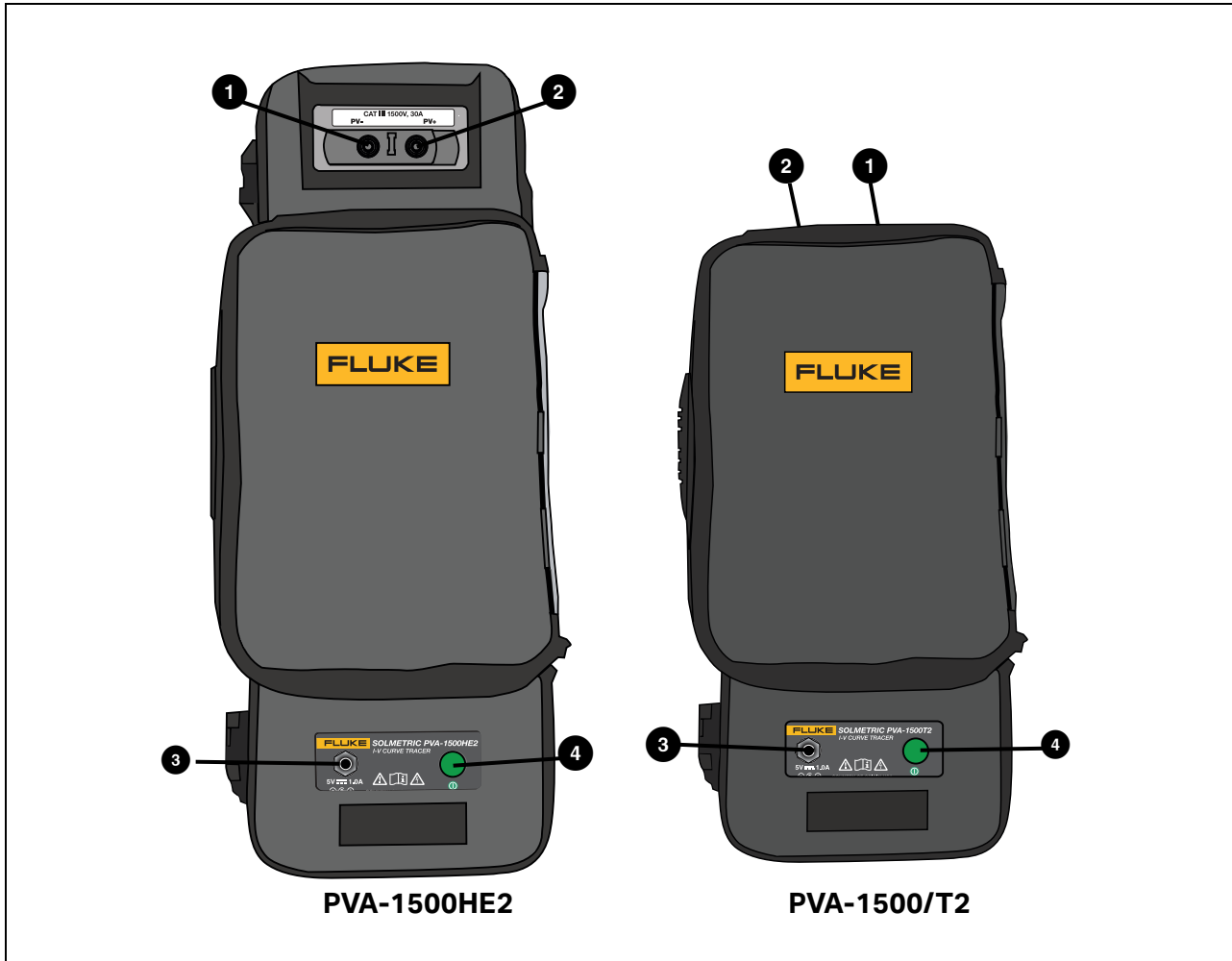

Item	Description
1	Negative Input
2	Positive Input
3	Battery Charger Input
4	LED Power Button

System Controls and Settings

Use the LED button on the I-V Curve Tracer and SolSensor, see [Figure 1](#), to enable, pause, and reset the I-V devices. The LED indicates various operational states of the devices and the status of the wireless network. See [Table 3](#).

Table 3. Operational States of the I-V Curve Tracer and SolSensor LED Button

I-V Curve Tracer	SolSensor	LED Behavior	Device State	Button Behavior
X	X	Off	Off	Push 1x to turn on
X	-	Slow flash	Paused. I-V Curve Tracer turns off automatically in 15 minutes to conserve the battery.	Push once to enable measurements or 3x to turn off the I-V Curve Tracer.
X	X	Flash	No Wi-Fi or connection to the Software.	Push 3x to turn off.
X	X	Rapid Flash	Starting up or Error (if continuous).	-
X	X	Steady on	Connected to Software, measurements enabled.	Push once to pause (I-V Unit) or 3x to turn off.
X	X	-	Any state	Push 3x to turn off.
X	X	Five flashes, pause, repeat	Device attempts to pair.	To pair devices: push 5x in rapid succession.
X	X	Slow Flash or Steady on when plugged in and no connection to Software.	Flash indicates a charging battery. Steady on indicates battery is fully charged.	-

When you push the LED button once to turn on the I-V Curve Tracer or SolSensor, the LED flashes rapidly as it starts, then flashes slower until the device connects with the PC Wi-Fi and Software. Once it connects to the Software, the LED is steady on.

Before you connect the I-V Curve Tracer test leads to the PV circuit, push the LED button on the I-V unit once to pause measurements. This prevents an accidental trigger of a measurement as you make connections. While in this paused state, the LED flashes with long pauses to show that the I-V Curve Tracer is on and paused.

After connections are made to the test leads, push the button once to enable the I-V Curve Tracer to make measurements under control of the Software. The LED stays steadily lit, to indicate that the I-V Curve Tracer is ready to take measurements.

If the network connection is lost, the LED flashes to indicate the lost connection to the Software.

Note

If the I-V Curve Tracer or SolSensor is plugged in to the AC charge adapter and connected to the Software, the LED button indicates the connected/disconnected state (solid or flashing LED), not the charging/charged state.

The I-V Curve Tracer and SolSensor are uniquely paired at the factory. If they need to be paired again:

1. Push the I-V Curve Tracer LED button five times in rapid succession to initiate re-pairing.
2. Wait until the I-V Curve Tracer LED button begins to flash in groups of five, then push the SolSensor LED button five times in rapid succession. Both LEDs flash in groups of five until pairing occurs.

When necessary to reset either the I-V Curve Tracer or the SolSensor, hold the LED button down for at least 6 seconds and release.

Power Up the I-V Curve Tracer

To power up the I-V Curve Tracer, push the power button once, see [Figure 1](#).

If a network is not established within 15 minutes, the I-V Curve Tracer turns off to conserve the battery. In normal use, the I-V Curve Tracer does not go into sleep mode when the LED is steady on. However, if placed into the Pause mode, the I-V Curve Tracer enters sleep mode 15 minutes after placed in Pause. To use Pause, push the power button (in Pause mode the LED flashes briefly every 3 seconds).

Test Leads and Clips

The included test leads and clips are specifically provided for use with the Product. These leads and clips are specially rated for use at voltages up to 1500 V and 30A dc. See [Table 4](#).

Table 4. Test Leads

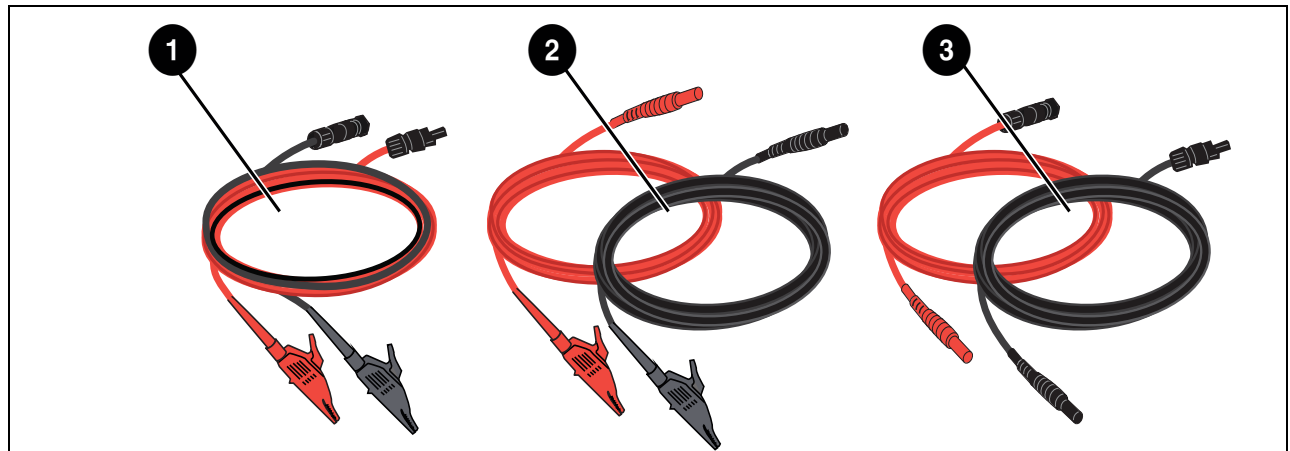

Number	Description
1	PVA-1500S/V2/V3/V4/T MC-4 to alligator clip
2	PVA-1500HE2 banana jack to alligator clip
3	banana jack to gold-plated MC-4

Operating temperature and humidity of the test leads and clips are more narrowly specified than the PVA-1500HE2 and SolSensor. For details see PVA-1500 Test Lead and Clip Specifications. See [Specifications](#).

Warning

To prevent possible electrical shock, fire, personal injury, or death:

- Read all safety information before you use the test leads.
- Only use the PVA-1500 series test leads and clips on the Photovoltaic (PV) solar modules and arrays.
- Only use with isolated (ungrounded) PV circuits.
- For protection from hot surfaces, do not remove the enclosure from the canvas case. The I-V Curve Tracer dissipates stored energy in the form of heat in normal operation.
- Remove circuit power before you connect the I-V Curve Tracer to the circuit. For example, when you test in a PV combiner box, open the disconnect switch and lift all the fuses before you attach the test leads and clips.
- Do not handle the test leads and clips while they are energized by the source circuit.

Cover the Irradiance Sensor

When not in use, always keep the irradiance sensor (see [Figure 1](#)) covered with the supplied black rubber cover. Remove the cover after you mount SolSensor in the plane of the array, and replace the cover again before you move SolSensor to another location.

The white acrylic eye of the irradiance sensor is a precision optical element which must be kept in *like new* condition to assure accurate measurements. It is easily damaged by impact or abrasion, and its accuracy is also compromised by soiling. Keep the cover on when not in use.

Installation

This section describes the I-V Curve Tracer installation procedure.

Caution

If either the I-V Curve Tracer or SolSensor are dropped, Fluke recommends that the Product(s) be sent back to Fluke for examination.

Installation Procedure

Hardware Installation

Before operation, make sure the I-V Curve Tracer and SolSensor batteries are fully charged. Refer to [Charge the Battery](#).

Software Installation

To install the Software:

1. Download the Software from www.fluke.com.
2. After the download, if the software welcome screen does not automatically open, run the installer.
3. Follow the on-screen instructions to install the Software
4. During installation, if a Windows update dialog appears, connect the PC to the Internet to download any required Windows prerequisites.
5. After you start the installation and/or install the Windows updates, the installation location screen appears. The default location is provided.
6. When installation completes, the final setup wizard screen appears. If the **Run I-V Curve Tracer** box is selected, click **Finish** to launch the Software. Alternately, click **Finish** and then double-click on the shortcut icon on the desktop to start the Software.

When the initialization completes and the Software launches, the Software shows the main screen. See [Table 7](#).

At installation, the Software creates the directory structure in the **Documents** directory.

Update the PV Equipment Databases

If connected to the Internet when the Software starts, the Software checks if the updated PV module equipment databases are available from Fluke.

Charge the Battery

Charge the I-V Curve Tracer Battery

Note

The I-V Curve Tracer battery is not removable.

To recharge the battery:

1. Connect the battery charger to the connector on the I-V Curve Tracer, see [Figure 1](#).
2. Plug the charger into an ac outlet and plug the USB end of the charger cable into the ac charger adapter.

The LED button flashes to indicate that the I-V Curve Tracer battery is charging. The LED glows solid when the battery is completely charged.

Figure 1. I-V Curve Tracer Battery Charger Connector (PVA-1500HE2 Shown)

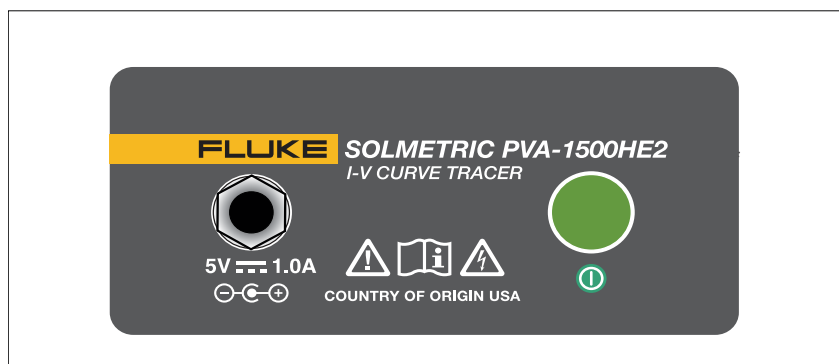

The battery can take 6 hours to charge. Charge the battery each night before use in the field.

The Software interface warns when the battery level is low. To manually check the battery voltage level, click the Status area (above the **Measure Now** button) on the screen or select **Battery Level** from the **Utility** menu. Make sure the I-V Curve Tracer has been on and connected to the software for at least 30 seconds before the battery level check.

Charge SolSensor

Note

The SolSensor battery is not removable.

To recharge the battery:

1. Attach the battery charger cable to the charge connector, see [Figure 2](#).
2. Plug the ac charger adapter into an ac outlet and plug the USB end of the charger cable into the ac charger adapter.

Figure 2. Connected SolSensor Charger

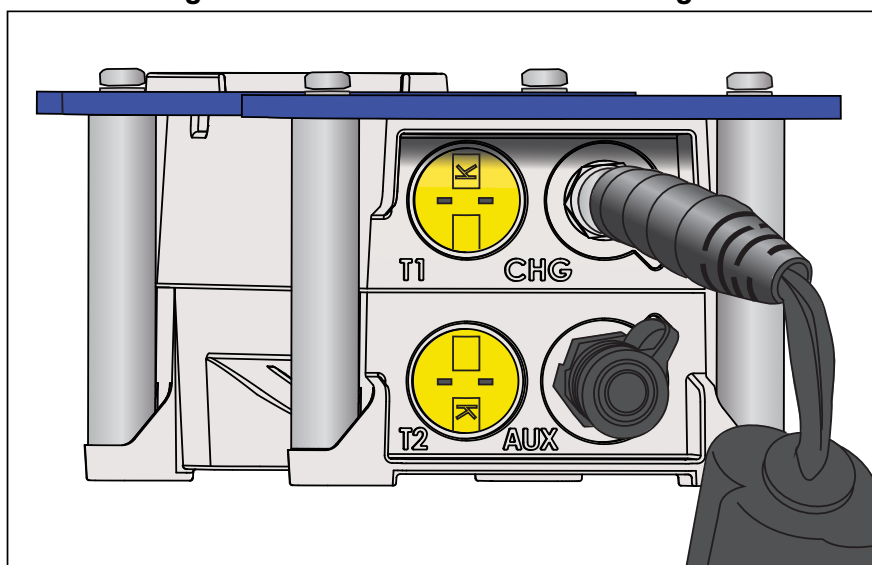

The battery can take 6 hours to charge. Charge the battery each night before use in the field. As SolSensor charges, the LED button flashes. When the battery charge completes, the LED button glows solid.

Note

If SolSensor is plugged in and connected to the Software, the LED button indicates the connected state (solid LED), not the charging/charged state.

To check the battery voltage level, click the Status area (above the **Measure Now** button) in the Software after an I-V measurement or select **Battery Level** in the **Utility** menu.

The Wireless Network

Communication between the PC and the I-V Curve Tracer is by conventional Wi-Fi. When the I-V Curve Tracer is on, the I-V Curve Tracer creates a hotspot. Locate that hotspot in the PC network list and connect to that network. The SSID (hotspot name) has the format *pva1500_nnnnnn* where nnnnnn is the unique identifier of the I-V Curve Tracer.

SolSensor automatically links to the I-V Curve Tracer when both are turned on. All communications between the PC and SolSensor are relayed through the I-V Curve Tracer.

To see a diagram of the wireless network, select the network icon at the lower left of any screen in the Software ().

The I-V Curve Tracer and SolSensor come from the factory paired to each other. A SolSensor can only be paired to one unique I-V Curve Tracer at a time. To pair a different I-V Curve Tracer, see [Set Up the I-V Curve Tracer](#). When a SolSensor is paired to a I-V Curve Tracer, it forgets any previous pairing.

Because the PC connects with the I-V Curve Tracer Wi-Fi, the built-in Wi-Fi interface is not available to simultaneously connect to other networks or devices. To avoid this limitation, add a USB Wi-Fi adapter as the second network interface.

When you use the I-V Curve Tracer, and the Wi-Fi link to the I-V Curve Tracer hotspot temporarily drops, the PC attempts to automatically connect to another network in your list that is set to **connect automatically**. To avoid this, in the network list on the PC, check the **connect automatically** box for the I-V Curve Tracer hotspot, and uncheck **connect automatically** for other networks.

Set Up and Use the I-V Curve Tracer and SolSensor

Set Up the I-V Curve Tracer

To set up the I-V Curve Tracer:

1. Put the I-V Curve Tracer near the PV circuits under test.
2. Connect alligator clip leads, if necessary. Use only clip leads supplied with the I-V Curve Tracer and rated for at least the maximum current and voltage of the I-V Curve Tracer.
3. You can make extension cables if the I-V Curve Tracer cannot be located near the circuit under test. When extension cables longer than 10 ft (one-way) are added between the circuit under test and the I-V Curve Tracer, route the cables parallel next to each other to minimize the inductance they add to the circuit.

Set Up SolSensor

Caution

To avoid damage to SolSensor:

- Cover the irradiance sensor with the protective cap whenever it is not mounted and in use. SolSensor contains a sensitive irradiance measurement device that can be damaged by impact or abrasion. To preserve sensor accuracy, do not soil the irradiance sensor. See [Clean the SolSensor Irradiance Sensor](#).

Figure 3 shows SolSensor mounted on the frame of a PV module.

Figure 3. SolSensor Mounted on Frame of a PV Module

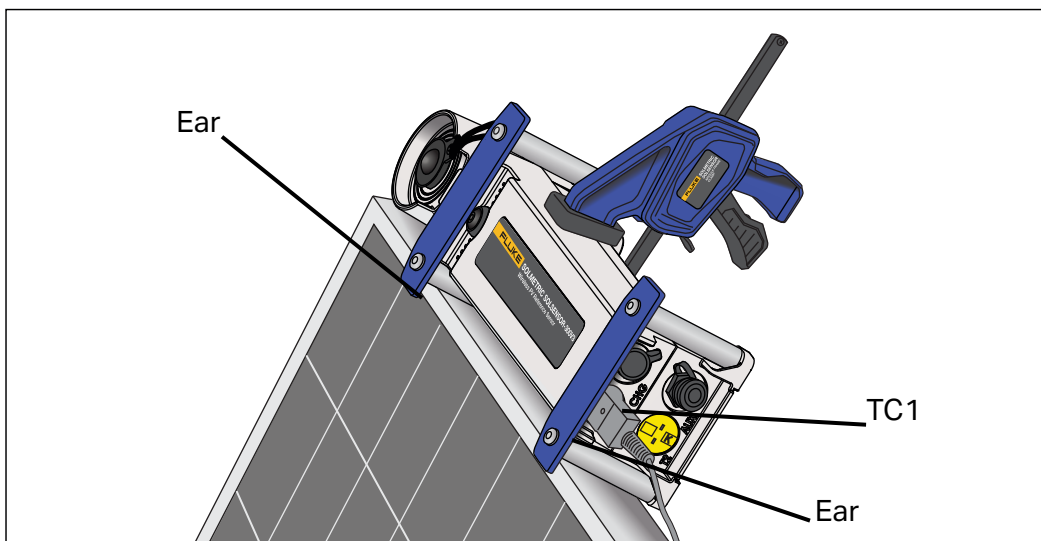

Mount SolSensor to a PV Module Frame

Figure 4 shows SolSensor attached to a PV module with the Module Frame Clamp and secured with the tool lanyard.

Note

If you mount SolSensor along the upper horizontal edge of the module, you can achieve better irradiance accuracy earlier and later in the day.

Figure 4. SolSensor Tool Lanyard Secured to a Racking Member

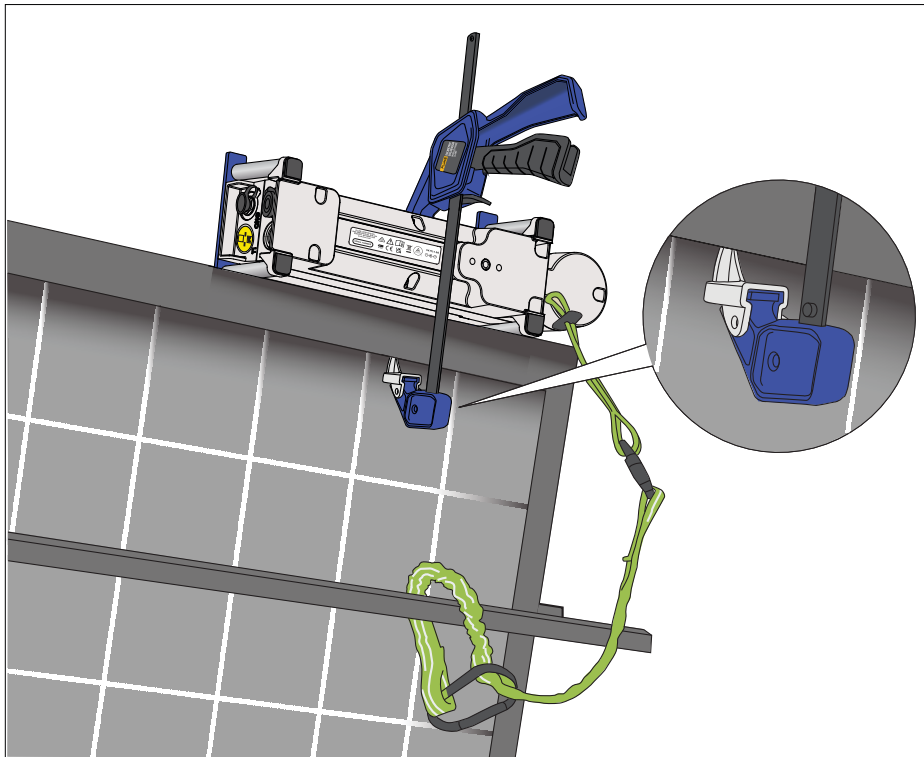

To mount SolSensor:

1. Place SolSensor against the top horizontal leg of the module frame, with its metal posts and ears seated against the frame surfaces, as shown in [Figure 3](#).
2. As you hold SolSensor in that position, slip the tip of the Module Frame Clamp inside the frame of the module. Seat the tip of the clamp on the flat inner surface of the frame as shown in the inset of [Figure 4](#) and not on a shelf or ridge from which it could slip and allow SolSensor to come loose. Make sure to not impact or scratch the backside of the module with the foot of the clamp.
3. Squeeze the clamp mechanism until SolSensor is firmly held against the side of the module frame.
4. Inspect the mount and make sure that the posts and ears are in contact with the upper edge of the module frame. If there is space under one or both of the ears, the irradiance sensor will not be in the plane of the array as necessary. Loosen the clamp slightly, reposition SolSensor, and re-tighten the clamp. If the SolSensor is mounted high in the air (for example, on a carport array), Fluke recommends the use of the lanyard as a back up in case the SolSensor comes loose from the clamp. Attach the tool lanyard to an eyelet on SolSensor. Then loop the lanyard around a racking member and clip it back on itself, as shown in [Figure 4](#).

5. Unwind a thermocouple and straighten the lead. Avoid kinks in the lead. Connect the thermocouple to SolSensor. Insert the yellow plug of the thermocouple wire into the upper left yellow receptacle labeled TC1, see [Figure 3](#).
6. Straighten the last few inches of the thermocouple lead. The tiny ball at the end is where temperature is measured.
7. Tape the tip of the thermocouple into firm contact with the backside of the module, far enough under the module to avoid the cooler outer edges. When you test single, free-standing modules, attach the thermocouple tip as shown in [Figure 5](#). For accurate temperature measurements, use a wide piece of high temperature polyester tape. Fluke recommends the use of the adhesive discs provided with the Product. Other types of tape sag at high temperatures which allow the tip of the thermocouple to pull away from the backsheet of the module. Use firm pressure to roll the tape over the thermocouple tip to force the tip into solid contact with the module backside.

A second thermocouple can be added with the TC2 input on the SolSensor. When you use two thermocouples, Fluke recommends they be attached in different locations on the module or on a second module.

Figure 5. Locate the Thermocouple Tip on a Single Free-Standing Module

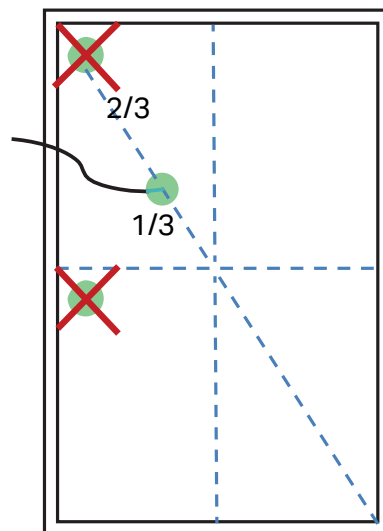

8. Remove the protective cover from the SolSensor irradiance sensor.
9. Push the LED button to turn on SolSensor. The LED flashes as it attempts wireless connection, and glows steadily when the connection is made, see [Figure 1](#). SolSensor links to the I-V Curve Tracer, which relays its communications with the PC.

Optimize Wireless Transmission Range

Follow these practices for best SolSensor transmission range.

- Locate SolSensor for best line-of-sight to the I-V Curve Tracer, which acts as a relay station between SolSensor and the PC.
- Avoid locations where the signal must transmit through buildings or trucks, or through many rows of PV modules and racking.
- Avoid placement of SolSensor directly on a metal surface such as a metal roof or HVAC box, as this reduces range. If you mount SolSensor on the end of a torque tube of a single-axis tracker, it may give a better range if you first mount SolSensor to a short bar, and then mount the bar to the torque tube.

Transmission range can sometimes be increased when you locate SolSensor on the top frame edge of a top-row module, or near the end of an array where there is better line of sight to where the I-V Curve Tracer is set up.

If it is not possible to achieve the necessary transmission range with the above methods, mount SolSensor on a tripod and orient it to the correct azimuth and tilt. Choose a location that has sky exposure similar to the array itself.

Mount SolSensor on a Tripod

For greater flexibility and for potentially better wireless range, mount SolSensor to a tripod. This is also useful when it is not feasible to access the array.

Use this equipment to deploy SolSensor on a tripod (contact Fluke for specific equipment recommendations):

- Sturdy tripod
- Tripod level indicator

This is typically a disc with a bubble level that mounts between the tripod and the rest of the fittings described here. Some tripods have a built-in level indicator.

Note

Level indicators vary widely in their sensitivity and accuracy.

- Tripod leveling head - Quickly creates a level mounting surface, without the need to adjust the tripod legs.
- Panning unit -Rotates about the vertical axis, and lets you adjust the azimuth of SolSensor independent of the tilt.

2. Consider these factors when you choose a tripod location:
 - Location should have an open view of the sky, similar to the array itself. Avoid locations where trees or structures obscure parts of the sky, especially on cloudy days where diffuse light makes up a significant part of total irradiance. Avoid locations that have substantial albedo effects (reflections).
 - Location should have good line of sight to the combiner boxes or other locations where the PC is to be used.
 - To use thermocouples to measure the backside of the module temperature, locate the tripod close enough to a sub-array that you can attach the tip of the thermocouple well under the modules, away from the cooler outer edges of the array. A thermocouple extension cable can be useful. Contact Fluke for recommendations.
3. Fully spread the tripod legs and seat them firmly.
4. Connect the thermocouple wire to SolSensor and attach the thermocouple tip to the backside of a PV module. Do not attach the thermocouple near the edges of the module, which are cooler. Alternatively, omit the thermocouple(s) and set the software to derive the cell temperature from the I-V curve.
5. If averaging the readings of two thermocouples, also deploy the second thermocouple. If a second thermocouple is used, but not attached to a module (for example, if it is used to measure the ambient temperature) then do not use SmartTemp or average as the temperature method.
6. Adjust the leveling unit to center the bubble, and lock the leveling unit.
7. Rotate the panning unit to orient SolSensor to the same azimuth (compass heading) as the array under test, then lock the panning unit. Be sure to adjust your compass for the local magnetic declination. A magnetic declination calculator is available at <http://www.ngdc.noaa.gov/geomag-web/?id=declinationForm1d>. To avoid distortion from earth's magnetic field by components in SolSensor or the tripod mounting hardware, separate the compass horizontally from SolSensor. Insert a non-ferrous rectangular spacer.
8. Rotate the tilt unit until the tilt angle indicated in the Software matches the actual tilt of the PV array, and then lock the tilt unit.

Connect to the Solar PV Equipment

Installed PV systems vary in design and construction. Therefore, the guidance provided in this section is general in nature, and it is critical that you apply techniques and precautions appropriate to the circumstances. Follow best PV/electrical safety precautions.

Note

The subsequent procedure, while important, does not cover all situations. Assess the potential dangers of each PV system, and take appropriate precautions.

To connect to the Solar PV equipment:

1. Isolate the PV module string to be tested (test string) from the inverter and from other strings in the array. To make the measurement at a fused dc combiner box, isolate the combiner box by means of a dc disconnect switch, and pull the fuses to isolate the PV strings from one another.
2. To make the measurement at a string inverter if the strings run directly to the inverter, pull the series fuses to isolate the strings from one another and from the inverter input circuits.
3. Push the button on the I-V Curve Tracer to disable the I-V sweep.

⚠ ⚠ Warning

To prevent possible electrical shock, fire, personal injury, or death, know that PV circuits continue to present danger of electrical shock while the I-V Curve Tracer is paused.

4. Use safe operation procedures to connect the PV leads of the I-V Curve Tracer to the PV source to be measured. Make the connection at the PV module, at the ends of home-run cables, at a combiner box at the inverter. Connect the PVA test leads to the string to be measured. In some cases, you can attach the alligator clips to the bus bars in a combiner box (see [Figure 7](#)) or to the fuse clips in an inverter.

Figure 7. I-V Curve Tracer Test Leads Clipped to the Buss Bars of a PV Combiner Box

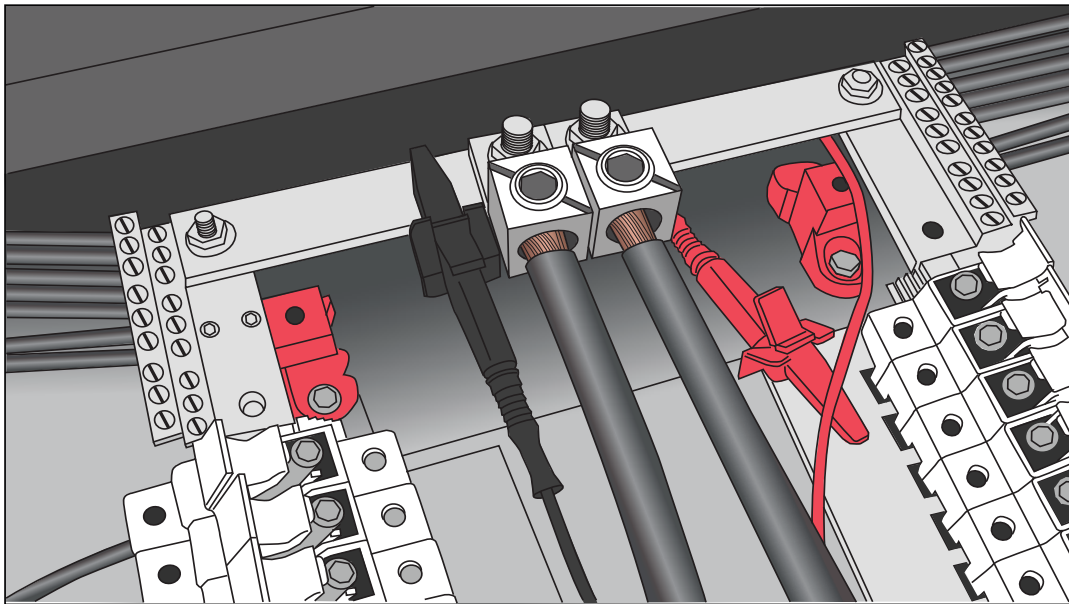

5. If the distance between the circuit under test and I-V Curve Tracer requires the use of extension cables, use a properly-rated PV cable for the maximum system voltage, with correctly installed connectors. Select a wire gauge that results in a suitably small voltage drop.

When extension cables longer than 10 ft (one-way) are added between the circuit under test and the I-V Curve Tracer, widely space the cables to minimize the inductance they add to the circuit.

6. If you connect at a fused combiner box, for best results Fluke recommends you insert only one string at a time. Some combiner boxes have one fuse per string while others have two fuses per string (one on the positive side and another on the negative side). If you test a combiner with two fuses per string, then leave all of the fuses on the negative side inserted and insert one fuse on the positive side at a time. Multiple strings can be measured at the same time in parallel as long as the total current does not exceed the rating of the I-V Curve Tracer.
7. Push the button on the I-V Curve Tracer to un-pause and enable the I-V sweep.

I-V Measurements

The I-V Curve Tracer measures an I-V curve each time you click the **Measure Now** button in the Software. I-V data transmits to the PC shortly after the I-V Curve Tracer takes each I-V sweep. Data is not stored in the I-V Curve Tracer itself after transmission to the PC. The V_{oc} measurement is done the instant before the I-V sweep begins.

Sweep Disabled

PV current stops automatically at the end of each I-V measurement. However, before you connect or disconnect test leads or cables, push the I-V Curve Tracer power button to pause the measurement sequence. Manually disabling the I-V Curve Tracer in this way ensures that the I-V Curve Tracer does not make an unexpected I-V measurement. When ready to take another measurement, push the power button again.



To prevent possible electrical shock, fire, personal injury, do not connect or disconnect the PV leads if the LED on the I-V Curve Tracer is solid on.

Over-Temperature Protection

Built-in safeguards prevent I-V Curve Tracer operation at potentially damaging internal temperatures.

The I-V Curve Tracer absorbs energy with each measurement, and across a series of measurements the internal temperature of the I-V Curve Tracer gradually increases. Some of this accumulated heat is shed between measurements and as the equipment is moved around the site between measurement sessions. If, on average, the heat gain exceeds the heat loss and the internal temperature continues to rise, the internal temperature sensor triggers. When that happens, the I-V Curve Tracer shuts down to cool the instrument, and the Software posts the **Disabled** message in the Status indicator, directly above the **Measure Now** button.

Caution

To avoid I-V Curve Tracer damage, locate the I-V Curve Tracer in the shade to reduce the likelihood of thermal shutdown. If possible, do not place the I-V Curve Tracer on an asphalt driveway, solar panel, or roof in direct sunlight.

Sweep-to-Sweep Delay and Thermal Capacity

To manage the internal temperature of the I-V Curve Tracer, there is a sweep-to-sweep delay that limits how quickly a subsequent I-V sweep can be made. The delay varies and depends on the V_{oc} measured as shown in [Table 5](#).

Table 5. Sweep-to-Sweep Delay

V_{oc}	Sweep-to-Sweep Delay
≤200 V	6 seconds
201 V to 1000 V	6 seconds
1001 V to 1350 V	8 seconds
>1350 V	11 seconds

The thermal capacity of the I-V Curve Tracer is the number of I-V measurements that can be made before the maximum allowable internal temperature is reached and an extended cool off period is required. Thermal capacity decreases with higher V_{oc} , higher outdoor ambient temperatures, and shorter wait time between measurements. For a reference PV system with 16 strings per combiner box and string V_{oc} of 1300 V, if you measure the 16 strings one after another followed by 5 minutes of no measurements (for example, while you move to the next combiner box), then the thermal capacity is as shown in [Table 6](#) for two different Sweep-to-Sweep Delay scenarios and two different ambient temperatures.

Table 6. Thermal Capacity (Number of I-V Measurements Before Extended Cool-Down)

Sweep-to-Sweep Delay	# Measurements Before Thermal Shutdown
18 seconds	unlimited (77 °F ambient)
	550 (113 °F ambient)
9 seconds	unlimited (77 °F ambient)
	330 (113 °F ambient)

After the I-V Curve Tracer reaches the thermal capacity, a message appears and further measurements are not allowed. Every minute of cooling (for example, no measurements) increases the number of subsequent measurements allowed before thermal capacity is reached again. Keep the I-V Curve Tracer out of the sun and/or move it to an air conditioned environment to help increase the recovery rate.

 **Warning**

For protection from hot surfaces, do not remove the enclosure from the canvas case. The Product dissipates stored energy in the form of heat in normal operation.

High-Temperature Condition Operation

The most demanding thermal conditions for the I-V Curve Tracer are:

- Hot day
- No wind
- No shade
- High open circuit voltage
- I-V sweeps taken in rapid sequence

If these conditions are expected, plan ahead to minimize temperature rise in the I-V Curve Tracer. Shade the I-V Curve Tracer from direct sunlight, elevate it above hot surfaces, and allow more time between I-V sweeps.

Over-Voltage Warnings

Over-voltage Condition

Caution

To prevent I-V Curve Tracer damage, do not let the open-circuit voltage of the PV source under test exceed the specified maximum dc input voltage of the I-V Curve Tracer. The Product can be damaged and require factory repairs. Over-voltage can occur if the PV system dc voltage is higher than expected or two strings are accidentally wired in series.

If a PV voltage >1525 V is detected, an over-voltage warning shows in the Software. Reduce the PV voltage before you continue to make measurements. If a PV voltage >1550 V is detected, the I-V Curve Tracer internally disables itself to prevent further measurements and a warning is posted to return the unit to Fluke for inspection and repair of possible internal damage.

Over-Current Warnings

Caution

To prevent I-V Curve Tracer damage, do not expose the I-V Curve Tracer to current in excess of its specified dc input current. Damage may occur to the I-V Curve Tracer and require a return to the factory for repair. A warning message shows when excess current is applied to the unit.

Over-current can occur when:

- Too many strings in parallel are measured.
- When you measure strings that are still electrically connected to the rest of the array or the inverter (for example, when the combiner box dc disconnect is not opened).
- When you use a PVA-1500T2 and you measure a string of high efficiency (≥ 19 %) PV modules with a current >10 A.

High-efficiency modules produce a short but intense pulse of current at the start of every I-V curve measurement. PVA-1500HE2 tolerates this in-rush current for strings of high-efficiency modules with I_{sc} up to 30 A, however the PVA-1500T2 is limited to strings of high-efficiency modules with $I_{sc} \leq 10$ A. See [Measure High-efficiency Modules](#).

Reverse Polarity or Zero Volts Detection

If the I-V Curve Tracer detects a voltage < -0.5 V, the Software posts the **Negative Voltage Detected** warning, an internal-protection circuit prevents internal damage, and no I-V measurement occurs. It is likely that the I-V Curve Tracer is connected with the wrong polarity across a circuit.

If the I-V Curve Tracer measures a voltage between -0.5 V and 0.5 V the Software posts the **0 volts detected** warning and no I-V measurement occurs. It is likely that the I-V Curve Tracer is not connected to the circuit, the circuit has an open, or for some other reason, the circuit has close to 0 V.

Software Overview

Projects

The PVA Software stores all setup information and measurement results in a specialized file type called a Project file. The Software guides you through steps to create a Project for a particular array.

All PV modules within a Project must be of the same type and must be mounted at the same azimuth. Often a site has multiple PV arrays with a mix of different modules and azimuths. To accommodate these differences, create a separate Project for each case. To save time, copy and paste your first Project file, rename it, and edit only the features that are different.

The Software has a special feature to measure the performance of strings in horizontal single-axis tracking systems. The Software can automatically *flip*, at solar noon, from a morning azimuth to an afternoon azimuth. SolSensor reports the tilt with each measurement.

Note

Consider the creation of multiple Projects to preserve software responsiveness for large PV sites. For example, in a 50 MW project, create a separate Project for each pad or each inverter. This improves the speed of the Data Analysis Tool used to analyze your data.

Note

Make sure that the PC is set to the correct date and time, and that the time zone and daylight savings setting are correct. The Software uses these parameters to calculate the position of the sun at the exact moment of the I-V curve measurement. This allows the Software to calculate the angle of incidence of the direct sunlight and use that information to optimize the accuracy of the irradiance sensor and the PV model. Errors in these settings introduce errors in the effective irradiance measurement and in the predicted performance of the PV modules under test and, as a result, will also cause errors in the Performance Factor (measured maximum power / predicted maximum power). Verifying the correct settings is especially important if you travel between time zones with your equipment.

I-V measurements are automatically *stamped* with the date and time at the instant of the measurement.

If the PC is connected to the Internet, each time you open the New Project Wizard, the Software checks a web time server for the correct Universal Time and adjusts the PC clock as needed. Choose the time zone and daylight savings setting.

All dates and times associated with the saved measurement data are preserved even if the Project is subsequently opened in another time zone.

System Tree

When you create a new project, you are walked through a process of creating a tree representation of the system being measured. This is called the System Tree. After each I-V curve measurement is made, the Software shows the System Tree, and you will touch or click the tree to tell the Software where you took the measurement in the array. This allows the PV model to retrieve wiring characteristics and other details that are unique to that location, and tells the Software where to save the measurement result. The predictive model points (I_{sc} , P_{max} , and V_{oc}) are shown on the I-V curve graph only after you have identified the location of the measurement.

Main Screen Overview

The Software is fully touch-enabled. The main screen is shown with the Traces tab selected in Table 7.

Table 7. Software Main Screen

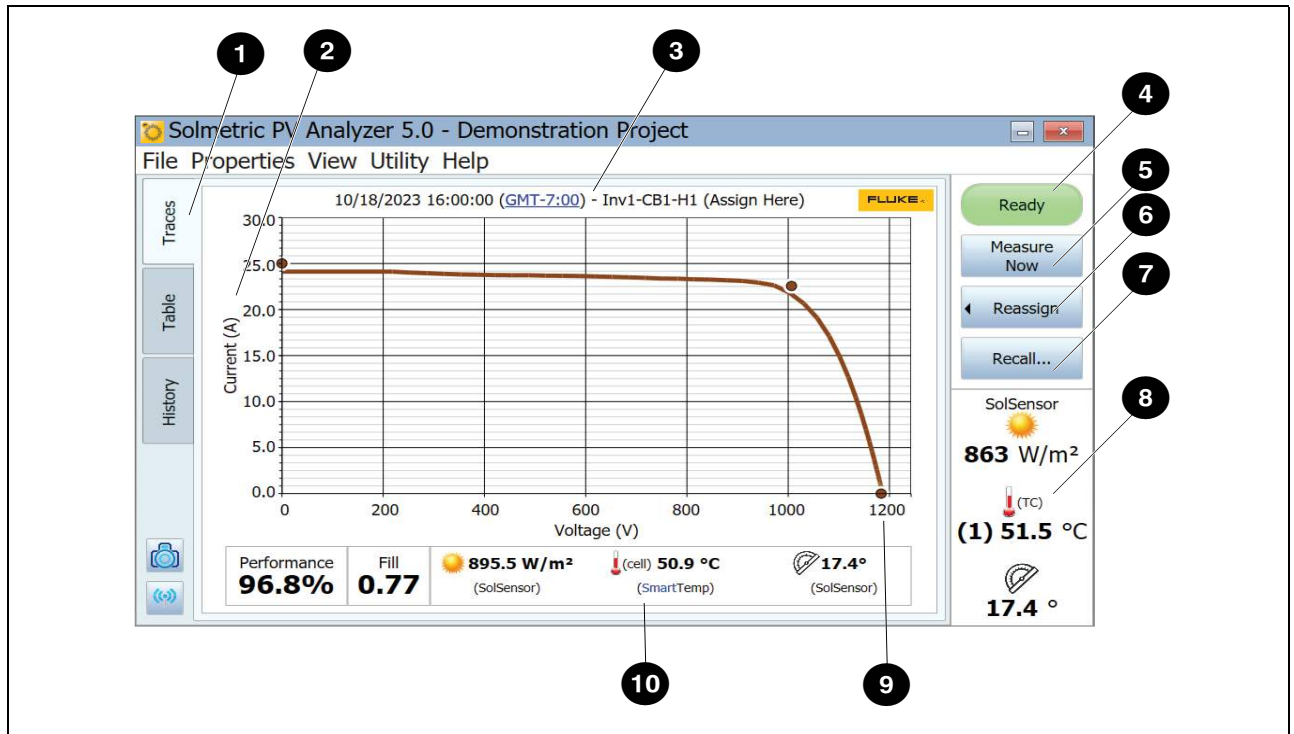

Item	Description
1	The Tabs provide different ways to view the data.
2	Current (A) - Current scale along the vertical axis on the left of the graph.
3	<p>Measurement ID - The label above the graph identifies the displayed I-V trace. If you have not assigned or saved the trace, the ID shows only the date and time at which the measurement was taken.</p> <p>If you have assigned the trace to a location in the System Tree but not yet saved it, the ID shows the date, time, and location in the System Tree and indicates that the data has not been saved.</p> <p>If you have assigned and saved the trace, the ID shows the date, time, and location in the System Tree.</p> <p>Also shown in the measurement ID is a link that shows the time offset from GMT. Click on the link to check the time zone.</p>

Table 7. Software Main Screen (cont.)

Item	Description
4	<p>Status Indicator - The status indicator in the upper right of the Software screen shows the various messages below. Click on the status indicator to see more information about the active status.</p> <ul style="list-style-type: none"> • Ready - Indicates that the I-V Unit is ready to take a fresh I-V measurement. • Searching for I-V Unit - Indicates that the Software is trying to connect to the I-V Unit. This status should change to Ready within seconds after you connect your PC to the I-V Curve Tracer Wi-Fi hot spot. If there is a problem, it is typically because they are out of wireless range of one another, or you connected with a different I-V Unit that was in the same vicinity (uncommon). • Measuring - Indicates that an I-V measurement is in process. • Paused - Indicates that the I-V Curve Tracer is in the paused state. In this state, PV source connections may be changed without interrupting a measurement. • Disabled - Indicates that I-V measurements are disabled due to a problem. Problems could be related to low battery, over current, over voltage, over temperature, reversed polarity, and so on. No measurements can be taken in this state. Click on the indicator for more information.
5	<p>Measure Now - Click here to make an I-V measurement. This button is disabled when the Status is anything other than Ready.</p>
6	<p>Assign and Save/Reassign - Before the PV model points for a new measurement can be shown on the I-V graph, the measurement must be assigned or saved to a location in the System Tree in the Array Navigator. This allows the model to read information necessary from the tree, such as the number of PV modules in a string, and the wiring characteristics.</p> <p>To save and assign:</p> <ol style="list-style-type: none"> 1. After a fresh measurement, the I-V curve shows, and the System Tree is temporarily shown alongside. 2. Click the location in the System Tree at which the measurement was taken. Then use the Assign and Save button at the bottom of the dialog box to save your data to that location. If you want the model points to appear but do not want to save the trace, click Assign. <p>After a measurement is saved, the Assign and Save button becomes the Reassign button. Click Reassign if you accidentally saved a measurement to the wrong location in the System Tree. When the tree shows, click the correct location and click Assign and Save at the bottom of the dialog box. The location changes and the Measurement ID above the I-V curve shows the new location.</p>

Table 7. Software Main Screen (cont.)

Item	Description
7	<p>Recall... - Recalls measurement data from the System Tree. When the tree appears, click the location in the array tree that contains the desired data. If more than one measurement is stored at that location, select by Date/Time.</p>
8	<p>SolSensor Display Area - If SolSensor is turned on and within wireless range, its real-time sensor values are shown in the lower right of the screen.</p> <p>If the SolSensor is turned off or out of wireless range of the I-V Curve Tracer, Searching for SolSensor appears in this area.</p> <p>If two thermocouples are connected to SolSensor, both temperatures appear. However, it is most common to use only a single thermocouple.</p> <p>If a PV model and a Project have not yet been created, the irradiance value shown is a preliminary value and the value shows in a gray, italic font as discussed in Preliminary vs. Effective Irradiance and shown here:</p> <div style="text-align: center; margin: 10px 0;"> <pre> Irradiance <i>1030 W/m²</i> T backside (1) 55.8 °C (2) 54.1 °C Tilt: 36.4 ° </pre> </div> <p>Once a Project is loaded, irradiance shows in a black, regular font.</p>
9	<p>Voltage (V) - Voltage scale along the horizontal axis of the graph.</p>
10	<p>Measurement Summary Bar - Located below the displayed I-V curve, the Measurement Summary Bar shows the results of the currently displayed measurement.</p> <p>The Performance Factor represents the measured maximum power value as a percentage of the value predicted by the PV model.</p> <p>The Fill Factor (FF) is an indication of the squareness of the I-V curve and is discussed in detail in Interpret Measured I-V Curves.</p> <p>The irradiance, temperature, and tilt measured at the instant that the I-V curve.</p>
(Not Shown)	<p>Power (W) - Displays the power scale along the vertical axis on the right of the graph when the P-V curve is selected in the View menu. The current and power axes auto-scale independently. As a result, the relative heights of the I-V and P-V curves change when auto-scaling occurs.</p>

Menu Bar

File Menu

Click **File** to access the File menu. Use the File menu to create, load, and export Projects.

The File menu has these choices:

- **New Project...**
See [New Project](#).
- **Browse Project...**
Access previously-saved Projects for retrieval.
- **Recent Projects**
Access to recent Projects.
- **Export Trace for Active Measurement...**
Exports the measurement results for the measurement currently shown in the Traces screen, as a csv (comma separated value) file.
- **Export Traces for Entire System...**
Exports the measurement results for the currently loaded Project as a Windows folder tree. The tree is organized in a hierarchy, for example, System\Inverter\Combiner\String IV Data (csv files). Only the last measurement result for each location in the array is exported.
Data in this hierarchical format can be analyzed automatically by the Data Analysis Tool.
- **Export Insulation Resistance Test Data...**
Exports the insulation test data as a csv file for the currently-loaded project. Insulation test data must be collected with a separate insulation resistance meter and entered by the user into the Software.

New Project

To make a new project:

1. Click **File>New Project...** This starts the new Project wizard beginning with the **Site Info** screen.
2. In the Site Info screen, enter the Latitude, Longitude, Array Type, Array Azimuth (True), and the Project time. You can also use the **Lookup City** button to substitute the latitude and longitude of a city near the PV installation.

The Site Info screen has a special feature for horizontal single-axis tracking systems, which allows the I-V curves to be taken as the tracker works. This has the advantage of taking all of the measurements at the greatest possible irradiance level. Enter the morning azimuth of the array (and at solar noon the Software adds 180 degrees for the afternoon azimuth).

Figure 8 shows the array type and azimuth settings for a horizontal single-axis tracker. In this example, the PV modules face east in the morning (before solar noon).

To clarify *azimuth* in a tracker, imagine that the tracker stops at a fixed setting and you want to determine the azimuth at which the modules are oriented. Imagine if a marble is placed on the module glass surface, near the upper frame element, and you release the marble to roll downhill. It rolls down in a straight line, like an arrow, and the projection of that arrow on a horizontal surface (typically the ground, if level) is in the direction of the azimuth of the module.

Figure 8. Most Common Settings for a Horizontal Single-axis Tracking System

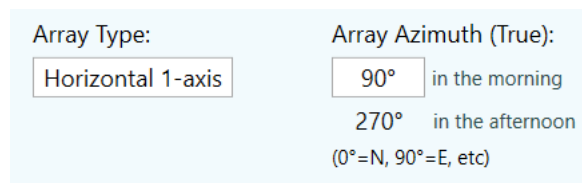

Array Type:	Array Azimuth (True):
Horizontal 1-axis	90° in the morning
	270° in the afternoon
	(0°=N, 90°=E, etc)

3. Make sure that the PC clock is correctly set. These parameters include the time, date, and time zone.

Note

Each measurement made is stamped with the time, date, and time zone as determined from the PC. These values must be correct for the irradiance sensor to correctly interpret the irradiance, and for the Software to correctly calculate the Performance Factor. The time, date, and time zone cannot be corrected after the measurements are taken. It is important to make sure these values are correct before you start to take measurements.

The date/time stamp is determined from the PC that controls the I-V curve measurement process, not the PC on which the PVA project file was originally created (which is sometimes different if, for example, the project file is created in an office on one PC and then the project is sent to a different PC for making measurements).

When the user launches the Software at the PV system site for a day of measurements, check the PC clock first to make sure that the date, time, and time zone are correct.

4. When the Site Info screen is complete, click **Next** to advance to the PV module screen.

Select the PV Module

Select the PV module to make the module performance parameters available to the Project. This allows the Software to calculate the expected I-V curve and the Performance Factor.

To select the PV module:

1. Start to enter the name of the manufacturer, and you are shown a list of similarly-spelled items.
2. Select the name from the generated list.
3. Repeat the process for the model number of the PV module. If the necessary manufacturer or model number is not in the list, click **New Custom...** and enter the manufacturer, model number, and specifications.

Save the data as a custom module. This custom module is stored as part of the Project so that if the project file is shared with another computer, the custom module appears on the second computer.

4. To add that module to the Favorites list, click the star icon. After you have selected the model number, the performance parameters for that module show.
5. Review all parameter values. If edits are needed, use the pencil icon buttons to enter the correct information. If you edit, you can rename that module and save it in the custom equipment folder.

Create the System Tree

When finished with the selection or the edit of the PV module, click **Next** to advance to the Tree Builder screen, see [Figure 9](#).

Figure 9. Array Navigator with Symmetrical Tree Builder

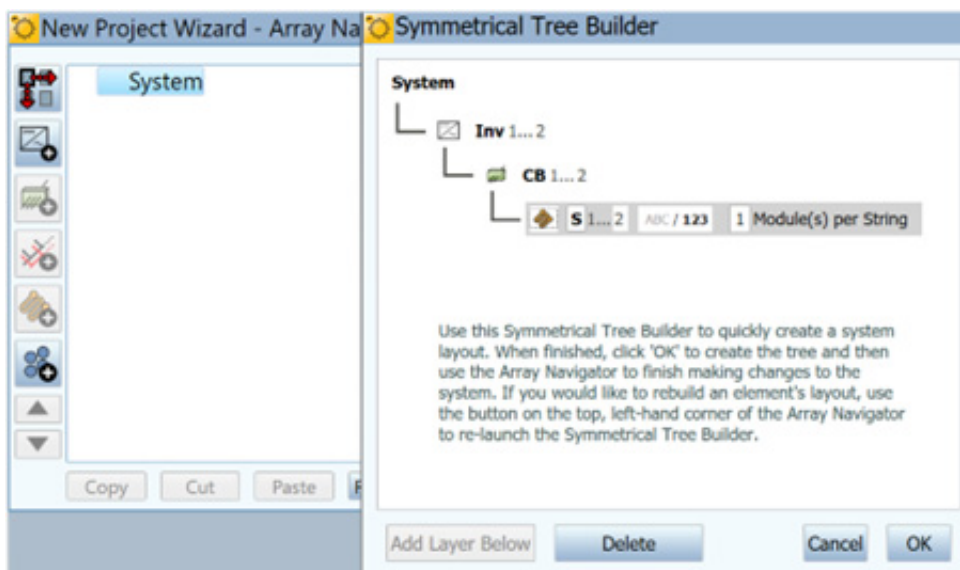

Use this screen to describe the PV system hardware. Use the information entered here to:

- Create a visual *tree* representation of the array that you can *touch* to save and recall the measurement data.
- Specify the # modules per string and wire parameters that the Software model uses to predict expected performance.

An example of a finished array tree is shown in [Figure 10](#). For clarity, the names of the *layers* of the tree have been completely spelled out. In practice, abbreviate the names so that the *path names* for the measurements fit in the Software tree displays and headers and in reasonable-sized spreadsheet cells.

Figure 10. Finished Array Tree

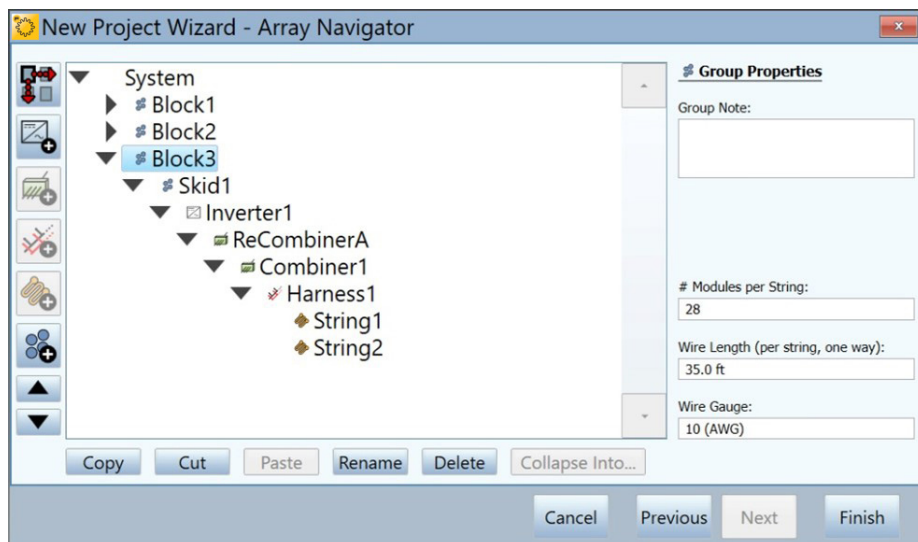

First, use the Symmetrical Tree Builder screen to create the basic structure of the tree. The Symmetrical Tree Builder opens with a default System Tree (with 2 inverters, 2 combiner boxes per inverter, 2 strings per combiner box, and 1 module per string). Edit these defaults to fit the system you will test. If the tree is a large utility-scale project, the design is likely to be modular, and in this first screen you describe that modular, *symmetric* structure that repeats again across the field. Then after running the Symmetrical Tree Builder, you use the Array Navigator screen, to adjust the array tree and account for any non-symmetrical aspects.

Edit the tree so that it matches the design of your PV field. Change any of these parameters:

- Number of layers in the tree.
- Names of the layers
- The quantity in each layer
- Represent items by number or alphabetically
- Number of modules in each string

To add a layer to the tree, highlight the next highest layer and select **Add Layer Below**. To delete a layer, highlight the layer and select **Delete**. A layer can be an inverter, a group, a combiner, or a string. Add a *combiner* layer to represent anything that combines electrical circuits. Add a *harness* when strings are wired in parallel out in the array. Use *group* layers to represent other organizational levels: blocks, parking lots, skids, pads, tracking motor groups, and so on.

There are some limitations on which tree elements can be nested under one another. The rules are based mainly on the requirement that the PV source under test must ultimately nest (directly or indirectly) under an inverter.

Note

For clarity, rename the layers to agree with the naming conventions used in engineering drawings so that there is no confusion about where measurements were made.

Try not to use more non-electrical layers than necessary (block, field, parking lot, and so on) and abbreviate the names of the layers to keep them as short as possible so that the path names for each measurement fit in the display area of the Software, Data Analysis Tool, and final report.

In each layer there are editable fields that show white background when the user highlights a layer. Use these fields to customize the name of the layer, to change the quantity, to use numbers or letters, and in the case of strings, to indicate the number of modules in the string.

When the tree is complete, double-check it against your engineering drawings to be sure it is correct because it is inconvenient to change the structure of this basic tree after you exit the Symmetrical Tree Builder.

After you close the Symmetrical Tree Builder, use the edit features of the Array Navigator to add or delete items, adjust quantities, copy and paste, move up and down, and so on. Often a PV installation includes a smaller PV system to take advantage of remaining space. You can add that system at this time.

When you have finished the edits to the structure of your tree, you can edit the string wiring properties (wire length and wire gauge) of the array. The wiring properties are used by the I-V Curve Tracer model to properly account for those losses. To use the wiring properties controls, first select a level of the tree to which you want the changes to apply. The changes you make are applied to all strings at or below the level of the tree that you edit.

Note

PV systems usually minimize wiring losses, so it is unnecessary to be exact about the wiring characteristics entered. For example, if the strings in a combiner box have one-way wiring lengths that range from 50 ft to 100 ft, you may just want to assign 75 ft to them all. If the entire project has string wiring with that range of length, highlight the top level of the tree (System) to make your edit, and the wiring properties are applied to all strings in the project.

You can also highlight a level of the tree and change the number of modules per string for all strings at that level and below.

When you are finished with the creation of your System Tree, click **Finish** and save your Project.

Copy, Modify, and Reuse a Previous Project

To create a new Project that is similar to one you have created before, copy the earlier Project and adjust it as needed.

To modify a previous project:

1. In Windows File Explorer, navigate to the folder that holds your .pvapx Project file. If you are not sure where to find the Project file, launch the Software, click **File>Browse Project...**, and you will see the path to the last Project you browsed to or click **File>Recent Projects** to see the last few Projects opened in the Software.
2. In Windows File Explorer, highlight the Project file within the Project folder and copy and paste it.
3. Rename the copy with the name of your new project.
4. In the PVA Software, click **File>Browse Project...**, and navigate to the new Project file.
5. Use the screens in the **Properties** menu to edit the Project as needed. Delete all of the data to avoid confusion with any new data. The easiest way to do this is to delete the inverters and build a new tree.

Properties Menu

Use the **Properties** menu to set, view, and edit settings of the currently-loaded Project. These menu items access the same screens that appeared in the New Project Wizard. See [New Project](#).

View Menu

Trace view options...

The choices in [Figure 11](#) select which features show in the Traces screen. To show this legend at the bottom of the Traces screen, check **Show legend under chart**.

Figure 11. View Menu

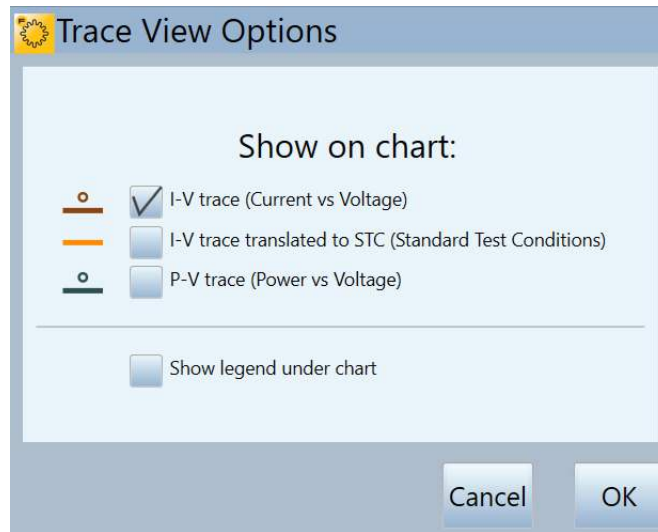

Show Insulation Test Tab

Click the check box to show the **Insulation Test** tab at the left of the measurement screen.

Utility Menu

The **Utility** menu provides access to housekeeping functions and miscellaneous tools. The Utility menu is described in [Table 8](#).

Table 8. Utility Menu

Menu Item	Description
Calibration Verification...	See Calibration Verification for a description of this dialog.
Enable Manual Sensor Configuration	Check this menu item to allow changes to the irradiance, temperature, and tilt readings. See Measure Irradiance, Temperature, and Tilt for guidance on sensor choices.

Table 8. Utility Menu (cont.)

Menu Item	Description
Global Sensor Configuration...	<p>Use these controls to change the sources of the irradiance, temperature, or tilt readings for all measurements currently saved in the project. Select the necessary sensors from the drop-down lists. Create a backup file before taking this action. This action cannot be undone.</p> <p>See Measure Irradiance, Temperature, and Tilt for guidance on sensor choices.</p>
Set I-V Curve Resolution...	<p>Use to select the number of points in your I-V curve measurements.</p> <ul style="list-style-type: none"> • Select 100 points for commissioning and most troubleshooting (smaller data files and faster data transfers). • Select 500 points for research or more detailed troubleshooting applications (larger file sizes and slower data transfer).
Configure Measurement Alert Thresholds...	<p>Set thresholds that the Software automatically checks after each measurement is <i>Assigned and Saved</i> (but not if the measurement is only <i>Assigned</i>). Use these alerts to catch problems before you move to other circuits or leave the site.</p>
Battery Level...	<p>Use this option to see the battery voltage levels or click on the Status indicator. For accurate battery readings, wait 30 seconds to check the battery voltage if you just removed the I-V Curve Tracer from the charger or just turned on the I-V Curve Tracer.</p> <p>The Software reports the battery levels of both the I-V Curve Tracer and SolSensor.</p> <p>The I-V Curve Tracer and SolSensor both shut down when the battery voltage drops below 3.05 V. A warning shows in the Software before the shutdown.</p> <p>The type of Lithium ion battery used in these instruments has a square discharge curve, so there is relatively slight variation in battery voltage from the fully-charged state to the shutdown level.</p>
Capture Application Screen...	<p>Captures and saves the current screen to an image file.</p>

Help Menu

See [Table 9](#) for a description of the Help menu.

Table 9. Help Menu

Menu Item	Description
Connected Measurement Devices...	When selected, a figure shows the network diagram, which represents your PC, I-V Curve Tracer, SolSensor, and the wireless signal levels between them. When you use the I-V Curve Tracer and SolSensor, the I-V Curve Tracer relays all communications between the PC and SolSensor. Also refer to this screen to find out what firmware version is in the I-V Curve Tracer and SolSensor and to check for available firmware updates. Have this information ready when you call Fluke for product support.
User's Guide...	Accesses the I-V Curve Tracer Users Manual. Download and print if necessary. The manual is also available from the Fluke website.
About...	Shows the Software version number and software build date. Have this information ready if you call Fluke for product support.

Tab Screens

The tabs along the left edge show measurement data in various ways. Certain elements are common to more than one tab. These include the **Status** indicator, **Measure Now**, **Assign and Save...**, **Reassign...**, the wireless sensor displays, and the **Environmental Inputs** slide-up panel.

Traces Tab

The **Traces** tab shows the most recent measurement results and the predicted shape of the I-V curve (if a PV model is defined). See [Table 7](#) and [Table 20](#).

Select **View**, then **View Options** to choose the necessary view:

- **I-V curve** - The solid red curve shows the measured I-V points transmitted from the I-V Curve Tracer.
- **I-V curve prediction markers** - The three red dots are the predicted I-V points for the short circuit current I_{sc} the maximum power point (I_{mp} , V_{mp}), and the open circuit voltage V_{oc} .

- **P-V curve** - The solid blue curve shows the power versus voltage curve (P-V) available from the PV circuit under test (module or string), and is calculated from the I-V curve by multiplying $I \times V$ for each I-V point. The blue point marks the maximum value on the P-V curve (P_{max}). This value is calculated by fitting a mathematical curve to the top of the P-V curve and then calculating the maximum value of the fitted curve. This reduces the impact of electrical noise on measurement accuracy. The location of the blue marker is derived from the measured P-V curve and not from the PV model.
- **I-V curve translated to STC.**

Table Tab

The **Table** tab presents summaries of the predicted and measured I-V data and a translation of the measurement results to Standard Test Conditions. [Table 10](#) explains the Table screen. See [Traces Tab](#) for explanations of other controls shown on this screen.

Table 10. Table Tab Description

		Measured	Predicted	Meas translated to STC
15	Performance (%)	96.8	---	---
14	Fill Factor	0.77	0.76	0.74
13	Pmax (W)	21980	22700	27930
12	Irr (W/m ²)	895.5 (SolSensor)	---	1000
11	Isc (A)	24.1	25.0	26.3
10	Cell Temp (°C)	50.9 (SmartTemp)	---	25
9	Voc (V)	1184	1184	1429
8	Imp (A)	22.4	22.6	25.0
7	Vmp (V)	983.3	1006	1119
6	Tilt	17.4 (SolSensor)	---	---
5	Current Ratio	0.92	0.90	0.95
4	Voltage Ratio	0.83	0.85	0.78

Item	Description
1	Measured Column - Shows most recent measured values.
2	Predicted Column - Shows the predicted values from the performance model.
3	Meas Translated to STC Column - Shows the measured parameters translated to Standard Test Conditions, 1000W/m ² irradiance and 25 °C cell temperature.
4	Voltage Ratio - The voltage ratio is a relative indication of the slope of the vertical leg of the I-V curve. Voltage ratio is defined as V_{mp}/V_{oc} . See Interpret Measured I-V Curves .

Table 10. Table Tab Description (cont.)

Item	Description
5	Current Ratio - The current ratio is a relative indication of the slope of the horizontal leg of the I-V curve. Current ratio is defined as I_{mp}/I_{sc} . See Interpret Measured I-V Curves .
6	Tilt - Tilt of array.
7	V_{mp} (V) - Voltage at the maximum power point.
8	I_{mp} (A) - Current at the maximum power point.
9	V_{oc} (V) - Open circuit voltage. V _{oc} is measured immediately before the actual I-V sweep. This V _{oc} value is accurate even if the measured I-V curve does not extend completely down to the horizontal axis.
10	Cell Temp (°C) - Cell Temperature. This differs from the backside thermocouple measurement. A model predicts the temperature drop from the cell to the backside to get the cell temperature.
11	I_{sc} (A) - Short circuit current. The first point of the I-V sweep is slightly to the right of the vertical axis of the I-V curve graph. The PVA software draws a horizontal line from this point back to the vertical axis.
12	I_{rr} (W/m²) - Irradiance. The modeled effective irradiance.
13	P_{max} (W) - Measured maximum power.
14	Fill Factor - The Fill Factor (FF) is an indication of the squareness of the I-V curve. See Interpret Measured I-V Curves .
15	Performance (%) - The Performance Factor is the ratio of the measured max power to the predicted max power. See Interpret Measured I-V Curves .

History Tab

The **History** tab automatically accumulates the tabular results of your most recent measurements. New results are in the left column. Previous results are shifted to the right. The table holds a maximum of 32 results. Once that limit is reached, the oldest measurement result drops from the table each time a new measurement is taken. The parameters shown in the History tab are identical to the results shown in the Table tab. Additional parameters appear when the **Show Advanced Parameters** box is checked, these are shown in [Table 11](#).

Table 11. History Tab (Advanced Parameters) Description

	11/30/2021 11:55:06 AM	11/30/2021 11:54:18 AM	11/30/2021 11:53:52 AM	11/30/2021 11:53:35 AM	11/30/2021 11:53:14
Traces					
Array Location					
Performance (%)					
Table					
Fill Factor	0.77	0.78	0.78	0.78	0.77
Pmax (W)	7941	7427	5993	6067	7459
Irr (W/m ²)					
Prelim Irr (W/m ²)	769.5	719.1	518.7	583.4	718.3
History					
Irr Sensor					
Isc (A)	7.78	7.28	5.88	5.99	7.33
Cell Temp (°C)					
TC1 (°C)	39.1	38.3	39.7	39.7	39.1
TC2 (°C)					
Temp Sensor					

Item	Description
1	Prelim I_{rr} (W/m²) - Preliminary Irradiance. This is the raw irradiance measured from the SolSensor. The measurement includes calibration and temperature corrections, but does not include the model correction for effective irradiance. Compare Preliminary Irradiance to the Modeled Effective Irradiance when there appears to be a problem with the Irradiance indication. See Preliminary vs. Effective Irradiance .
2	I_{rr} Sensor - Irradiance Sensor input configuration. For example, this could be SolSensor, From I-V, or Manual. Enable Manual Sensor Configuration in the Utility Menu. See Utility Menu .
3	TC1 (°C) - Thermocouple 1 temperature reading. Look at this to understand the SmartTemp value.
4	TC2 (°C) - Thermocouple 2 temperature reading. Look at this to understand the SmartTemp value.
5	Temp Sensor - Temperature Sensor input configuration. For example, this could be SolSensor, TC1, TC1, Avg(TC1, TC2), From I-V, or Manual. Enable Manual Sensor Configuration in the Utility Menu. See Utility Menu . Note that this appears only when Show advanced parameters is checked.

The History tab is especially useful to inspect the agreement between measurements taken at a combiner box during commissioning tests, and also to see sequential steps in a troubleshooting sequence. For example, when you use the Selective Shading Method to find the failing module in a string of N (quantity) modules, you can use the History Tab to show and compare the N measurement results. The column with the values that stand out compared to the other columns corresponds with the shaded the bad module.

The current contents of the History table are saved in your Project file, so the most recent contents will still be there when you close and re-open the Project. However, the contents are not saved to the System Tree like your I-V curves, and when you recall an I-V curve from the System Tree, the History table is not updated to match that recalled measurement. Also, the History table contents are not exported when you export your I-V curve data.

Insulation Test Tab

Use the Insulation Test tab to record insulation resistance measurement results obtained from a separate instrument such as the Fluke 1587FC Insulation Resistance Tester. The Insulation Test Tab is hidden by default. To show this tab, use the control in the View menu. See [Table 12](#).

Table 12. Insulation Test Tab Description

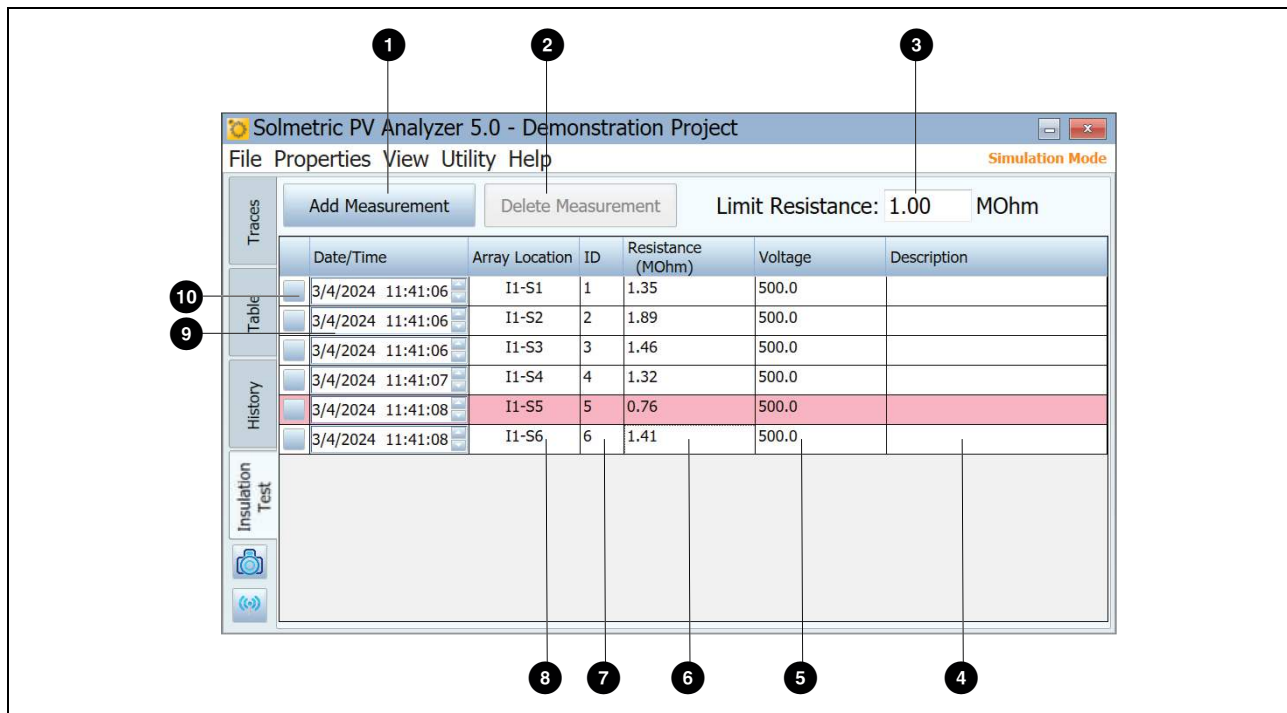

Item	Description
1	Add Measurement - Adds a new line to the table, lists the current date and time, and the line is assigned an ID number. Enter the insulation resistance value.
2	Delete Measurement - Deletes the currently-selected measurement from the list.

Table 12. Insulation Test Tab Description (cont.)

Item	Description
3	Limit Resistance - Enter the minimum acceptable value of insulation resistance. Any measured values that are below this limit are highlighted in red in the table.
4	Description - Optional description of the measurement or circuit.
5	Voltage - The voltage at which the insulation resistance was measured. Click this field to enter the value.
6	Resistance - The measured value of insulation resistance in megohms. Click this field to enter the value.
7	ID - Automatically assigned identification number. The ID number increments by one count each time a measurement is added.
8	Array Location - Accesses the System Tree to select the location at which the measurement was made.
9	Date/Time - Shows the date and time each measurement was added to the table.
10	Selection box - Selects the measurement to delete. Click Delete Measurement to delete selected measurement.

The Exported I-V Data File

This section describes the organization of the csv file created when you export measurements from the Software.

I-V Curve Tracer users typically analyze their measurement results with the Data Analysis Tool (DAT) Excel macro which automates the analysis and reporting process. Download a free copy of the DAT by visiting www.fluke.com. To use the DAT, first export your Project data from the I-V Curve Tracer by selecting **File>Export Traces for Entire System...** See [File Menu](#) and then import that data into the DAT (see the instructions in the DAT software for how to import).

When you export Project data, the Software creates a folder tree on your hard drive that has the same hierarchy as your Array Navigator system tree. The I-V trace data exports to this folder structure in csv files. If you measured strings of PV modules but did not save measurements of the individual modules in the strings, the lower-level directories in your folder structure contain the string I-V trace csv files.

When you use the Data Analysis Tool, import some or all of this data into the DAT for automated analysis and reporting. Browse to the necessary level of the folder hierarchy.

To view the individual I-V trace data files, use a program that can read csv files, such as Microsoft Excel™. This section describes the organization and contents of the csv file.

Table 13 shows the header information section of the csv file.

Table 13. CSV Header Information

SOLMETRIC PVA IV DATA		2
Report Date	9/18/2013	
Report Time	11:46:31 AM	
Software Build	1.1.6798	
Project File	County Fairgrounds building A	
Array Location	Inverter1-Combiner2-String5	
PVA Measurement Unit MAC Address	00158D0000227CE7	
SolSensor Unit MAC Address	00158D00001C6707	
Menu Item	Description	
Report Date and Time	When your measurement was made, as recorded from the clock on the PC.	
Software Build	The version of I-V Curve Tracer software that took this measurement.	
Project File	The name of your Project File at the time this measurement was taken.	
Array Location	The location in the System Tree at which the measurement was saved. Normally, this maps directly into the hierarchy of the actual array.	
PVA Measurement Unit MAC Address	The unique network address of the I-V Curve Tracer.	
SolSensor MAC Address	The unique network address of SolSensor.	

Figure 12 shows the values of some of the measured and predicted points on the I-V curve. The abbreviations represent maximum power (P_{max}), maximum power voltage (V_{mpp} or V_{mp}) and maximum power current (I_{mpp} or I_{mp}), open circuit voltage (V_{oc}), and short circuit current (I_{sc}).

In the Software, the value of P_{max} is obtained by fitting a third-order polynomial curve to the P-V (Power vs. Voltage) curve, and then calculating V_{mp} (max power voltage) from the peak of the fitted curve. This value of V_{mp} is then used to interpolate I_{mp} (max power current) from the I-V curve. This method reduces the amount of uncertainty contributed by electrical noise in the current and voltage measurements. The Data Analysis Tool (DAT) re-calculates P_{max} for the charts and reports data. It optionally fits a fourth-order polynomial, which can result in a slight difference in V_{mp} , I_{mp} , and P_{max} between the Software and the DAT and is generally a better fit.

Figure 12. Measurement vs. Model Selection of Exported CSV File

	MEASUREMENTS	MODEL PREDICTIONS
Pmax	1639.091342	1303.786362
Vmpp	407.1462651	391.6482064
Impp	4.025804685	3.328973146
Voc	514.4149505	517.2308276
Isc	4.695322551	3.879695677

Table 14 shows the SolSensor Measurements section of the exported csv file, and the table describes the contents. All of the values were recorded at the time the I-V measurement was made.

Table 14. SolSensor Measurements Section of Exported CSV File

SolSensor Measurements	
Irradiance (W/m ²)	607.3874995
Temperature Thermocouple 1 (Deg C)	50.24752808
Temperature Thermocouple 2 (Deg C)	#N/A
Pitch (Deg)	15.03951045
Roll (Deg)	-0.124151007
Tilt (from pitch and roll above) (Deg C)	15.04001105

Menu Item	Description
Irradiance	Value of irradiance measured by SolSensor integrated Silicon photodiode sensor. This is the Preliminary Irradiance and is calibrated and temperature corrected, but is different from the Effective Irradiance. Effective Irradiance is used in the PV model and is generally a better irradiance match for the modules selected than the preliminary irradiance.
Temperature Thermocouple 1	The temperature indication from the thermocouple plugged into SolSensor TC1 socket.
Temperature Thermocouple 2	The temperature indication from the thermocouple plugged into SolSensor TC2 socket.
Pitch	The angle of SolSensor about its short axis..
Roll	The angle of rotation of SolSensor about its long axis.
Tilt	SolSensor tilt, calculated from the pitch and roll.

Table 15 shows the Model Details section of the exported csv file.

Table 15. Model Details Section of CSV File

MODEL DETAILS		
Irradiance used in model (W/m ²)	607.3874995	Method: Measured
Cell Temperature used in model (Deg C)	56.04130905	Method: SmartTemp
Tilt use in model (Deg)	15.04001105	Method: Measured
Array Azimuth (Deg)	232	
User Series R (Ohms)	0.059934	
Performance Factor (%)	125.7	
Latitude	39	
Longitude	-122.92	
Time Zone	-8	
Module Mfr	Schott Solar	
Module Model	ASE-300-DGF/42-240	
# of Modules in String	11	
# of Strings in Parallel	1	
Inverter Mfr	Undefined Inverter	
Inverter Model	#N/A	
Wire AWG	10	
Wire Length (ft; one way)	30	

Item	Description
Irradiance used in model	The value of effective irradiance used in the predictive model.
Cell temperature used in model	The value of PV cell temperature used in the predictive model.
Tilt used in model	The value of array tilt used in the predictive model.
Array azimuth	The compass direction the array faces. 0=N, 90=E, 180=S, 270=W.
User Series R	The resistance of the conductors between the point of measurement and the PV source (typically, the home run conductors), calculated from the wiring details entered by the user when the Project was created.
Performance Factor	The ratio of measured to predicted maximum power, expressed in %.
Latitude and Longitude	The location on Earth where the measurement was made.

Table 15. Model Details Section of CSV File (cont.)

Item	Description
Time zone	The time zone in which the measurement was made.
Model Mfr	Manufacturer of the PV module.
Module Model	Model number of the PV module.
# of Modules in String	Number of modules connected in series in the measured string.
# of Strings in Parallel	Number of strings measured in parallel.
Wire AWG	Wire gauge of the conductors between the point of measurement and the PV source.
Wire Length	Length (one-way, in ft) of the conductors between the point of measurement and the PV source.

Figure 13 shows the voltage, current, and power data saved from the measurement. The number of entries depends on the I-V curve resolution selected by the user for this particular measurement (default 100 points, user settable to 500 points).

The saved data array in Figure 13 does not include the final values of I_{sc} or V_{oc} (final values are as shown in Figure 10). The PV model projects the first current point onto the vertical (current) axis of the I-V graph to calculate I_{sc} . The uncertainty introduced by this step is minimal. The final value of V_{oc} is measured an instant before the start of the I-V curve sweep with a separate, internal high-impedance voltmeter. This assures that the PV source circuit is truly unloaded when you measure V_{oc} .

Figure 13. Voltage, Current, and Power Data from I-V Measurements

IV Measurements:		
VOLTS	AMPS	WATTS
19.39205301	4.695322551	91.05194381
37.82583013	4.65872928	176.2203024
56.13733349	4.636366726	260.2732651
74.14267981	4.618070091	342.3960921
92.20926973	4.599773455	424.1417512
110.1228116	4.585542739	504.9728592
127.8525617	4.567246104	583.9341142
145.5516595	4.546916509	661.8112433

Basis of PV Performance Predictions

The Software predicts the electrical output of the PV source under test (module or string) based on the module parameters, the irradiance and temperature, the sun's angle of incidence on the array, and other factors. The subsequent discussion outlines the process by which SolSensor is calibrated and measures irradiance, and the process by which the Software predicts the three expected points on the I-V curves.

SolSensor Irradiance Calibration

The SolSensor factory calibration process involves this sequence of steps:

1. Calibration of the electronic tilt sensor.
2. Calibration of the angular response of the irradiance sensor.
3. Calibration of irradiance measurement at air mass 1.5 and normal incidence, relative to a solar simulator.
4. The unique calibration coefficients are stored in SolSensor and are transmitted to the Software on demand.

Irradiance Measurement

SolSensor measurement of irradiance involves these steps:

1. Clamp SolSensor to the module frame to orient it in the plane of the array.
2. The position of the sun relative to the orientation of the irradiance sensor is calculated based on the array azimuth and tilt, the time and date, and the site latitude and longitude.
3. The irradiance value is temperature corrected based on the indication of a temperature sensor attached to the irradiance sensor and based on the angle of incidence of the irradiance.
4. One of four spectral corrections is applied, according to the PV module technology (poly-Si, c-Si, HIT-Si, or CdTe) of the array. The corrections are derived from module/sensor spectral overlap calculated by SMARTS atmosphere model as a function of air mass and elevation.

This process yields the effective irradiance incident on the cells in the PV module. Effective irradiance is the portion of the total irradiance that the module can convert into electricity.

Prediction of PV Performance

The Software compares the measured I-V curve to the predictions of the built-in PV performance model. The Performance Factor is calculated from this comparison.

The prediction process involves these steps:

1. Create a Project and input all required parameters that include selection of the PV module from the built-in equipment database.
2. The model predicts I_{sc} , I_{mp} , V_{mp} , and V_{oc} for the current values of irradiance and temperature.
3. Under low-light conditions, the prediction is adjusted based on 200W/m² performance data in the database.
4. The Performance Factor - the ratio of measured Pmax to predicted Pmax - is calculated and expressed in percent. The Performance Factor is the most important metric of the performance of the PV module or string.

Translation of Measured Values to STC

Measured values of I_{sc} , I_{mp} , V_{mp} , and V_{oc} are translated to STC with the irradiance and temperature dependence factors stored in the model database, and the translation equations from, [Translation of I-V Data to Standard Test Conditions](#).

Measurement of I_{sc}

The I-V Curve Tracer uses a pre-charge capacitor to start the I-V sweep at a slightly negative voltage, to overcome small voltage drops and transients inherent in the measurement loop and ensure that the true I_{sc} value is measured. Under certain circumstances of PV source under test, this pre-charge may not be sufficient to start the I-V trace at or below 0 V. In such cases, a small gap occurs between 0 V and the first measured I-V pair, and the Software constructs a horizontal line from the first measured I-V point to the vertical axis to estimate I_{sc} . The intersection of the horizontal line with the vertical axis is reported as I_{sc} . In most cases, this is an extremely close approximation.

The high-efficiency modules store a large amount of electrical charge. At the start of the sweep, this reservoir of charge quickly flows into the pre-charge capacitor and steps its voltage such that the first I-V point is in positive voltage territory. In some instances, especially with 500 points, the first few I-V points may be slightly elevated due to the residual discharge of the PV module capacitance. In such cases, you may see a slight, flat plateau in the I-V curve just above 0 V. This deviation from actual I_{sc} is typically extremely small. This typically does not occur with the PVA-1500HE2 because it handles strings of high efficiency modules and their large in-rush current.

Calibration Verification

The I-V Curve Tracer includes a dialog called **Calibration Verification**. This is typically used by laboratories equipped to verify calibrations. To access, click **Utility>Calibration Verification**. This dialog shows continuous measurements of voltage, irradiance, thermocouple 1, thermocouple 2, and tilt. This dialog can be used to verify the calibration and accuracy of the PVA sensors. The irradiance reading is the Preliminary Irradiance that includes calibration factors and temperature correction but does not include further modeling (for example, for effective Irradiance). This reading is suitable to compare the SolSensor reading to a reference cell outdoors under stable irradiance conditions or with a solar simulator. Verify current calibration and accuracy with the setup described in the app note *PV Analyzer Calibration Application Note* (see link in the dialog) and push the **Measure I-V Unit Current** button. Adjustment to the calibrations must be done by Fluke.

Software Updates

The Fluke website posts software and manual updates. Periodically check the website at www.fluke.com to download the latest of both. Compare the Software and manual version numbers with the versions that you have. To update the software or manuals, download the latest versions and run the free Software installer. See [Help Menu](#) to locate your current Software version.

I-V Curve Tracer and SolSensor Firmware Updates

The firmware of the I-V Curve Tracer and SolSensor can be updated in the field.

When the PC is connected to the Internet and you launch the Software, the Software downloads the most current firmware versions for the I-V Curve Tracer and SolSensor. Then the next time your PC is Wi-Fi connected to the two instruments, the PC software reads their current firmware versions and recommends that you run the update if necessary. Once downloaded, the updates take approximately 2 minutes per instrument and do not require an Internet connection. If your SolSensor is not with you, or is not turned on, or is not within Wi-Fi range when you run the update process, only the I-V Curve Tracer firmware is updated, and you can update SolSensor firmware the next time it is wirelessly connected to the I-V Curve Tracer.

To manually check the I-V Curve Tracer and SolSensor firmware versions:

1. Launch the Software.
2. Wirelessly connect to the instruments.
3. Select **Help**.
4. Select **Connected Measurement Devices**.

The current versions of firmware are shown. Periodically launch your Software while connected to the Internet to see notices of any Software updates. From there, download recent firmware updates and have them ready to update your instruments in the field.

Make Measurements

This section describes the steps to take measurements in the field. See the printed Safety Information that ships with the I-V Curve Tracer.

Before You Take Field Measurements

Charge the Equipment

Before you bring your instruments to the field, charge both the I-V Curve Tracer and SolSensor overnight.

- If the Software is running and the I-V Curve Tracer and SolSensor are connected, a lightning bolt charge icon appear in the upper right over **I-V** or **SS** as they charge.
- If the internal temperature of the I-V Curve Tracer is too hot (for example, due to many high voltage I-V sweeps and/or hot environmental conditions), the battery does not charge and the I-V charging icon has a red **X** over it. SolSensor may also be in an over-temperature state, although it is less common than for the I-V Curve Tracer.

The equipment typically runs for 7 hours to 8 hours on a charge. Turn the equipment off when not in use.

Make Sure to Run the Latest Software

Double click the PVA icon on your PC to run the Software. See [Software Updates](#).

Create a Project in the Software

Create a Project ideally where you have an Internet connection and engineering drawings of the PV installation. For large plants this is often done at the office before entry into the field. Make sure that the created Array Tree accurately represents the architecture of the PV system. See [New Project](#).

Assure Adequate Irradiance for Your Measurements

Performance measurements are best performed in the range of 700 watts to 1000 watts per square meter. If possible, choose a day when the skies are clear. If there are clouds, try to trigger measurements at the moments when there are no clouds near the sun. Also try to take measurements in a 6-hour window centered on solar noon.

If you measure a horizontal single-axis tracker, you can set up the Project to allow the tracker to run as you take measurements. This provides a more consistently-high irradiance in the day.

Measurements in the Field

Measure the Open Circuit Voltage (V_{oc})

If the open circuit voltage (V_{oc}) of the PV source circuit exceeds the maximum dc input voltage specification of the I-V Curve Tracer, your Product may be damaged. Before you start measurements at a new PV field, measure a string with a properly-rated digital multimeter (DMM) to make sure V_{oc} is within the dc voltage range of the I-V Curve Tracer. This step prevents damage to the Product and saves time.

Connect the I-V Curve Tracer Test Leads

Slide open the banana jack dust cover on the I-V Curve Tracer and connect the banana jacks to the I-V Curve Tracer (red to red, black to black). There are two types of test leads, banana to alligator clip and banana to MC-4.

Connect the alligator clips to the ends of the test leads. Make sure to use only the 1500 V rated test leads and alligator (dolphin) clips supplied by Fluke with the I-V Curve Tracer.

Launch the Software

Double click the desktop PVA icon to start the Software.

Load Your Project

Select your Project from the **File** menu in the Software. The Project must be created specifically for the PV installation you are about to measure.

Measure Individual Strings versus Parallel Strings

Typically, you should measure each string individually to get the best insight and resolution in the performance. If you measure multiple strings in parallel, make sure that the maximum PV current you plan to measure is less than the specified maximum current of the I-V Curve Tracer. To estimate the maximum current the paralleled strings will produce, measure a single string in full sun, and multiply the measured short circuit current (I_{sc}) by the number of strings you plan to measure in parallel. Be aware that the maximum total current increases when the sun is more directly in front of the array, and that in the span of a few seconds, cloud edge effects can increase total current more than 25 % above normal clear-sky conditions.

Measure High-efficiency Modules

High-efficiency modules have high capacitance that cause a large in-rush current when I-V curves are measured. The PVA-1500HE2 handles this in-rush current for strings of high efficiency modules up to 30 A.

The PVA-1500T2 handles this in-rush current from PV circuits up to 30 A short circuit current when the module efficiency is <19% or up to 10 A short-circuit current when the module efficiency is $\geq 19\%$. The in-rush current is increased by higher efficiency, higher current strings, higher voltage strings, higher bifaciality, and higher irradiance. For example, a 1350 V string of bifacial 21% efficiency modules with I_{sc} of 18 A at irradiance around 1000W/m² will likely cause the over-current warning in a PVA-1500T2. Lower string voltages can allow currents higher than 10 A, even with high efficiency modules, so breaking-up strings to reduce voltage and adjusting tracker orientation for lower irradiance can be an I-V measurement solution in some cases. For more information on high efficiency modules, see the Solmetric app note I-V Curve Tracing of High Efficiency PV modules.

Connect the Test Leads to the PV Equipment

Observe the correct polarities (red test lead to dc positive, black test lead to dc negative).

If you measure circuits at a combiner box, after you open the dc disconnect switch to disconnect from the inverter and lift all the fuses (if the combiner has one fuse per string) or lift all of the positive-side fuses (if the combiner has two fuses per string), connect the PV test lead alligator clips to the positive and negative buss bars. This allows you to insert one string fuse at a time to select the PV circuit to test.

Select the First PV Circuit to be Measured

If you use the string fuses to select PV circuits, insert the first fuse.

Make the First Measurement

Push **Measure Now**. The measured trace typically appear in 1 second to 11 seconds. See [Figure 14](#).

Figure 14. Results of an I-V Curve Measurement

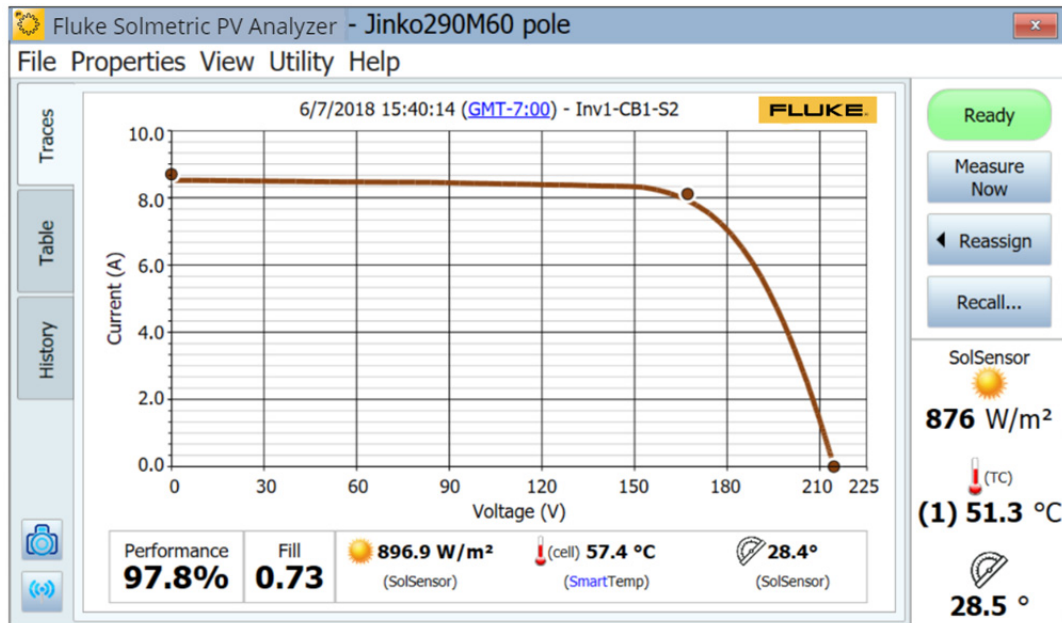

After the measured I-V curve trace appears, the I-V graph slides to the left and the PV system Array Tree appears at its right.

Navigate to the location in the tree that matches where you took your measurement. Highlight that branch of the tree and click **Assign and Save**. If you do not want to save the trace but only want the software to compare the measured trace with the predictions of the PV model, instead push **Assign Only**.

When you Assign and Save, the software performs checks (Alerts) to automatically detect problems. For more information, see [Alerts](#).

The Array Tree closes and the I-V curve expands to its full width.

Inspect the curve for abnormal shapes and notice the values of the Fill Factor and the Performance Factor below the I-V curve graph. Fill Factor gets smaller if the I-V curve is poorly shaped. Expect Performance Factors to be mostly in the 90 % to 100 % range for a new, clean array. If the values are much higher or lower than that, check that the irradiance sensor is mounted in the plane of the array, that the PC date, time, and time zone are correct, that the PV module parameters are correct, and that the array azimuth and array type are correctly set.

Inspect the sensor values that were saved with the measurement. They are directly below the I-V curve graph.

Select the Next PV Circuit and Make Another Measurement

If working within a combiner box, lift the previous fuse and insert the next one. Repeat the above steps to make and save your measurement.

Be aware that when your measurements are finished and the data is exported from the Software, the Software exports only the last measurement saved to each branch of the Array Tree. If you take extra measurements while troubleshooting a string that under performs, be sure to take one final measurement of the repaired string, for export.

View Consistency of Data

Before you move to the next combiner box or inverter, click the **History** tab and scroll left-to-right to see the numerical results of the measurements at this combiner box. The most recent measurement appears in the left column. Check for any outliers.

For example, the V_{oc} values should be closely grouped to indicate that the strings all have the right number of modules.

The I_{sc} values should also be closely grouped if it is a clear day and the irradiance is nearly constant.

A low Fill Factor means that the shape of the I-V curve is degraded. This can be caused by shading, soiling, or debris or equipment on the modules under test. See [Interpret Measured I-V Curves](#).

It helps to clear the History table before you move to the next combiner box.

Alerts

After you make a measurement and select **Assign and Save**, the Software does automatic checks to detect potential problems with the measurement setup or with the circuit under test. These are called Alerts. [Table 16](#) lists the Alert types. Some Alerts can be disabled from appearing again within the session. Disabled alerts become re-enabled when the software is re-started. Alerts only appear when a project with a model is loaded.

Table 16. Alert Messages

Alert	Description
Large deviation in Effective vs. Preliminary Irradiance	If the modeled effective irradiance deviates from the preliminary irradiance by more than 25 %, the Software shows an Alert that indicates the irradiance is deviating. This happens if the longitude, latitude, time/ date, or azimuth is incorrect in the Site Info or if SolSensor is not mounted in the plane-of-array.
Smart Temp Detected Problem	If the SmartTemp algorithm detects a deviation of >8 °C between the blended temperature calculation vs. the thermocouples, the Software shows an Alert to indicate the deviation.
Large Deviation between Thermocouples	If the deviation between thermocouple indication is >5 °C, the Software shows an Alert to indicate the deviation.
No SolSensor Readings	If SolSensor does not receive data or is not connected to the Software, the Software shows an Alert to indicate the condition. Determine whether to accept the trace without SolSensor data or discard the trace.
User-Set Threshold Exceeded	If one of the user-defined alert thresholds is exceeded, the Software shows an Alert to indicate the deviation (for example I_{sc} alert). Select Configure Measurement Alert Thresholds in the Utility menu to configure the user-defined Alerts.

Data Backup

The Software has an automatic backup feature. By default, the Software backs up the Project every 20 times that you save an IV trace. To enable or disable this functionality, change how often it backs up, or change the backup folder location, select **File>Project Backup Settings...** To manually create a backup, click **Create Backup Now**.

Measure Irradiance, Temperature, and Tilt

Thorough evaluation of array performance by any measurement method involves comparing measured data to a reference. That reference may come, for example, from a simple STC maximum power value or from a detailed PV performance model. In any case, you must know the irradiance in the plane of the array and the array temperature to properly evaluate array performance against your reference.

You must consider a number of factors to assure good measurement results. This section provides the background necessary to make informed choices for your specific application.

Measuring irradiance presents a number of requirements and challenges:

- Irradiance must be measured in the plane of the array (POA)
- Irradiance may not be uniform across the surface of the array due to shading and albedo effects, as well as local cloud effects
- Irradiance can vary rapidly
- Irradiance sensors may have different spectral responses than the PV modules themselves
- The solar spectrum shifts significantly early and late in the day
- The shape of the PV module I-V curve changes at low irradiance levels

The temperature parameter of interest to the PV model is the average temperature of the PV cells in the string or module under test. To determine the average cell temperature poses a number of challenges:

- The PV cell is embedded in other materials, so you cannot measure the cell temperature by direct contact.
- The materials in which the PV cell is embedded have poor thermal conductivity, so there can be substantial temperature drop between the cells and the module front side or back side.
- Temperature offset between the PV cell and module backsheet depends on racking configuration and ventilation as well as current irradiance.
- Temperature is not uniform across a PV module or array due to variations in racking configuration and ventilation.
- Temperature at a given location can vary with time, even at constant irradiance, due to convection currents and wind.
- An air gap between a backside temperature sensor and the actual backside surface results in significant temperature error.
- Massive temperature sensors, particularly bulky RTD devices, do not track rapid changes in module temperature.
- Surface and material issues limit the accuracy of infrared temperature measurements.

The Software provides multiple methods to measure irradiance, temperature, and tilt, as shown in [Table 17](#).

Table 17. Sensor Choices

Irradiance	Temperature	Tilt
SolSensor	SmartTemp	SolSensor
From I-V curve	From I-V curve	Manual entry
Manual entry	Thermocouple 1	-
-	Thermocouple 2	-
-	Average of TC1 and TC2	-
-	Manual entry	-
Use any combination of methods depending on the requirements of your application.		

Measure Irradiance with SolSensor

SolSensor Irradiance Sensor

Fluke recommends, in most cases, to use the SolSensor as the source of the irradiance measurement. The SolSensor irradiance sensing element is a silicon photodiode with temperature correction. Its spectral response is corrected to match silicon solar cells and its angular response is corrected to provide enhanced accuracy over a broader part of the day.

Preliminary vs. Effective Irradiance

SolSensor produces a preliminary irradiance that is calibrated and temperature corrected (for the temperature of the photodiode). The preliminary irradiance is further corrected according to the PV model parameters for the selected PV module to calculate the effective irradiance which is the irradiance *seen* by the actual PV cells. If a Project and model have not yet been created, SolSensor values do not receive this further correction, and *preliminary irradiance* values are shown. In this situation, the irradiance value displayed in the live SolSensor readings section on the right of the screen is rounded to the nearest 10W/m² and printed in italics.

Once the Project and model are created, the effective irradiance shows in normal font with a resolution of 1W/m². Expect to see slight differences between preliminary and effective irradiance based on the corrections. To see the measured (preliminary) irradiance with 1W/m² resolution go to the **Calibration Verification** dialog under the **Utility** menu. See [Calibration Verification](#).

SolSensor Precautions

Protect the Irradiance Sensor Element

When not in use, keep the irradiance sensor (white acrylic disc) covered by the supplied black rubber cover. Remove the cover after you mount SolSensor in the plane of the array, and replace the cover before you move SolSensor to another location.

 **Caution**

To avoid SolSensor damage, keep the cover on the irradiance sensor when not in use. The sensor is easily damaged by impact or abrasion, and accuracy is also compromised by soiling. The white acrylic eye of the irradiance sensor is a precision optical element which must be kept in new in condition to assure accurate measurements.

Diffuse Light

As sky conditions become hazy, a greater fraction of sunlight is scattered. This scattered or *diffuse* portion of the irradiance on the array from all directions and angles. It can be challenging for some irradiance sensors, depending on their construction, to accurately measure irradiance in the presence of significant diffuse irradiance. For example, some hand-held irradiance sensors have poor cosine response and their accuracy is specified only for direct normal irradiance, that is, clear days and pointed directly at the sun. A reference cell similar in technology to the cells of the modules under test reduces this error, but does not eliminate it. The SolSensor irradiance sensor is corrected for angular effects and results in better performance under diffuse light conditions.

Determine Irradiance from the Measured I-V Curve

Fluke recommends, in most cases, to use the SolSensor as the source of the irradiance measurement. However, there are certain times when it is useful to use the **From I-V** setting. When you select the **From I-V** option, the Software calculates irradiance from the measured I-V curve. This option has benefits and limitations.

From I-V option provides these benefits:

- There is no time delay between measurement of the I-V curve and determination of irradiance. This is helpful when irradiance changes rapidly (ramping) due to moving clouds, a condition under which any time delay between I-V and irradiance measurements translates into irradiance error.
- You can measure cell technologies that have a poor spectral match to the SolSensor silicon irradiance sensor.
- Since the predicted I_{sc} value is forced to agree with the measured I_{sc} value, it is easy to notice any deviations between the shapes of the measured and predicted I-V curves.

From I-V irradiance option also has these limitations:

- Uniform soiling is interpreted as reduced irradiance and thus does not cause a deviation between the measured and predicted I-V curves. Inspect the array before you measure, and clean it if needed to mitigate this risk.
- Similarly, uniform degradation of module I_{sc} is also interpreted as reduced irradiance, and thus is not detected.
- The **From I-V** irradiance value is used by the predictive PV model to calculate the expected value of I_{sc} . Using a measured value to calculate the expected value is circular, and forces the expected value of I_{sc} to agree with the measured value.

Enter the Irradiance Manually

When you select this option, manually enter an irradiance value obtained by another method such as a hand-held sensor or an array-mounted reference cell. This option has these limitations:

- Accurately orienting hand-held irradiance sensors in the plane of the array is difficult.
- A greater and more variable time delay between the I-V curve and irradiance measurements translates into irradiance error under conditions of rapidly changing irradiance.
- Hand-held irradiance sensors may have poor accuracy, especially in their cosine response. This introduces significant irradiance errors when the sun is off axis of the array and under diffuse light conditions.

Measure the Backside Temperature of a PV Module with a Thermocouple

Measurement of the module backside temperature is one of the traditional methods used by I-V curve tracers. It has several benefits and limitations. Note that some of the necessary items are covered in [Set Up and Use the I-V Curve Tracer and SolSensor](#).

The Backside Thermocouple method provides these benefits:

- It is a direct method with no dependence on a PV model.
- It enables you to choose the location for temperature measurement. It is best to choose an average temperature location and avoid locations that are much hotter or much closer to the cooler edges of the array.

The Backside Thermocouple method has these limitations:

- The predictive PV model wants to know the cell temperature, but the thermocouple measures the slightly cooler backside temperature. The Software partially compensates for this by modeling the temperature drop from cell to backside (adding up to 3 °C to the measured backside temperature). The amount of compensation varies in proportion to irradiance, since at high irradiance the difference between cell and backside temperature is higher.
- Backside temperature varies substantially across a PV module, string, or array. This variation is caused by patterns of convective cooling that depend on degree of ventilation, relative location in the array, and exposure to wind. For this reason, your temperature measurements can be biased higher or lower than actual.

Select a Thermocouple Wire Gauge

Fluke recommends the use of the thermocouples supplied with the SolSensor, but if you use a different thermocouple, choose a relatively fine thermocouple wire gauge, ideally #24 or #30. Some users prefer #24 for extra ruggedness and handle-ability.

There are various reasons to use one of these finer wire gauges:

- For accurate temperature measurements, the tip of the thermocouple must be kept in good physical contact with the backside surface. An air gap between the thermocouple and backside surface translates into a lower temperature reading. Typically, tape is used to hold the thermocouple in place. Stiff thermocouple wire is not compliant enough to allow the tape to do its job.
- Because heavier-gauge thermocouple wires are more massive, the thermocouple cannot respond as quickly to temperature variations caused by wind or changes in irradiance. Under changing conditions, a measurement delay translates to a measurement error.
- The thermocouple wires themselves drain a small amount of heat away from the tip of the thermocouple. This heat drain causes a slight temperature drop in the module backside material which has poor thermal conductivity.

Select a Thermocouple Tip

A variety of tip styles are available. The simple beaded tip is a good choice because it is rugged and reliable and has relatively low mass, that allows it to quickly track variations in temperature. Lower-mass tips with integral adhesive strips can also be used, but experience shows that these devices are easily damaged.

Measure PV Module Temperature with an Infrared Thermometer

Some measurement solutions rely on infrared measurements of module temperature. This approach has serious limitations.

Since the IR thermometer determines temperature by sensing radiant energy emitted by the object being measured, the accuracy of the temperature measurement depends on how closely the emissivity control setting of the instrument matches the actual emissivity of the object. The emissivity of a material is a measure of its relative ability to emit energy through radiation. It is the ratio of energy radiated by a particular material to energy radiated by a black body at the same temperature. A true black body would have an $\epsilon = 1$ while any real object would have $\epsilon < 1$. In general, the duller and blacker a material is, the closer its emissivity is to 1. The more reflective a material is, the lower its emissivity. Highly polished silver has an emissivity of about 0.02.

Some IR thermometers allow continuous adjustment for emissivity. Some models provide only a high/medium/low setting, which limits your accuracy. Some use a factory preset emissivity and are not user-adjustable.

PV module backsides do not all have the same emissivity, so you must either adjust the emissivity control of the instrument to match the backside surface or change the emissivity of the backside surface to match the instrument. Flat black electrical tape is commonly used to achieve high emissivity. With this technique, you can set the emissivity control at 1 and have reasonable accuracy.

If you do not use tape, you can calibrate your instrument against another measurement method, usually a thermocouple taped to the back of the same PV cell (see guidelines discussed earlier). Adjust the emissivity until the temperature indications are the same. Keep in mind that this emissivity setting is calibrated only for this particular type of module backside.

With infrared techniques, do not measure module temperature from the front side of the module. Glass reflects the heat of other objects, especially the sun. Also, the glass may not be completely transparent to the wavelength of the IR instrument. As a result, the temperature indication will be some function of both the glass temperature and the PV cell temperature.

Determine Cell Temperature from the Measured I-V Curve

When you select the **From I-V** option, the Software calculates the equivalent cell temperature from the measured I-V curve. This option has several benefits and several limitations, all due to the fact that since temperature is calculated mainly from the measured V_{oc} and the resulting temperature value is an input to the PV model, the model dot that represents V_{oc} is forced to agree with the measured value of V_{oc} .

From I-V temperature option provides these benefits:

- The temperature value that results represents the average cell temperature, which is what the PV model needs. The method properly accounts for temperature variation across the module or string under test.
- There is no time delay between measurement of the I-V curve and determination of temperature. This is helpful when module temperature changes rapidly, a condition under which a time delay translates into a temperature error. Rapid temperature changes can result from variable cloudiness and also from gusty wind.
- Since the predicted V_{oc} value (the right-hand red dot superimposed on the displayed I-V curve) is forced to agree with the measured V_{oc} value, it is easier to notice any deviations between the shapes of the measured and predicted I-V curves.

From I-V temperature option also has these limitations:

- The model by which temperature is determined from V_{oc} is valid only at relatively high irradiance. At low irradiance, there is substantial error in the derivation of temperature.
- If the PV source under test has one or more shorted or conducting bypass diodes, the Software calculates a lower-than-actual cell temperature. You can mitigate this risk by comparing V_{oc} values between strings or modules under test. Values should be fairly consistent. If a single string shows a deviation of more than about 10 V to 12 V, a bypass diode may be turned on or shorted.
- The From I-V cell temperature value is used by the predictive PV model to calculate the expected value of V_{oc} . Using a measured value to calculate the expected value is circular, and forces the expected value of V_{oc} to agree with the measured value.

Measure PV Module Backside Temperature with a Thermocouple

Fluke recommends the use of the SmartTemp setting and one or two thermocouples on the backside of a module. The SmartTemp method uses a blend of the **From I-V** and backside thermocouple methods, that takes best advantage of each while it avoids the biggest limitations of each. The blend changes as a function of irradiance:

- At irradiance values $<400\text{W/m}^2$, temperature is obtained from the backside thermocouple.
- At irradiance values $>800\text{W/m}^2$, temperature is calculated with the From I-V method.
- At irradiance values between 400W/m^2 and 800W/m^2 , the Software progressively shifts between the thermocouple and From I-V methods.

This strategy employs the From I-V method at high irradiance values where it is most accurate, and relies on the backside thermocouple at low irradiance values where there is a relatively small temperature offset between the module backside and cell.

If the Software detects a temperature difference of more than 5 °C between the thermocouple and From I-V methods, the Software switches to use just the thermocouple. This reduces the likelihood of temperature errors caused by a missing module or shorted bypass diode.

Interpret Measured I-V Curves

A PV module, string, or array has a characteristic curve of current versus voltage: the *I-V curve*. The I-V curve represents the family of current and voltage pairs at which the PV circuit can operate at the corresponding irradiance and temperature. The I-V Curve Tracer mathematical models predict the shape for this curve for thousands of different PV modules and configurations. Occasionally, the shape of the measured I-V curve deviates substantially from the shape predicted by the model. These deviations contain information about the performance of the PV System and provide important clues to troubleshoot performance issues. This section describes the most common patterns of deviation and identifies the most likely causes for these deviations.

Inputs to the PV Model

The modeling features of the I-V Curve Tracer predict the shape of the I-V curve for comparison with measured results. For the prediction to be valid, the inputs to the model must be valid. The model inputs are:

- PV model parameters stored in the Software
- Number of PV modules in series
- Number of PV modules or strings being measured in parallel
- Length and gauge of wire between the PV modules and the I-V Curve Tracer
- Irradiance
- PV cell temperature
- Array azimuth and tilt
- Latitude and longitude
- Date, time, time zone, and daylight savings information

I-V Curve Terminology

These abbreviations are used in this discussion:

I_{sc} Short circuit current

I_{mp} Max power current

V_{mp} Max power voltage

V_{oc} Open circuit voltage

PF Performance Factor (PF, %) = $100 * (\text{Measured } P_{max} / \text{Predicted } P_{max})$

FF Fill Factor = $I_{mp} * V_{mp} / (I_{sc} * V_{oc})$

Performance Factor

The Performance Factor is the most important figure of merit for PV array performance. Performance Factor is the measured maximum power value divided by the predicted (modeled) maximum power value. Its range is 0 % to 100 %.

The predicted maximum power value is determined by the PV model, which takes into account the current values of irradiance and temperature. This means that Performance Factor is meaningful over a range of irradiance and temperature. Like most array performance measurements, the comparison is more accurate if the irradiance levels are high. Performance measurements taken at less than 400W/m² irradiance are not good predictors of how the string performs at high irradiance.

If a PV string or module operates correctly and is not shaded, soiled, or age-degraded, and is measured at high irradiance, the measured Performance Factor will typically be in the range of 90 % to 100 %. If the irradiance is stable and the array temperature does not change rapidly, the measured I-V curves should be very consistent from string to string.

Fill Factor

The Fill Factor is a valuable measure of the squareness of the knee of the I-V curve. A more square knee indicates a greater ability to convert sunlight into electrical power. Fill factor is defined by three points on the I-V curve, as shown in [Table 18](#). The Fill Factor range is 0 to 1.0, and the closer the Fill Factor is to 1.0, the closer the shape of the I-V curve approaches a perfect rectangle. Each PV technology has its own nominal range of fill factor values, and each module model number typically has a narrow nominal range.

Fill Factor does not vary much with irradiance so long as the irradiance is high, which means that a comparison of Fill Factor values is a good way to assess the consistency of I-V curve shapes in variable (but high) irradiance situations.

Table 18. Definition of the Fill Factor

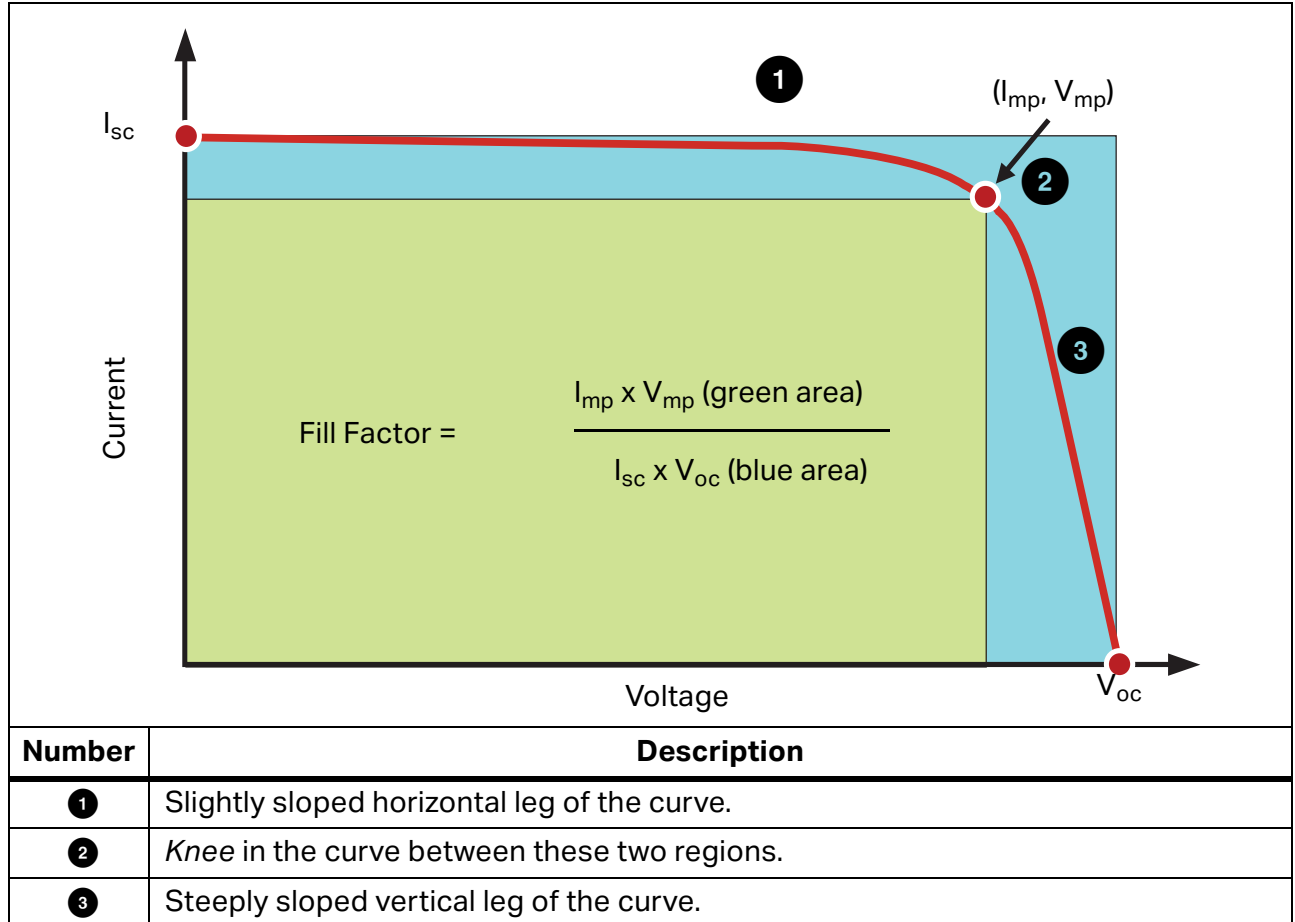

The Shape of a Normal I-V Curve

Table 19 shows a normal I-V curve (solid red line), as a start point for this discussion. The predicted I-V curve shape, determined by the PVA built-in PV model, is shown by the three red dots that represent I_{sc} , (I_{mp}, V_{mp}) , and V_{oc} . The I-V curve represents the entire family of points at which the PV circuit could be operated at the measured irradiance and temperature.

A normal I-V curve has a smooth shape with three distinct sections, see Table 18.

In a normal curve, the three sections are smooth and continuous. The shape and location of the knee depends on cell technology and manufacturer.

The three PV model points are defined, from left to right in Table 18, as follows:

1. I_{sc} - First point, at the predicted short circuit current I_{sc} .
2. M_{pp} - Second point, the predicted maximum power point I_{mp}, V_{mp} .
3. V_{oc} - Third point, at the predicted open circuit voltage V_{oc} .

Interpret I-V Curves

PV module or string performance problems cause deviations between the measured and predicted I-V curves. There are six distinct types of deviation, listed below and in [Table 19](#). A given PV source under test may show no deviation, one deviation, or a combination of two or more deviations.

Each of the I-V curve deviations illustrated in [Table 19](#) have multiple possible causes.

Note

Deviations from the predicted IV curve can be due to physical problems with the PV array under test or the result of measurement problems such as incorrect model values, instrument settings, or measurement connections. To minimize measurement problems, be sure to select the correct PV module from the on-board PV module list, double check the measurement connection, and ensure that irradiance measurements are taken in the plane of the array and are as simultaneous with the I-V sweep as possible.

Small deviations between the measured and predicted I-V curves are common given the uncertainty associated with the irradiance and temperature measurements and the fact that PV modules, even of a given manufacturer and model number, are not all identical. Shading and soiling also have effects not taken into account in the PV model.

Potential causes of substantial deviations between measured and predicted I-V curves are discussed below.

Table 19. Deviations in the Shape of the I-V Curve

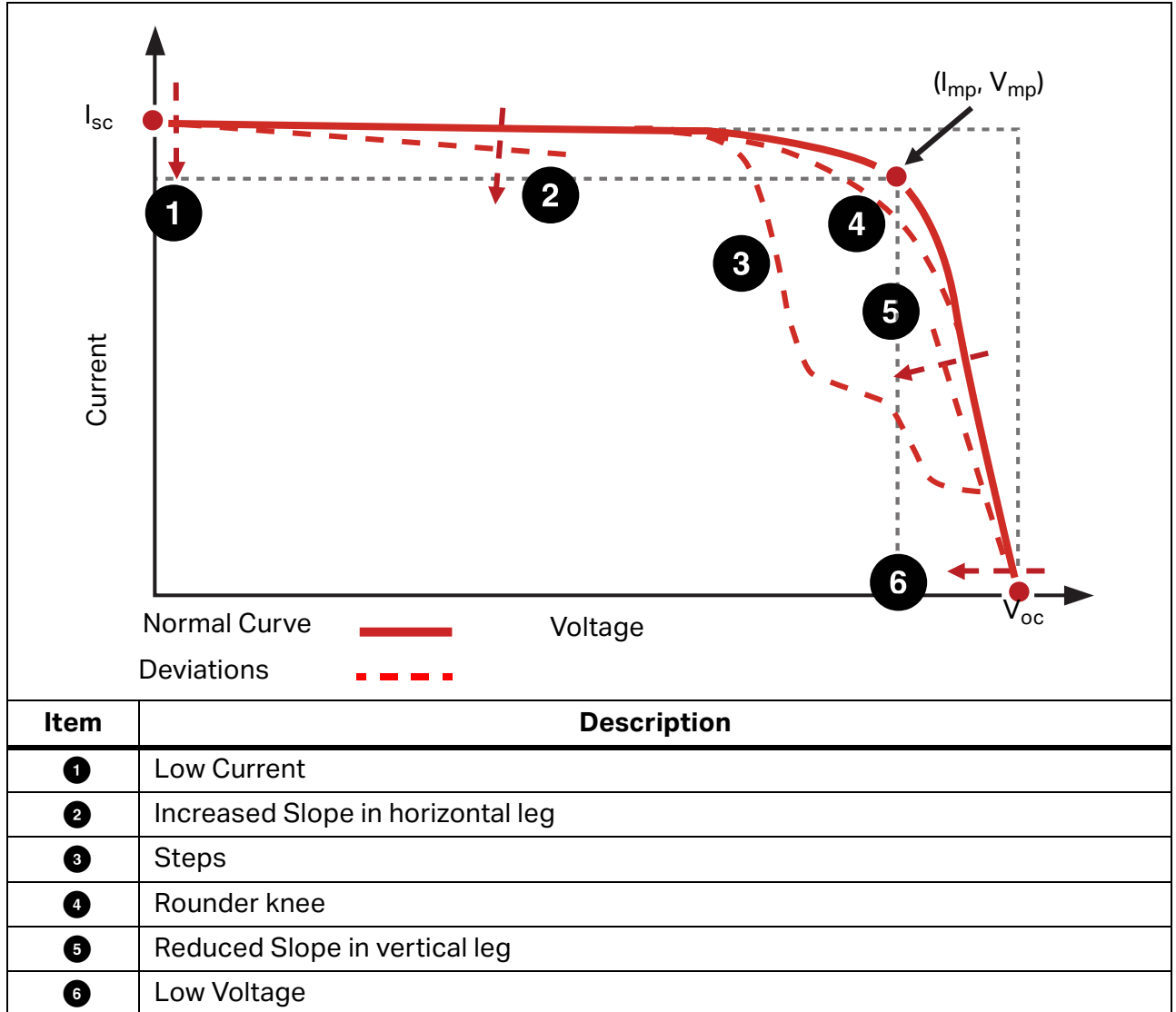

Notches or Steps

Array Is Partially Shaded, or Non-uniform Soiling, or Debris is Present

Examples of this type of deviation are shown in [Figure 15](#), [Figure 16](#), and [Figure 17](#).

Figure 15. The Effect of Partial Shading on a String I-V Curve

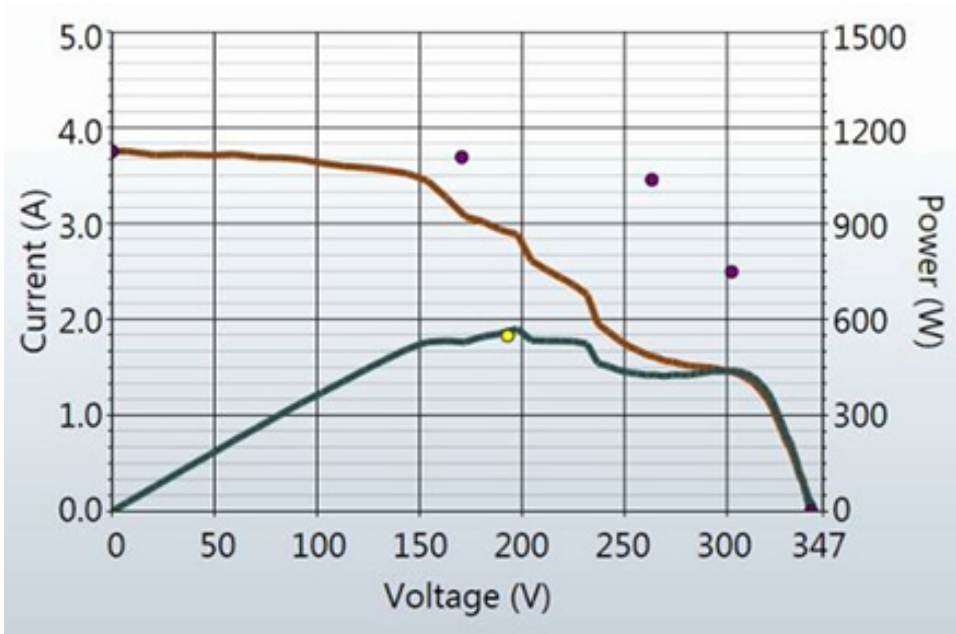
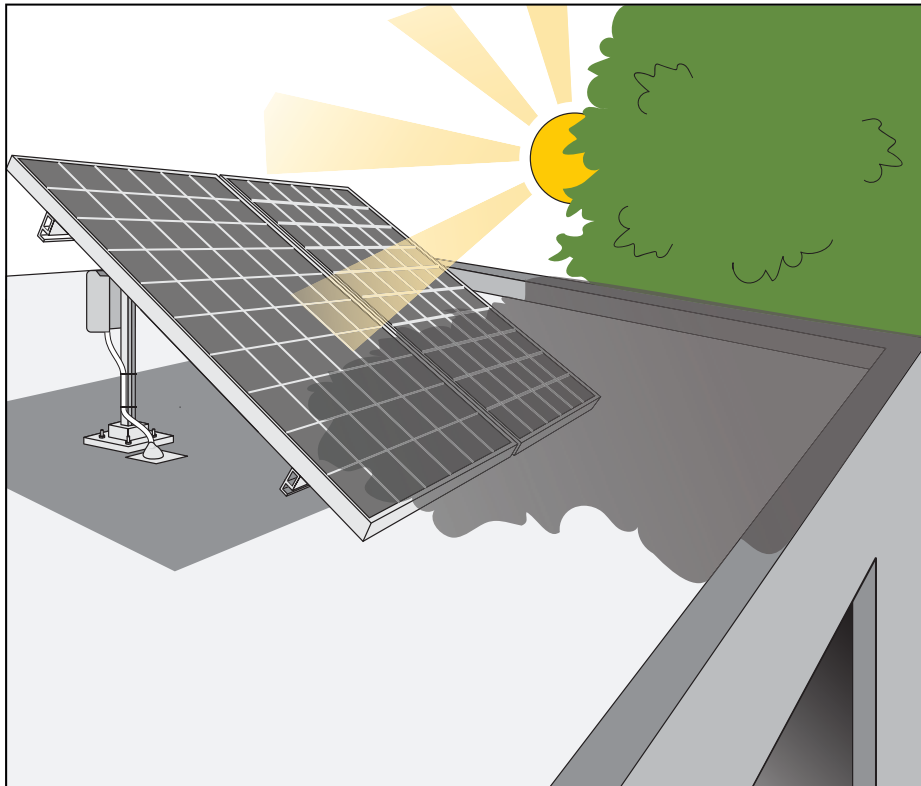

Figure 16. Shading Impact of a Business Card Placed on a Single Cell in a String of 15 180-watt Modules.

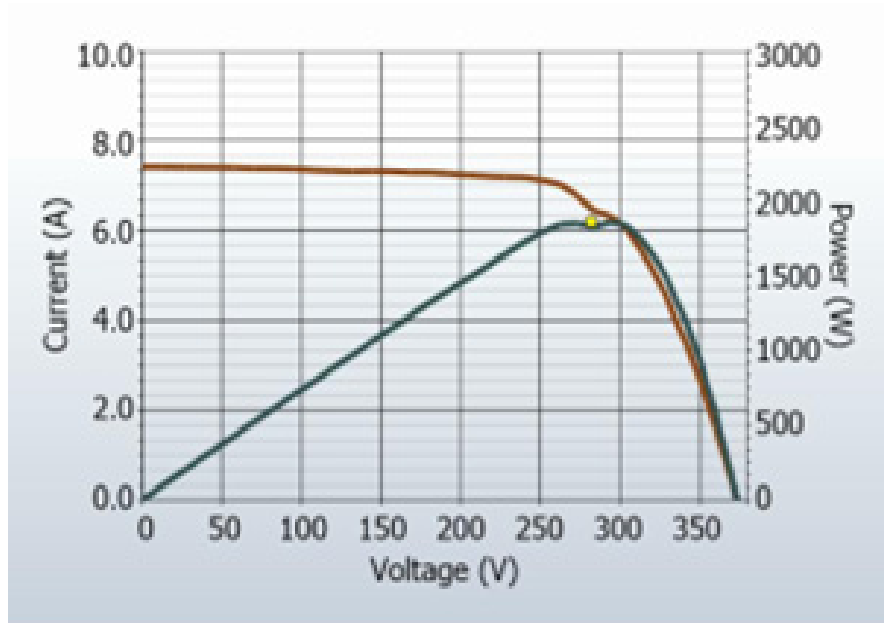
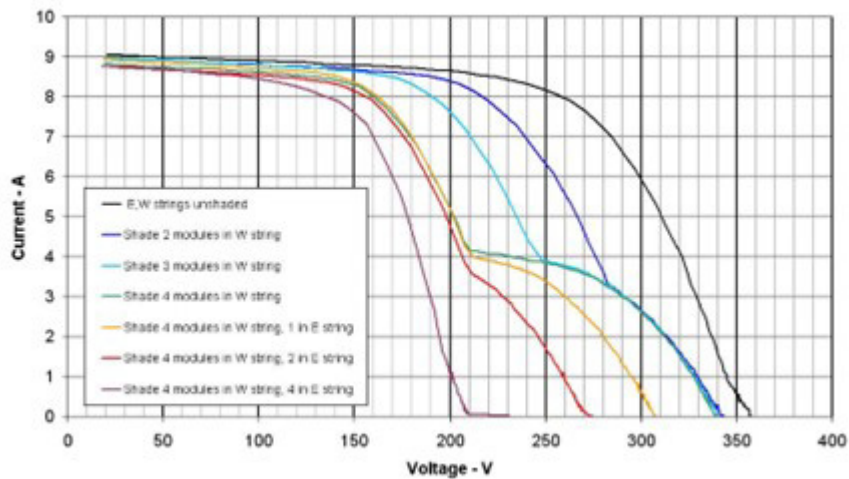

Figure 17. Effect of Shading Entire Modules in Different Combinations



In single-string measurements, steps indicate current mismatch between the modules (or cell groups within modules) of the string under test. Although the figures shown above involve shading, mismatch can have other causes. The notches in the I-V curve are associated with conduction of bypass diodes that protect individual cell groups within modules that are not able to pass the full current of the stronger modules and cell groups.

Potential causes of steps in the I-V curve are summarized below, and then discussed in more detail:

- Array is partially shaded, or non-uniformly soiled, or debris is present.
- A mix of different PV module specs within the same string.
- PV cells are damaged.
- Bypass diode is short-circuited (only if measuring strings in parallel).

Partial shading of a PV cell reduces the current capacity of that cell, which, if there were no bypass diodes, would limit the current in the entire string to that level. For example, slightly shading one cell in a 72 cell, 3-bypass diode module causes that cell bypass diode to conduct enough current to maintain string current, and avoid damage to the weak cell. Without the bypass diode present, the weak cell becomes reverse biased, which could generate potentially damaging reverse breakdown voltage and hotspot failure. The impact of partial shading on the I-V curve is to create a notch. In a single PV string, the depth of the step from normal I-V curve height indicates the severity of the current mismatch, and the width of the step indicates how many cell groups are involved.

PV Cells Are Damaged

There are cell-level failure modes that can reduce the ability of a cell to produce current. Also, cracks in the cell can electrically isolate sections of the cell. This has the same effect on the I-V curve as shading of an equivalent area of a normal cell.

Low Current

This section lists potential causes for the measured I_{sc} being higher or lower than predicted.

Uniform Soiling

The effect of uniform soiling is as if a window screen is pulled over the PV modules. The overall shape of the I-V curve is correct, but the current at each voltage is reduced.

Dirt Dam

A constant-width band of dirt across an entire string can also reduce current. The most common example is a low-tilt array with modules in portrait orientation. Over time, a band of dirt collects at the lower edge of each module. When the band of dirt reaches the bottom row of cells, it begins to limit current. If the dirt bands are similar enough from module to module, the effect is like uniform soiling.

Module Degradation

Degradation of PV module performance with time and environmental stress can reduce the current. Degradation is normally a slow process. Be sure to rule-out measurement technique-related factors that can affect the height of the I-V curve, before you conclude that the modules have degraded.

Incorrect PV Module Is Selected for the PV Model

PV modules with similar PV model numbers may have different I_{sc} specifications. Check that the module selected from the on-board module list matches the nameplate on the back of the PV modules. If the array is known to have a mix of PV modules of different types, this can contribute to changes in I_{sc} . Mixed modules can also cause a mismatch effect, another class of deviation.

Number of PV Strings in Parallel Is Not Entered Correctly in the Model

The measured value of I_{sc} scales directly with the number of strings in parallel. Check that the correct value is entered into the model, and that the measurement was saved to the correct branch of the array tree.

Irradiance Changed Between Irradiance and I-V Measurements

The time delay between the irradiance measurement and the I-V measurement can translate into measurement error. The error is greatest when the sky conditions are not stable (for example, partially cloudy) and a manual irradiance sensor is in use. The process to orient the manual sensor, noting the value, and entering the value into the PVA software takes much more time than the automated process used by SolSensor.

Irradiance Sensor Is Not Oriented in the Plane of Array

The accuracy of the irradiance measurement is extremely sensitive to the orientation of the sensor. The I-V Curve Tracer model assumes that the irradiance sensor is oriented in the plane of the array. It is difficult to consistently position hand-held sensors in the plane of the array. To see how much error this can introduce, orient the sensor to match the plane of the array and note the irradiance value. Then remove the sensor and repeat several times within a minute, and examine the consistency of the recorded values. This experiment works only under stable irradiance conditions.

Albedo Effects (Reflection)

The energy production of PV modules can be increased by reflection or scattering of light from nearby buildings, automobiles, and other surfaces (the Albedo effect).

PV arrays and irradiance sensors can pick up significant amounts of irradiance reflected off of surrounding surfaces. Examples of albedo effects include reflections from adjacent roof surfaces, building walls, and other PV arrays. The strength of the albedo effect is not as much a function of the perceived color of the surface as one might think. Even the surface of a blacktop parking lot reflects substantially.

If the array under test is located in a built-up environment with lots of reflective surfaces, there is not much you can do about it, other than to select an irradiance sensor location that represents the typical irradiance conditions. Of course, the I-V curve measurements register the albedo effects. This is another reason to conduct important performance measurements in the central 4 hours of the day when albedo effects are likely to be minimized in relation to the direct irradiance.

Manual Irradiance Sensor Is Not Accurate

Hand-held irradiance sensors vary widely in their calibration accuracy, response to off-angle light, and spectral match to the array measured. All of these variables affect accuracy.

Low Voltage

An example of this type of deviation is in Figure [Figure 18](#).

Figure 18. Measurement with a Lower than Predicted Voc

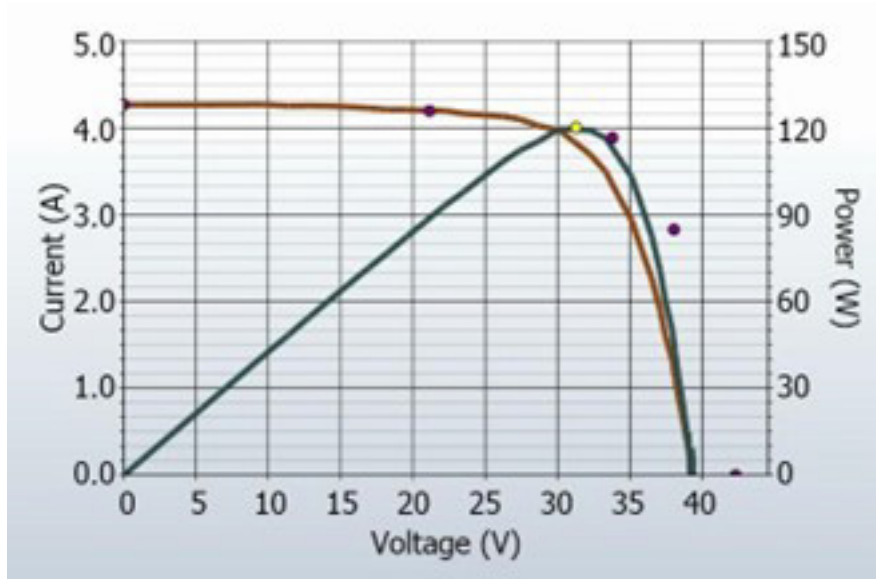

PV Cell Temperature Measurement Is Incorrect

The module V_{oc} depends on the temperature of the solar cells. Higher temperatures result in a lower V_{oc} . It is possible that a poor thermal connection exists between the thermocouple and the back of the module leading to a temperature measurement error.

Also, if two thermocouples are plugged into SolSensor and only one of them is attached to the back of a module this can cause a temperature measurement error because, the Software averages the two thermocouple temperatures.

Placement of the thermocouple is also important. It should be placed at a location that represents the average temperature of the modules. Avoid the edges of the table/array because they run cooler due to better air circulation.

One or More Bypass Diodes Are Shorted

This is a possible cause in single-string measurements. In parallel-string measurements it causes a step in the I-V curve.

Rounder Knee

An example of this type of deviation shows in [Figure 19](#).

Figure 19. I-V Curve Measurement of Rounder Knee than Predicted by the PV Model

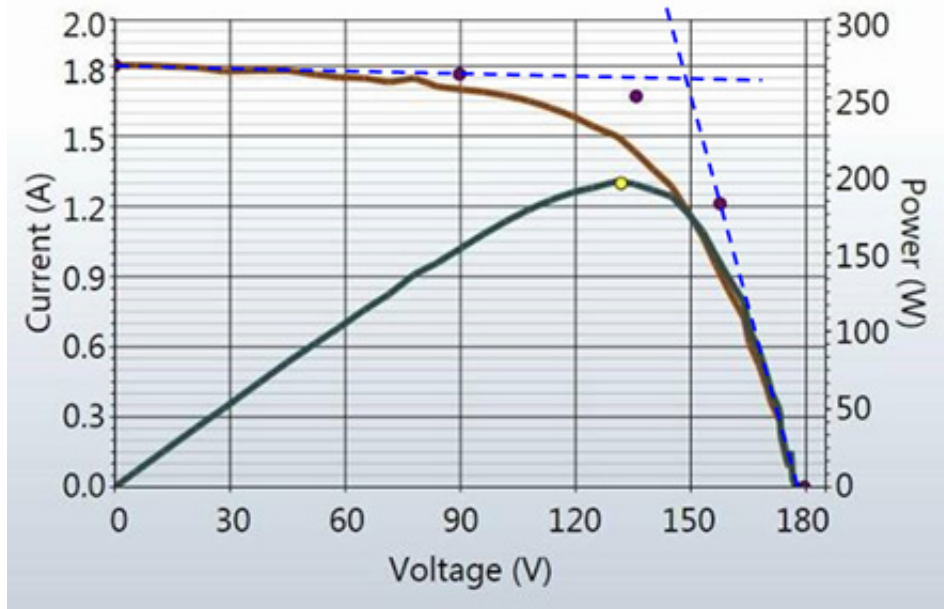

Rounding of the knee of the I-V curve can be a manifestation of the aging process. This effect is rarely seen alone, and is usually a side-effect of changes in the slopes of the legs of the curve.

Steeper Slope in Horizontal Leg

An example of this deviation is shown in [Figure 20](#).

Figure 20. I-V Curve with a Steeper Slope in the Horizontal Leg of the I-V Curve

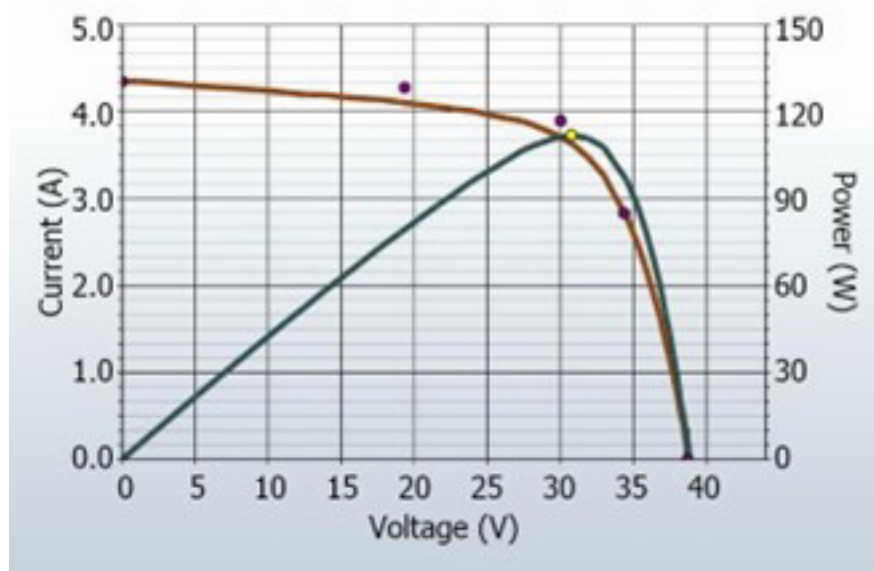

The horizontal leg of the I-V curve may exhibit a steeper slope than the PV model predicts. Potential causes of this deviation are summarized below, and then discussed in more detail:

- Tapered shade or dirt dams
- Module I_{sc} mismatch
- Shunt paths exist in PV cells

Tapered Shade or Dirt Dam Across All Cell Groups

A tapered band of shade or dirt across the all cell groups can cause the steeper slope in the horizontal leg of the curve.

Increased Shunting in PV Cells

Shunting is the flow of PV current backwards across the cell junction. This is a current loop internal to the cell, which subtracts from the current that it is able to contribute to the string. Some amount of shunt current within a solar cell is normal, and is the cause of the slight slope in the horizontal leg of the curve. However, if the shunt resistance of cells degrades to a lower value across the array, the slope of the horizontal leg becomes steeper.

Localized shunt failures cause local heat dissipation and can lead to runaway thermal failures of the cell and module.

Less Steep Slope in Vertical Leg

An example of this type of deviation is shown in [Figure 21](#).

Figure 21. Measurement with Less Steep Slope in the Vertical Leg of the I-V Curve

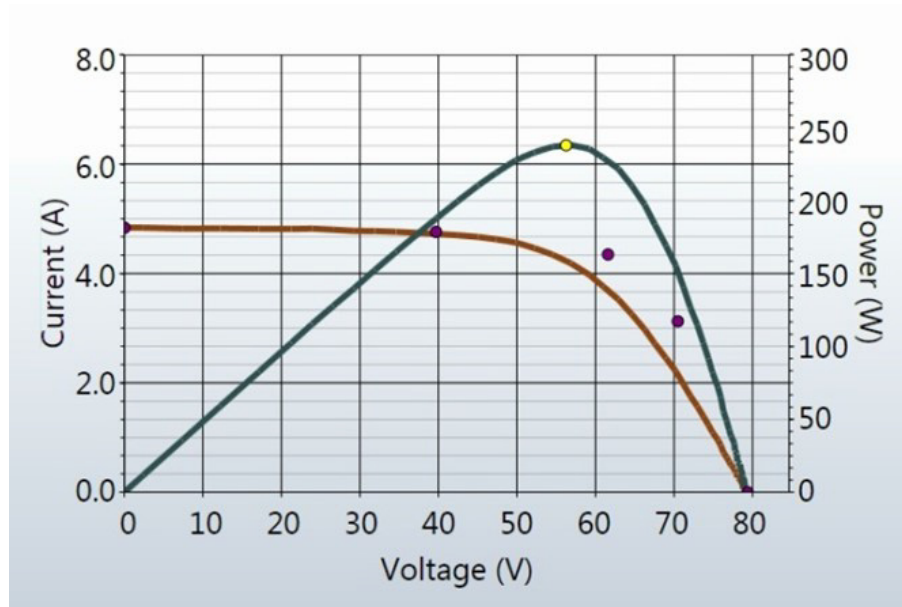

The slope of the vertical leg of the I-V curve is affected by the amount of series resistance internal to the PV modules and in the array wiring. Increased resistance reduces the steepness of the slope and decreases the fill factor.

Potential causes are summarized below, and then discussed in more detail:

- PV wiring has excess resistance or is insufficiently sized.
- Electrical interconnections in the array are resistive.
- Series resistance of PV modules has increased.

PV Wiring Has Excess Resistance

During setup of the Project in the Software, the user enters the length and gauge of the external, string-related wiring, most commonly the home-run cabling to a combiner box. During measurements, the PV model uses this information to account for expected voltage and power loss in this external wiring, so that it is not associated with the performance of the PV modules. The wire length does not include the length of the cords of the modules themselves. A major difference between entered and actual wire length can introduce excess resistance. For example, 500 ft (1-way) of #10 wire will add approximately 1 Ω of series resistance. This would reduce the slope in the vertical leg of the predicted I-V curve near V_{OC} .

The resistance of the test leads of the I-V Curve Tracer is extremely low and can be neglected.

Electrical Connections in the Array Are Resistive

Electrical connections anywhere along the current path can add resistance to the circuit. Assure that connectors between modules are fully inserted. Also check for signs of corrosion in J-boxes and combiners.

Series Resistance of PV Modules Has Increased

Certain degradation mechanisms can increase the amount of series resistance of a particular module. Corrosion of metal terminals in the module connectors, in the module junction box, or on the interconnects between cells may increase series resistance.

Troubleshoot PV Arrays

For a detailed article on how to interpret I-V curve deviations, see the SolarPro article, *Solar I-V Curves--Interpreting Trace Deviations*.

Translation of I-V Data to Standard Test Conditions

The Software provides a feature to translate the displayed I-V curve to Standard Test Conditions (STC) of 1000W/m² and 25 °C. The Software also translates the key performance parameters in the **Table** view (tab).

The primary application for these features is the analysis of I-V data collected during the commissioning of commercial scale PV arrays. As these measurements are usually done in a 4-hour span centered about solar noon, the measured I-V curves reflect the changes in irradiance and cell temperature that take place over this time period. The translation features remove these effects to a first order by translating key performance parameters derived from the I-V curves to STC conditions. Fast changes in irradiance and temperature caused by rapidly moving clouds will be difficult to correct accurately, so clear days are still required for quality end results.

Translation introduces error in proportion to the span of the translation. Take this into account when you assess the consistency of performance across a population of PV strings.

Parameter Definitions

These definitions are extracted from the Sandia PV Array Model (D. L. King) paper:

I_{sc} = Short-circuit current (A)

I_{mp} = Current at the maximum-power point (A)

V_{mp} = Voltage at maximum-power point (V)

V_{oc} = Open-circuit voltage (V)

P_{mp} = Power at the maximum power point (W)

$\alpha_{I_{sc}}$ = Normalized temperature coefficient for I_{sc} , (%/°C). This parameter is *normalized* by dividing the temperature dependence (A/°C) measured for a particular standard solar spectrum and irradiance level by the module short-circuit current at the standard reference condition, I_{sc0} . Using these (%/°C) units makes the same value applicable for both individual modules and for parallel strings of modules.

$\alpha_{I_{mp}}$ = Normalized temperature coefficient for I_{mp} , (%/°C). Normalized in the same manner as $\alpha_{I_{sc}}$.

$\beta_{V_{oc}}$, (%/°C) = Temperature coefficient for module open-circuit-voltage.

$\gamma_{m_{pp}}$, (%/°C) = Temperature coefficient for module maximum power point voltage.

T_c = Cell temperature inside module in °C. Obtained by measuring the back-surface module temperature and adding the temperature differential (typically 2 degrees to 3 degrees, depending on irradiance levels).

Translation Equations

The basic translation model used here makes these approximations:

P_{mp} is proportional to E, the irradiance

I_{mp} does not depend on temperature

V_{mp} is independent of E

P_{mp} varies with temperature according to γ_{mpp} . (taken from the data sheet)

V_{oc} is independent of E

In light of these approximations, we make these assumptions:

I_{sc} scales directly with E and with temperature.

V_{oc} varies linearly with temperature according to β_{Voc} .

P_{mp} scales with E and varies with temperature according to γ_{mpp}

V_{mp} changes with temperature depending on γ_{mpp} only, since α_{Imp} is much smaller than α_{Isc} and is assumed to be zero.

The translation equations are as follows, where the subscripts are defined as m = measured, and trans = translated:

$$I_{sctrans} = I_{scmeas} * (E_{trans} / E_{meas}) / (1 + (\alpha_{Isc}/100) * (T_{meas} - T_{trans}))$$

$$V_{octrans} = V_{ocmeas} / (1 + (\beta_{Voc}/100) * (T_{meas} - T_{trans}))$$

$$I_{mptrans} = I_{mpmeas} * (E_{trans} / E_{meas})$$

$$V_{mptrans} = V_{mpmeas} / (1 + (\gamma_{mpp}/100) * (T_{meas} - T_{trans}))$$

$$P_{mptrans} = P_{mpmeas} * [E_{trans} / E_{meas}] / (1 + (\gamma_{mpp}/100) * (T_{meas} - T_{trans}))$$

Maintenance

Clean the Product

Caution

To prevent Product damage, do not use solvents or cleaners. These fluids can damage the Product.

To clean the I-V Curve Tracer, SolSensor outer case, and test leads wipe them with only a damp cloth and mild detergent.

Clean the SolSensor Irradiance Sensor

Caution

To prevent irradiance sensor damage, do not use solvents or cleaners to clean the sensor. These fluids can cause micro-cracks in the material and reduce the accuracy of the irradiance measurement. Use only distilled water and a soft cloth. A soft microfiber cloth and a spray bottle of distilled water are supplied as standard equipment.

To clean the irradiance sensor:

1. Tip the SolSensor unit on its side so that the irradiance sensor faces horizontally.
2. Spray the white acrylic disc with a fine mist of distilled water.
3. Let the excess water run off, carrying dust and dirt with it.
4. Dry the white acrylic disc with a soft, clean, dry cloth. Never use soap or chemical solutions or abrasive cloths.

Product Disposal

Dispose of the Product in a professional and environmentally appropriate manner. If this Product has an integral battery, put the entire Product in the electrical waste.

Troubleshoot PVA Software Operation

This section describes steps to troubleshoot the operation of the Software. Troubleshooting of actual PV systems is not included in this discussion.

For tips to set up Windows for compatibility with the Software, and to troubleshoot Windows, see the product page on the Fluke website.

Troubleshoot with Status Messages

The main tool to troubleshoot Software operation is the Status indicator, shown on the upper right of the screen above the **Measure Now** button. See the green **Ready** message in [Table 7](#) for an example. See [Table 20](#).

 **Warning**

To prevent possible electrical shock, fire, personal injury, or death, pay attention to the Status indicator in the upper right of the Software. Click on the Status indicator in any state to get more information about the status. Note that the PV circuits continue to present danger of electrical shock regardless of the active, paused, or disabled state of the I-V Measurement Unit.

Table 20. Status Messages

Status Message	Description
Ready	The wireless link to the I-V Curve Tracer is established and the equipment can now take a measurement.
Initializing	The link to the I-V Curve Tracer is established, and the Software is initializing the device.
Measuring	The I-V Curve Tracer is currently processing a measurement request and performing an I-V measurement.
Disabled	<p>The I-V Curve Tracer has turned itself off because it detected one of these conditions listed below. Click the Disabled message and follow the instructions. See Software Overview.</p> <p>I-V Measurement Unit battery voltage is too low: The battery level is critically low, and the I-V Curve Tracer will now shut down. Recharge the battery before further use.</p> <p>Current in excess of xxA was detected: The maximum input current specification has been exceeded. If you will measure strings in parallel, reduce the number of parallel strings.</p> <p>Excess voltage was detected: Voltage specification was exceeded. If the overvoltage is severe, the Software also permanently disables the I-V Curve Tracer. This condition requires the I-V Curve Tracer to be returned to the factory for inspection and repair.</p> <p>I-V Measurement Unit is too hot: I-V Curve Tracer internal temperature is too high and the protection circuit has shut it down. Move the I-V Curve Tracer to a cooler location out of the direct sun, and allow time for the temperature to drop.</p> <p>Current overload pulse: A significant current overload pulse was detected. Make sure the inverter or other parts of the array were not inadvertently connected during the measurement. Also, certain high efficiency PV modules generate a high in-rush current. When you use the PVA-1500T2, do not measure these types of modules in parallel or strings of high efficiency modules that are >10 A.</p>

Table 20. Status Messages (cont.)

Status Message	Description
Paused	The I-V I-V Curve Tracer has been temporarily stopped because you pushed the LED button. It is a normal part of the operation of the I-V Curve Tracer. In this condition, PV source connections may be changed without interruption to a measurement. To return to the normal state, push the LED button again.
Searching for I-V Unit	The PC and Software has not yet connected with the Wi-Fi hotspot created by the I-V Curve Tracer. The I-V unit LED button blinks rapidly when it is not connected to the PC software with Wi-Fi. Make sure that the I-V unit is turned on and is within wireless range.
No WiFi connection	The PC Wi-Fi network adapter is turned off. Turns on the Wi-Fi adapter and connect to the PVA1500_yyyyyy hotspot.

Troubleshoot by Symptom

Table 21 shows symptoms and steps to troubleshoot the issue.

Table 21. Troubleshoot By Symptom

Symptom or Message	Description and Remedy
SolSensor display area says searching for SolSensor or shows ----	<p>With the SolSensor, these messages appear in the SolSensor data display area when the SolSensor does not have a wireless link to the I-V Unit. Make sure the SolSensor is on and that it is within wireless range. Obstructions in the line-of-sight can reduce wireless range.</p> <p>If the SolSensor continues to fail to connect, perform a hard reset of the SolSensor and the I-V Unit. Hold down the power button for at least 6 seconds on each.</p> <p>It is also possible that the SolSensor is not properly paired to the I-V unit. The SolSensor units are paired at the factory to the specific I-V unit that ships with your SolSensor. If you have a new SolSensor that was never paired to your I-V unit, or it has lost its pairing, it may be re-paired to the I-V unit with the steps in Operational States of the Table 3.</p>
Communication to I-V Measurement Unit or SolSensor Briefly Drops Out	A brief dropout can occur between the I-V Curve Tracer and PC. If the link does not restore in 2 minutes, you may be out of wireless range. Similarly, communication with SolSensor can also briefly drop out, but should restore momentarily if SolSensor and the I-V Curve Tracer are within wireless range of one another. If the I-V Unit is not wirelessly connected to the PC, the software shows Searching for SolSensor because SolSensor communicates through the I-V Curve Tracer to the PC.

Table 21. Troubleshoot By Symptom (cont.)

Symptom or Message	Description and Remedy
Measurements Take Longer to Save	<p>The measurement save speed depends on the number of I-V trace points selected. Use 100 points for most work and 500 points when high resolution is required. The resolution can be changed back and forth any time throughout your Project. The resolution control is located in the Utility menu.</p> <p>The minimum time from measurement to measurement for the I-V Curve Tracer is also affected by the open circuit voltage of the strings under test. See Table 5.</p>
I-V Curve Does Not Reach Down to the X-axis	<p>This type of trace may be seen if you have been measuring an I-V curve with a large step in the current.</p>
Trace is Noisy	<p>Noisy I-V curve traces can be a result of low irradiance, especially for PV technologies with low short circuit current. For best results, make measurements of fixed arrays during the hours of maximum irradiance. Strings of low I_{sc} modules can be tested in parallel to increase current and reduce noise. In rare occasions, current spikes can appear in the I-V curve data, especially near V_{oc}. This can indicate a problem in the modules or wiring such as an arc fault.</p>
I-V Curve Drops to Zero Current at One or More Points	<p>This condition can occur if there is an unstable electrical connection in the PV circuit being measured. This is not a problem with the I-V Curve Tracer. In stages, remove modules and cables from the PV source circuit to locate the unstable connection.</p>
Short Circuit Current is Much Higher, or Lower, than Predicted by the Model	<p>Make sure the irradiance sensor is mounted in the plane of the array. Check for array soiling. Make sure that the latitude, longitude, and azimuth are correctly entered on the Site Info screen, and that the PC date and time are correct. If you use a tracker, make sure the morning array azimuth is set correctly in the Site Properties of the PVA project in the Software.</p>

Table 21. Troubleshoot By Symptom (cont.)

Symptom or Message	Description and Remedy
Unstable Voltage Message	Before you do a sweep, the PVA measures V_{oc} 10 times to get an average value. If there is a large variation of values across these 10 measurements, the Software posts a warning. Check for poor connections anywhere in the measurement loop.
I-V Curve Tracer Cannot be Turned On	Check that the I-V Curve Tracer is charged.
Zero Current for Entire I-V Curve	The I-V Curve Tracer contains a thermal fuse set to trip if the inside of the I-V Curve Tracer exceeds 85 °C. This is an uncommon occurrence because the software is programmed to dis-allow measurements when the internal temperature exceeds approximately 72 °C. However, if the thermal fuse trips, it irreversibly shuts down the I-V Curve Tracer and requires a return to the factory. If you suspect that this has occurred, contact Fluke. See Contact Fluke .

For further troubleshooting information, see the poster that shipped with the Product that is also available at fluke.com.