

**FLUKE®**

**9040**

*Phase Rotation Indicator*

**Users Manual**

PN 2438546

April 2005, Rev. 3, 11/21

© 2005-2021 Fluke Corporation. All rights reserved. Specifications are subject to change without notice.

All product names are trademarks of their respective companies.

## LIMITED WARRANTY AND LIMITATION OF LIABILITY

This Fluke product will be free from defects in material and workmanship for one year from the date of purchase. This warranty does not cover fuses, disposable batteries, or damage from accident, neglect, misuse, alteration, contamination, or abnormal conditions of operation or handling. Resellers are not authorized to extend any other warranty on Fluke's behalf. To obtain service during the warranty period, contact your nearest Fluke authorized service center to obtain return authorization information, then send the product to that Service Center with a description of the problem.

THIS WARRANTY IS YOUR ONLY REMEDY. NO OTHER WARRANTIES, SUCH AS FITNESS FOR A PARTICULAR PURPOSE, ARE EXPRESSED OR IMPLIED. FLUKE IS NOT LIABLE FOR ANY SPECIAL, INDIRECT, INCIDENTAL OR CONSEQUENTIAL DAMAGES OR LOSSES, ARISING FROM ANY CAUSE OR THEORY. Since some states or countries do not allow the exclusion or limitation of an implied warranty or of incidental or consequential damages, this limitation of liability may not apply to you.

Fluke Corporation  
P.O. Box 9090  
Everett, WA 98206-9090  
U.S.A.

Fluke Europe B.V.  
P.O. Box 1186  
5602 BD Eindhoven  
The Netherlands

## ***Table of Contents***

<b>Title</b>	<b>Page</b>
Introduction.....	1
How to Contact Fluke.....	1
Unpacking the 9040.....	2
Safety Information.....	3
Symbols.....	5
Elements of the 9040.....	7
Determine the Rotary Field Direction.....	8
Maintaining the 9040.....	9
Replacing the Fuse (9040UK only).....	10
Specifications.....	11



## ***Introduction***

The Fluke 9040 Phase Rotation Indicator (the 9040 or the Product) is a handheld instrument designed to detect the rotary field of three-phase systems.

## ***How to Contact Fluke***

Fluke Corporation operates worldwide. For local contact information, go to our website:  
[www.fluke.com](http://www.fluke.com)

To register your product, view, print, or download the latest manual or manual supplement, go to our website.

Fluke Corporation  
P.O. Box 9090  
Everett, WA 98206-9090  
+1-425-446-5500  
[fluke-info@fluke.com](mailto:fluke-info@fluke.com)

## **Unpacking the 9040**

The 9040 is available in three configurations. Depending on your purchase, the 9040 ships with these items:

- **9040**
  - 3 self-retaining test probes, 1000 V CAT II
  - 3 alligator clips, 1000 V CAT III/600 V CAT IV
  - Users Manual
- **9040UK**
  - 3 fused test probes, 1000 V CAT III
  - 3 alligator clips, 1000 V CAT III/600 V CAT IV
  - Users Manual
- **9040EUR**
  - 3 Slim-Reach™ test probes (black) 1000 V CAT III/600 V CAT IV
  - 3 self-retaining test probes, 1000 V CAT II
  - 3 alligator clips, 1000 V CAT III/600 V CAT IV
  - Users Manual

### **Warning**

**To prevent possible electrical shock, fire, or personal injury, do not exceed the Measurement Category (CAT) rating of the lowest rated individual component of a product, probe, or accessory.**

If an item is damaged or missing, contact the place of purchase immediately.

## **Safety Information**

**Caution** identifies conditions and actions that may damage the 9040.

**Warning** identifies conditions and actions that pose hazard(s) to the user.

### **Warning**

**To prevent possible electrical shock, fire, or personal injury:**

- **Read all safety information before you use the Product.**
- **Carefully read all instructions.**
- **Use this Product indoors only.**
- **Use only current probes, test leads, and adapters supplied with the Product.**
- **Do not use the Product above its rated frequency.**
- **Do not apply more than the rated voltage, between the terminals or between each terminal and earth ground.**
- **Do not keep the Product in operation and unattended at high temperatures.**

- **Comply with local and national safety codes. Use personal protective equipment (approved rubber gloves, face protection, and flame-resistant clothes) to prevent shock and arc blast injury where hazardous live conductors are exposed.**
- **Use the product only as specified, or the protection supplied by the product can be compromised.**
- **Do not work alone.**
- **Do not use test leads if they are damaged. Examine the test leads for damaged insulation or exposed metal. Check test lead continuity.**
- **Do not touch voltages >30 V ac rms, 42 V ac peak, or 60 V dc.**
- **Keep fingers behind the finger guards on the probes.**
- **Measurements can be adversely affected by impedances of additional operating circuits connected in parallel or by transient currents.**
- **Verify operation prior to measuring hazardous voltages (voltages above 30 V ac rms, 42 V ac peak and 60 V dc).**
- **Do not use the 9040 with any of the parts removed.**
- **Do not use the product around explosive gas, vapor, or in damp or wet environments.**

## **Symbols**

The following symbols appear on the 9040 or in this manual.

**Table 1. Symbols**







	WARNING. RISK OF DANGER.		Earth ground.
	Hazardous voltage. Risk of electric shock.		Double Insulated.
	Consult user documentation.		Conforms to requirements of European Union.
<b>CAT II</b>	Measurement Category II is applicable to test and measuring circuits connected directly to utilization points (socket outlets and similar points) of the low-voltage MAINS installation.	<b>CAT III</b>	Measurement Category III is applicable to test and measuring circuits connected to the distribution part of the building's low-voltage MAINS installation.

Table 1. Symbols (cont.)

<b>CAT IV</b>	Measurement Category IV is applicable to test and measuring circuits connected at the source of the building's low-voltage MAINS installation.		This product complies with the WEEE Directive marking requirements. The affixed label indicates that you must not discard this electrical/electronic product in domestic household waste. Product Category: With reference to the equipment types in the WEEE Directive Annex I, this product is classed as category 9 "Monitoring and Control Instrumentation" product. Do not dispose of this product as unsorted municipal waste.
---------------	--	---	--

**Elements of the 9040**

Indicators, buttons, and jacks are shown in Figure 1.

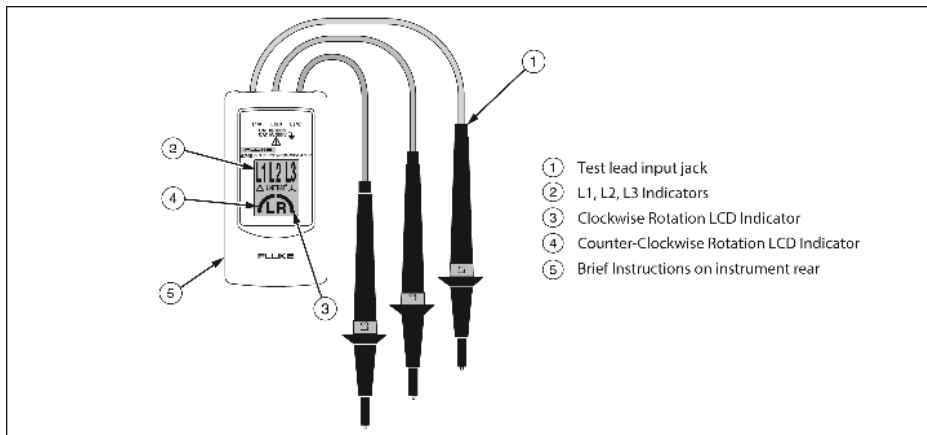

**Figure 1. The 9040 Phase Rotation Indicator**

***Determine the Rotary Field Direction***

To determine the rotary field direction:

1. Connect the test probes to the end of the test leads.
2. Connect the test probes to the three mains phases.
3. Either the clockwise or counter-clockwise rotary indicator illuminates showing the type of rotary field direction present.

** Warning**

**The rotary indicator lights even if the neutral conductor, N, is connected instead of L1, L2, or L3. Refer to the back of the 9040 for more information.**

*Note*

*The 9040 is powered from the installation under test.*

## **Maintaining the 9040**

### **⚠⚠ Warning**

To prevent possible electrical shock, fire, or personal injury, do not operate the Product with covers removed or the case open. Hazardous voltage exposure is possible.

### **⚠ Caution**

To prevent damage to the 9040:

- **Do not attempt to repair or service the 9040 unless qualified to do so.**
- **Make sure that the relevant calibration, performance test, and service information is being used.**
- **Do not use abrasives or solvents. Abrasives or solvents will damage the 9040 case.**

The only maintenance the 9040 requires is inspection and cleaning. Periodically wipe the case with a damp cloth and mild detergent. Clean only with soap and water and remove any residue afterwards.

## **Replacing the Fuse (9040UK only)**

### **⚠⚠ Warning**

**For safe operation and maintenance of the product:**

- **Use only specified replacement fuses. See Specifications section.**
- **Before you replace the fuse, disconnect the accessory (cable or probe) at both ends.**

To replace the fuse:

1. Check the fuse using a simple continuity test.
2. Hold the probe in front of the finger guard and unscrew the tip in a counter-clockwise direction.
3. Remove the defective fuse from the fuse holder.
4. Insert a new fuse in the fuse holder and reassemble the probe.

### **Specifications**

**Maximum voltage between any Terminal and Earth Ground:** 600 V

**Power:** Supplied by circuit under test.

**Fuse:** (9040 UK model only) 0.5 A, 1000 V, 50 kA, 6.3 mm x 32 mm

**Determine Rotary Field Direction:**

Nominal Voltage: 40 V to 690 V ac ( $U_{me}$ )

Frequency Range ( $f_n$ ): 15 Hz to 400 Hz

Current Pickup: 1 mA

Nominal Test Current (in each phase): 1 mA

**Temperature:**

Operating: -10 °C to +40 °C

Storage: -40 °C to +60 °C

**Operating Relative Humidity:**

15 % to 80 %

**Altitude:**

Operating: ≤2000 m

Storage: ≤2000 m

**Size:** 12.4 cm x 6.1 cm x 2.7 cm

**Weight:** 200 g

**Safety:**

IEC 61010-1: Pollution Degree 2

IEC 61010-2-030: Measurement CAT III  
600 V/CAT IV 300 V

IEC 60925: IP40 (non-operating)

IEC 61557-7: Phase sequence

**Electromagnetic Compatibility:**

International: IEC 61326-1: Industrial Electromagnetic Environment

CISPR 11: Group 1, Class A

*Group 1: Equipment has intentionally generated and/or uses conductively-coupled radio frequency energy that is necessary for the internal function of the equipment itself.*

*Class A: Equipment is suitable for use in all establishments other than domestic and those directly connected to a low-voltage power supply network that supplies buildings used for domestic purposes. There may be potential difficulties in ensuring electromagnetic compatibility in other environments due to conducted and radiated disturbances.*

*Caution: This equipment is not intended for use in residential environments and may not provide adequate protection to radio reception in such environments.*

*Emissions that exceed the levels required by CISPR 11 can occur when the equipment is connected to a test object.*

*The equipment may not meet the immunity requirements of this standard when test leads and/or test probes are connected.*

Korea (KCC): Class A Equipment (Industrial Broadcasting & Communication Equipment)

*Class A: Equipment meets requirements for industrial electromagnetic wave equipment and the seller or user should take notice of it. This equipment is intended for use in business environments and not to be used in homes.*

USA (FCC): 47 CFR 15 subpart B. This product is considered an exempt device per clause 15.103.