

# Megger<sup>R</sup>



## System R 30

### Modular Test Van

## USER GUIDE

Issue: F (07/2024) - EN  
Article number: 128311867





## Consultation with Megger

The present system manual has been designed as an operating guide and for reference. It is meant to answer your questions and solve your problems in as fast and easy a way as possible. Please start with referring to this manual should any trouble occur.

In doing so, make use of the table of contents and read the relevant paragraph with great attention. Furthermore, check all terminals and connections of the instruments involved.

Should any question remain unanswered or should you need the help of an authorized service station, please contact:

Megger Limited  
 Archcliffe Road  
 Kent CT17 9EN  
 T: +44 1304 502100  
 F: +44 1304 207342  
 E: [uksales@megger.com](mailto:uksales@megger.com)

Megger Germany GmbH (Baunach)  
 Dr.-Herbert-Iann-Str. 6  
 D - 96148 Baunach  
 T: +49 9544 68 – 0  
 F: +49 9544 22 73  
 E: [team.dach@megger.com](mailto:team.dach@megger.com)

Megger Germany GmbH (Radeburg)  
 Röderaue 41  
 D - 01471 Radeburg / Dresden  
 T: +49 35208 84 – 0  
 F: +49 35208 84 249  
 E: [team.dach@megger.com](mailto:team.dach@megger.com)

Megger USA  
 Valley Forge Corporate Centre  
 2621 Van Buren Avenue  
 Norristown, PA 19403 USA  
 T: +1 610 676 8500  
 F: +1 610 676 8610

© Megger

All rights reserved. No part of this handbook may be copied by photographic or other means unless Megger have before-hand declared their consent in writing. The information in this document is subject to change without notice and should not be construed as a commitment by Megger. Megger cannot be made liable for technical or printing errors or shortcomings of this handbook. Megger also disclaims all responsibility for damage resulting directly or indirectly from the delivery, supply, or use of this matter.

**Terms of Warranty**

Megger accept responsibility for a claim under warranty brought forward by a customer for a product sold by Megger under the terms stated below.

Megger warrant that at the time of delivery Megger products are free from manufacturing or material defects which might considerably reduce their value or usability. This warranty does not apply to faults in the software supplied. During the period of warranty, Megger agree to repair faulty parts or replace them with new parts or parts as new (with the same usability and life as new parts) according to their choice.

This warranty does not cover wear parts, lamps, fuses, batteries and accumulators.

Megger reject all further claims under warranty, particularly those from consequential damage. Each component and product replaced in accordance with this warranty becomes the property of Megger.

All warranty claims versus Megger are hereby limited to a period of 12 months from the date of delivery. Each component supplied by Megger within the context of warranty will also be covered by this warranty for the remaining period of time but for 90 days at least.

Each measure to remedy a claim under warranty shall exclusively be carried out by Megger or an authorized service station.

This warranty does not apply to any fault or damage caused by exposing a product to conditions not in accordance with this specification, by storing, transporting, or using it improperly, or having it serviced or installed by a workshop not authorized by Megger. All responsibility is disclaimed for damage due to wear, will of God, or connection to foreign components.

For damage resulting from a violation of their duty to repair or re-supply items, Megger can be made liable only in case of severe negligence or intention. Any liability for slight negligence is disclaimed.

Since some states do not allow the exclusion or limitation of an implied warranty or of consequential damage, the limitations of liability described above perhaps may not apply to you.

**Contents**

**Consultation with Megger** .....3

**Terms of Warranty** .....4

**Contents** .....5

**1 Safety Instructions** .....8

1.1 General Notes .....8

1.2 General Safety Instructions and Warnings.....9

**2 Technical description** .....11

2.1 Description .....11

2.2 Technical data .....13

2.3 Displays and controls .....16

**3 Putting the test van into operation** .....20

3.1 Setting up the test van and cordoning up the area .....20

3.2 Electrical connection .....21

3.2.1 Connection equipment .....22

3.2.2 Connection of the earth cable .....23

3.2.3 Connection of the FU cable (auxiliary earth).....24

3.2.4 Connection to the test object.....25

3.2.4.1 Using the HV connection cable .....25

3.2.4.2 Using the Teleflex LV cable (optional) .....27

3.2.4.3 Using the MFM/HVB connection cable (optional) .....28

3.2.5 Connecting the power cable.....29

3.2.6 Connection of the external safety device (optional) .....31

3.3 Use of USB accessories.....33

3.4 Setting up switch-on standby .....34

3.5 Switching on the test van .....35

**4 Operating the test van in general** .....36

4.1 Switching high voltage on and off .....36

**5 Operating the Teleflex VX**.....37

5.1 Screen layout .....37

5.2 Basics of control .....39

5.3 Quick selection of operating modes -  .....42















5.4 Phase selection -  .....43

5.5 History database -  .....45

5.6 System settings -  .....49

5.6.1 Data menu -  .....51

5.6.2 Basic settings -  .....52

5.6.3	Administration menu -  (administration password required).....	54
5.6.3.1	Backing up and updating data -     .....	55
5.6.3.2	User administration -  .....	56
5.6.3.3	Connection Lead Calibration -  .....	57
<b>6</b>	<b>Conducting measurements .....</b>	<b>58</b>
6.1	Good to know .....	58
6.1.1	Propagation velocity .....	58
6.1.2	Pulse width .....	59
6.1.3	Typical TDR reflectograms .....	60
6.2	Standard functions .....	61
6.3	Systematics of cable fault location .....	64
6.4	Insulation measurement .....	65
6.4.1	Insulation testing with an external insulation tester .....	65
6.4.2	Insulation testing with internal ISO module .....	66
6.4.3	Measurement of insulation resistance and test object capacitance .....	66
6.4.4	Time-dependent measurement of resistance -  .....	69
6.5	Cable testing -  .....	71
6.6	Pulse reflection measurement (TDR) -  .....	75
6.7	Pre-location of high-resistance cable faults -  .....	78
6.7.1	Arc reflection measurement (ARM) -  .....	78
6.7.1.1	ARM measurement up to 12 kV (with Surge Unit 3/6/12 kV) .....	80
6.7.1.2	ARM measurement up to 50 kV (double surge unit) .....	82
6.7.2	Voltage decoupling (DECAY) -  .....	84
6.7.3	Current decoupling (ICE) -  .....	86
6.7.3.1	ICE prelocation up to 12 kV (with Surge Unit 3/6/12 kV) .....	86
6.7.3.2	ICE prelocation up to 50 kV or 80 / 100 kV (optional) .....	88
6.7.4	Three-phase current decoupling (optional) -  .....	91
6.7.5	ARM burning with the 15 kV burn down unit (optional) -  .....	94
6.8	Burning .....	96
6.8.1	Burning up to 110 kV (with internal voltage source) .....	96
6.8.2	Burning with the 15 kV burn unit (optional) .....	97
6.9	Fault pinpointing .....	98
6.9.1	Surge pinpointing up to 12 kV (with surge unit 3/6/12 kV) .....	98
6.9.2	Surge pinpointing up to 50 kV .....	100
6.9.3	Surge pinpointing up to 80/100 kV (optional) .....	101
6.9.4	Line and fault location with the audio frequency generator .....	102
6.10	Sheath test and sheath fault location with the MFM 10-M / HVB 10-M (optional) .....	105
6.11	Completing the work .....	106
<b>7</b>	<b>Exporting and processing measurement data .....</b>	<b>107</b>
<b>8</b>	<b>Troubleshooting .....</b>	<b>108</b>

---

<b>9</b>	<b>Care and Maintenance .....</b>	<b>111</b>
9.1	Required maintenance by a service workshop .....	111
9.2	Maintenance work you can carry out yourself.....	111



## 1 Safety Instructions

### 1.1 General Notes

**Safety precautions** This manual contains basic instructions for the commissioning and operation of the device / system. For this reason, it is important to ensure that the manual is always available to the authorized and trained operator. He needs to read the manual thoroughly. The manufacturer is not liable for damage to material or humans due to non-observance of the instructions and safety advices provided by this manual.

Locally applying regulations must be observed!

**Labelling of safety instructions** The following signal words and symbols are used in this manual and on the product itself:

Signal word / symbol	Description
<b>DANGER</b>	Indicates a potential hazard which <b>will result</b> in death or serious injury if not avoided.
<b>WARNING</b>	Indicates a potential hazard which <b>may result</b> in death or serious injury if not avoided.
<b>CAUTION</b>	Indicates a potential hazard which may result in moderate or minor injury if not avoided.
<b>NOTICE</b>	Indicates a potential hazard which may result in material damage if not avoided.
	Serves to highlight warnings and safety instructions. As a warning label on the product, it is used to draw attention to potential hazards which have to be avoided by reading the manual.
	Serves to highlight warnings and safety instructions that explicitly indicate the risk of an electric shock.
	Serves to highlight important information and useful tips on the operation of the device/system. Failure to observe may lead to unusable measurement results.

**Working with products from Megger** It is important to observe the generally applicable electrical regulations of the country in which the device will be installed and operated, as well as the current national accident prevention regulations and internal company directives (work, operating and safety regulations).

After working on the system, it must be voltage-free and secured against reconnection as well as having been discharged, earthed and short-circuited.

Use genuine accessories to ensure system safety and reliable operation. The use of other parts is not permitted and invalidates the warranty.

**Operating staff** The system may only be installed and operated by an authorized electrician. DIN VDE 0104 (EN 50191), DIN VDE 0105 (EN 50110) and the German accident prevention regulations (UVV) define an electrician as someone whose knowledge, experience and familiarity with the applicable regulations enables him to recognize potential hazards.

Anyone else must be kept away!

**Repair and maintenance** Repair and maintenance work must be carried out by Megger or authorized service partners using original spare parts only. Megger recommends having the system tested and maintained at a Megger service centre once a year.

Megger also offers its customers on-site service. Please contact your service centre if needed.

**Electromagnetic radiation** This device is designed for industrial use. When used at home it could cause interference to other equipment, such as the radio or television.

The interference level from the line complies with the limit curve B (living area), the radiation level complies with the limit curve A (industrial area) according to EN 55011. Given that living areas are sufficiently far away from the planned area of operation (industrial area), equipment in living areas will not be impaired.

## 1.2 General Safety Instructions and Warnings

**Intended application** The operating safety is only guaranteed if the delivered system is used as intended (see page 11). Incorrect use may result in danger to the operator, to the system and the connected equipment.

The thresholds listed in the technical data may not be exceeded under any circumstances.

**Operation in traffic environment** To ensure safety for operators and traffic, the country-specific regulations must be observed.

**Five safety rules**

The five safety rules must always be followed when working with HV (High Voltage):

1. De-energize
2. Protect against re-energizing
3. Confirm absence of voltage
4. Earth and short-circuit
5. Cover up or bar-off neighbouring energized parts





**Using cardiac pacemaker / defibrillator**

Physical processes during operation of high voltage may endanger persons wearing a cardiac pacemaker or defibrillator when near these high voltage facilities.

	<p><b>Firefighting in electrical installations</b></p> <ul style="list-style-type: none"> <li>• According to regulations, carbon dioxide (CO<sub>2</sub>) <b>is required to be used</b> as extinguishing agent for fighting fire in electrical installations.</li> <li>• Carbon dioxide is electrically nonconductive and does not leave residues. It is safe to be used in energized facilities as long as the minimum distances are maintained. A CO<sub>2</sub> fire extinguisher must be always available within electrical installations.</li> <li>• If, contrary to the regulations, any other extinguishing agent is used for firefighting, this may lead to damage at the electrical installation. Megger disclaims any liability for consequential damage. Furthermore, when using a powder extinguisher near high-voltage installations, there is a danger that the operator of the fire extinguisher will get an electrical shock from a voltage arc-over (due to the powder dust created).</li> <li>• It is essential to observe the safety instruction on the extinguishing agent.</li> <li>• Applicable is DIN VDE 0132.</li> </ul>
---	---

	<p>Objects should not be placed on or lent against the heater, nor pushed between the heater and wall.</p> <p>Do not cover the air exit or leave any combustible material in close vicinity to the heater.</p>
--	--

	<p><b>WARNING</b></p> <p><b>Dangers when working with high voltage</b></p> <p>Working on high voltage systems and equipment – especially in non-stationary operation – requires particular care and safety-conscious action on the part of test personnel. VDE regulations 0104 on setting up and operating electrical test systems, as well as EN 50191 and national standards and regulations must be strictly adhered to.</p> <ul style="list-style-type: none"> <li>• The System R 30 generates a dangerous voltage of up to 110 kV during measurement operation. This is supplied to the test object via a high-voltage cable.</li> <li>• The test system may not be operated without supervision.</li> <li>• Never fail to use safety equipment or put it out of operation.</li> <li>• Operation requires minimum two people whereas the second person must be able to activate the emergency switch in case of danger.</li> <li>• To prevent dangerous charge accumulation, earth all metal parts in the vicinity of the high voltage equipment.</li> </ul>
---	--

	<p><b>WARNING</b></p> <p><b>Peripheral devices</b></p> <p>Please follow the safety instructions of the peripheral devices (e.g. heater) installed in the system environment. For all peripheral devices provided by Megger, the instructions manual is included in the scope of delivery. Megger is not liable for damage to material or humans due to misuse of these devices.</p>
---	---

## 2 Technical description

### 2.1 Description

*Concept* The powerful System R 30 three-phase test van combines the proven individual devices of the Megger product range in almost any configuration combination and is suitable for fast, simple and cable-gentle fault location on power cables. Optionally equipped with powerful VLF test equipment and advanced diagnosis system, the system can also be used for standard-compliant cable tests and partial discharge diagnosis.

The central component of the system is the proven Teleflex VX, via which both the operating mode and the phases are selected. Depending on the selected operating mode, the required individual devices are provided with mains voltage and the HV path is switched. All individual devices of the test van are integrated in a control and safety concept that has been adapted to the requirements of cable testing and fault location.

*Features* The System R 30 test van offers the following features:

- Modular and thus fail-safe system
- The highest safety standards
- Mains and generator operation
- Depending on the configuration, access to all state-of-the-art cable testing systems and methods
- DC test voltage, up to 110 kV (optional: 150 kV)
- Surging for prelocation and pinpointing, up to 50 kV (100 kV optional)

*Equipment variants* Each System R 30 test van has certain basic equipment that essentially comprises the following components:

- Connectors (HV connection cable, earth cable)
- motor switch for operating mode switching 110 kV
- Combined discharge and earthing switch, 110 kV
- Control panel
- DC high voltage source, 110 kV
- Teleflex VX reflectometer (central operating unit for selecting the operating modes and for recording, displaying and storing measurement data)
- Surge unit 3/6/12 kV
- 25/50 kV surge circuit
- ARM filter
- ARM double surge unit (for ARM prelocation up to 50 kV)
- Single-phase current decoupling (optional: three-phase current decoupling)
- Test van accessories (which include, among other things, spare fuses and the SF<sub>6</sub> filling unit H902)

In addition to this basic equipment, the test van can include a selection of the following optional components:

- VLF CR-54 kV test attachment
- VLF CR-70 kV test attachment
- Partial discharge measuring system PDS 60(-HP) / PDS 62-SIN
- 15 kV burn unit
- ISO module for insulation testing
- Sheath test and fault location system (MFM 10-M / HVB 10-M), including its own cable reel
- Audio frequency generator (FLG 200)
- Surging with up to 80 kV or 100 kV (incl. current decoupling)
- Three-phase current decoupling up to 50 kV
- External safety device, including cable reel
- Teleflex LV cable reel

## 2.2 Technical data

The test van itself is defined by the following parameters:

Parameter	Value
Mains voltage	230 V (+6%, -10%), 50 / 60 Hz Connection via isolating transformer (5 kVA)
Power supply	5 kVA (continuous load)
HV switch	Gas-insulated, suitable for voltages up to 110 kV
Discharge capacity	10 $\mu$ F at 110 kV
HV connectors	3 x 1-phase or 1 x 3-phase HV connection cable, 50 m
LV connectors	1 x 3-phase LV connection cable, 50 m (optional)
Power supply connectors / safety	Power cable, 50 m (incl. matching isolating transformer) Earth cable, 50 m Auxiliary earth connection cable (FU), 10 m External safety device connection cable, 50 m (optional)
Interfaces	External sockets (for external Insulation resistance tester, max. 1000 V)
<b>Time Domain Reflectometer (Teleflex VX)</b>	
• Display	15" touch screen, 1980 x 1020
• Operating modes	Symmetric/asymmetric reflection measurement, differential and comparative measurement, IFL (for intermittent faults)
• Amplification	Default : 0 ... 100%; ProRange: >22 dB
• Measuring range (at $v/2 = 80$ m/ $\mu$ s)	20 m ... 1,280 km (250 ns ... 16 ms)
• Resolution	0,1 m
• $v/2$ range	10 ... 149.9 m/ $\mu$ s
• NVP range	0.067 ... 1
• Accuracy	0.1% of measurement range
• Data rate	533 MHz
• Measuring dynamic	>80 dB
• Pulse width	20 ns ... 10 $\mu$ s
• Pulse amplitude	50, 150 V
<b>Testing with DC voltage</b>	
• Voltage range	0 to 110 kV
• Nominal current	5 mA
• Short-circuit current	290 mA

Parameter	Value
<b>Surge energy</b> <ul style="list-style-type: none"> <li>Surge unit 3/6/12 kV</li> <li>25/50 kV surge circuit</li> <li>80 kV surging (optional)</li> <li>100 kV surging (optional)</li> </ul>	See technical data of Surge Unit 3/6/12 kV 2500 J 1600 J or 3200 J 2000 J
<b>ISO module (optional)</b> <ul style="list-style-type: none"> <li>Test voltage</li> <li>Resistance measuring range</li> <li>Capacitance measuring range (only with 500 V or 1000 V)</li> <li>Trend measurement (only with 500 V or 1000 V)</li> </ul>	<6 V, 500 V, 1000 V 1 Ω to 2 kΩ (with <6 V) 1 kΩ to 2 GΩ (with 500 V) 1 kΩ to 2 GΩ (with 1000 V) 0 to 20 μF (resolution 0.1 μF) Up to 15 minutes
<b>VLF CR-54 kV test attachment (optional)</b> <ul style="list-style-type: none"> <li>Voltage wave shape</li> <li>Voltage range</li> <li>Maximum load capacitance</li> </ul>	Cosine square wave (0.1 Hz) 0 to 54 kV 5 μF@54 kV, 8 μF@36 k, 21 μF@18 kV
<b>VLF CR-70 kV test attachment (optional)</b> <ul style="list-style-type: none"> <li>Voltage wave shape</li> <li>Voltage range</li> <li>Maximum load capacitance</li> </ul>	Cosine square wave (0.1 Hz) 0 to 70 kV 5 μF@70 kV, 7.7 μF@54 kV, 13.9 μF@36 kV, 34.7 μF@18 kV
<b>Audio frequency generator (FLG) (optional)</b> <ul style="list-style-type: none"> <li>Frequencies</li> <li>Output power</li> </ul>	0.491 kHz, 0.982 kHz, 8.440 kHz (customer-specific frequencies are possible) 200 W (models 50 W or 10 W are available as external devices)
<b>15 kV burn unit (optional)</b>	See the enclosed operating manual
<b>MFM 10-M sheath fault locator (optional)</b>	See the enclosed operating manual
<b>HVB 10-M high voltage measuring bridge (optional)</b>	See the enclosed operating manual
Operating temperature	-20 °C to +55 °C
Storage temperature	-25 °C to +60 °C
Operating humidity	93% at 30 °C (non-condensing)
Weight of the HV range	Approx. 1050 kg (depending on the equipment)

*Technical data of the Surge Unit 3/6/12 kV* Depending on its configuration, the Surge Unit 3/6/12 kV is specified by the following parameters:

Parameter	Value
<b>Surge voltage levels</b>	0 ... 3 kV, 0 ... 6 kV, 0 ... 12 kV
<b>Surge rate</b>	
• adjustable	ca. 0.8 ... 8 s
• electronically controlled	≥4.5 s (3 kV), ≥2.5 s (6 kV), ≥4.0 s (12 kV)
<b>Surge energy</b> (see also the diagram below)	1000 J in standard version or 2000 J with option „double surge energy“
<b>Kurzschlussstrom</b>	155 mA
<b>Power consumption</b>	max. 2,000 VA

Depending on the configuration and the selected voltage range the Surge Unit 3/6/12 kV provides the following surge energy:

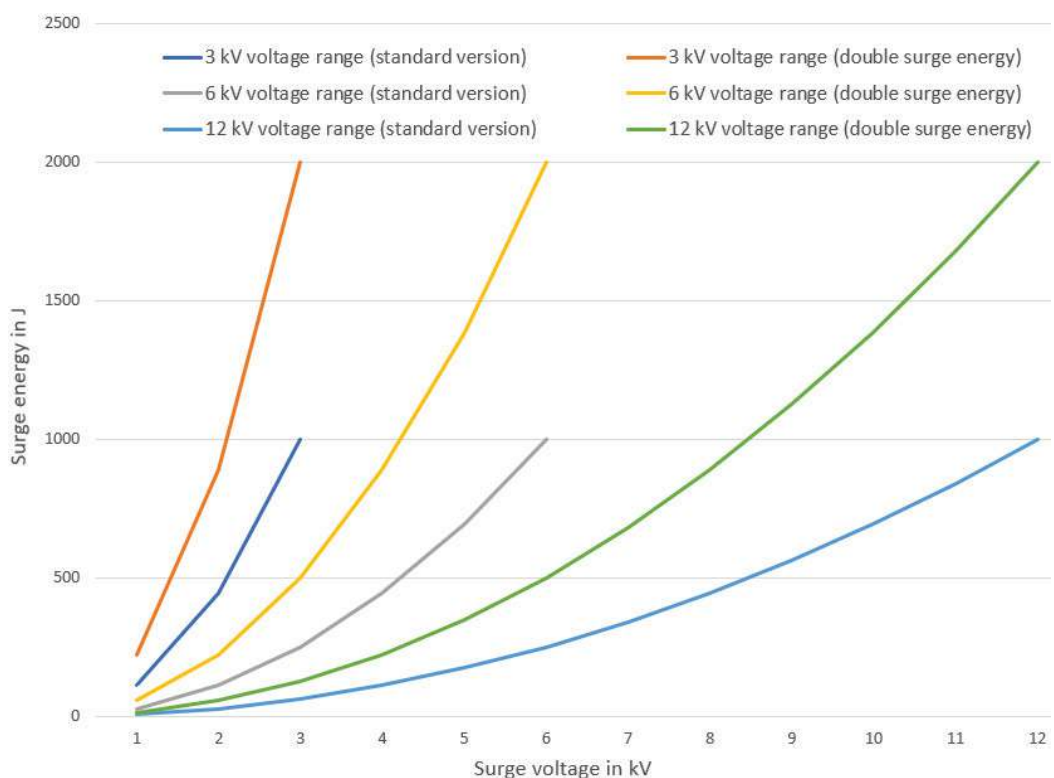

*Technical data of other measurement equipment / peripherals*



The technical data of additional measurement equipment (for example, digiPhone+, PDS 60, Tan Delta test attachment) and peripherals (for example, generator system) contained in the test van can be found in the respective operating instructions.

## 2.3 Displays and controls

*Control console* All the components that are required to control, test and monitor the measurements are installed on the control console. The following figure shows an example of the equipment of the control console at a typical configuration level:

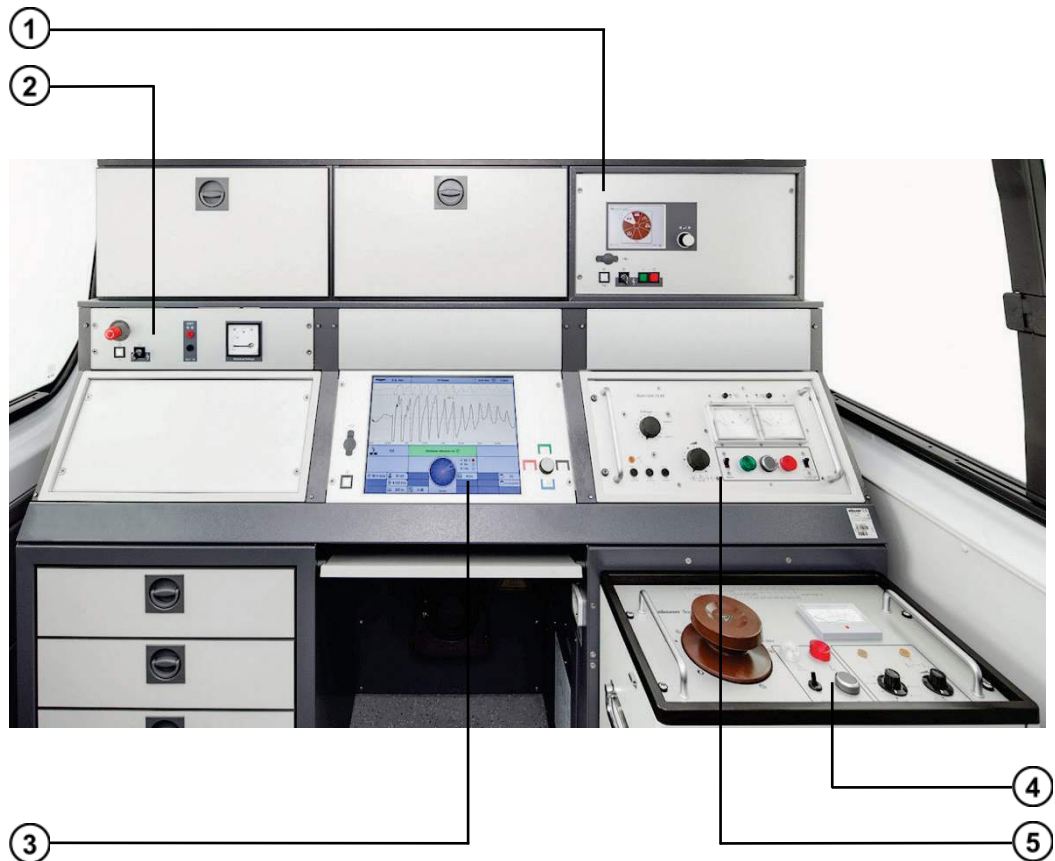

Component	Description
①	MFM 10-M / HVB 10-M (optional)
②	Control panel
③	Teleflex VX
④	Surge unit 3/6/12 kV
⑤	15 kV burn unit (optional)

*Teleflex Vx* The Teleflex VX is the central operating unit of the test van and has the following operating elements:

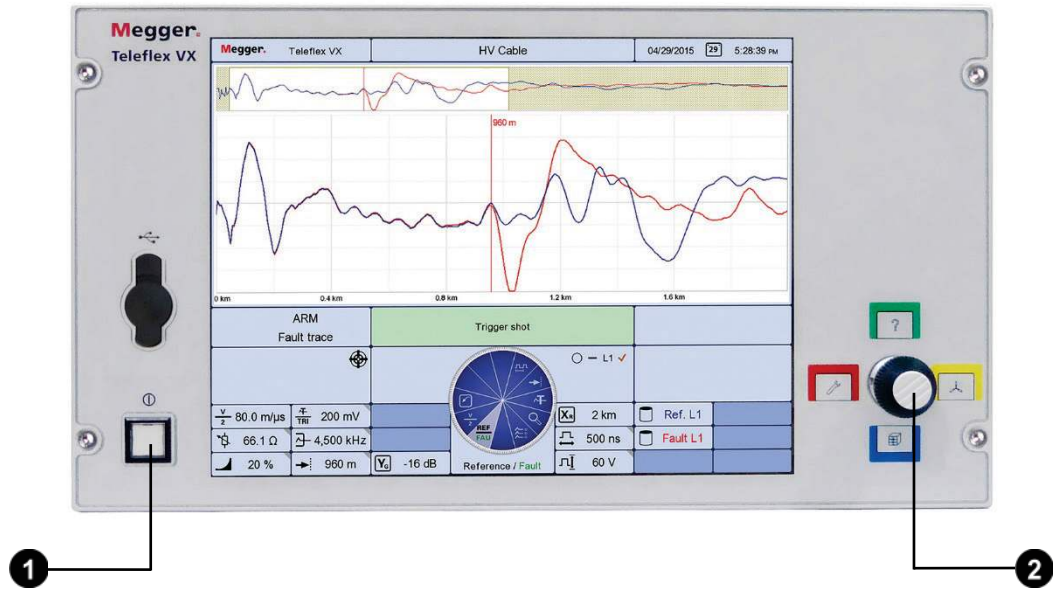

Element	Beschreibung
1	On/off switch
2	Rotary encoder

*Control panel* The control panel has the following controls and displays:

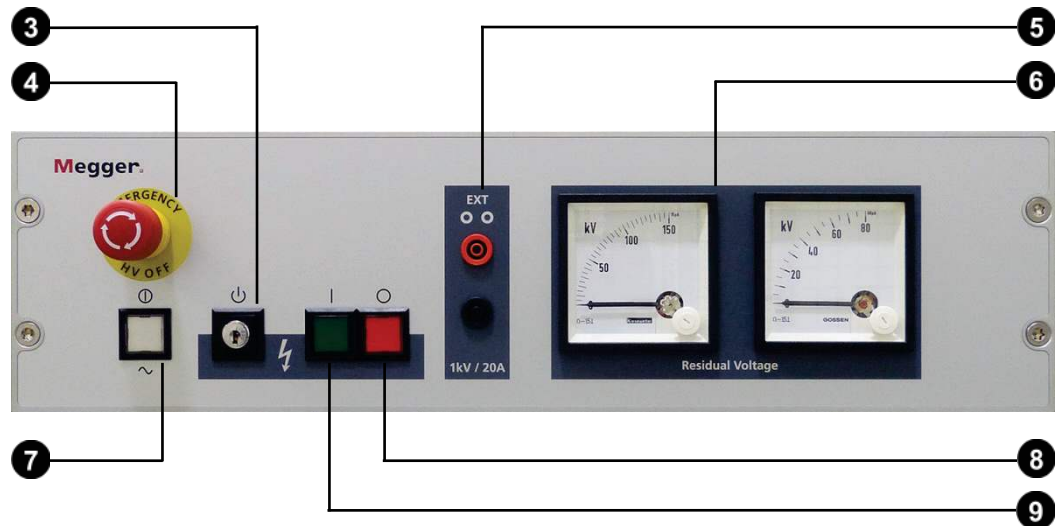

Element	Description
<b>3</b>	"HV Interlock" key switch (see page 36)
<b>4</b>	EMERGENCY OFF switch Pressing the EMERGENCY STOP button will shut off the high voltage immediately and discharge the test object before earthing the HV output. The plug sockets in the control room will still be live.
<b>5</b>	External sockets
<b>6</b>	Residual voltage indicator (optional) The residual voltage indicator signals the voltage that is currently present at the HV output of the system. Systems which are equipped with a test and diagnosis module (TDM) can also have a second residual voltage indicator (always located on right of actual indicator). The voltage that is currently present at the single-phase diagnosis output is signaled on this.
<b>7</b>	Main switch
<b>8</b>	„HV Off“ button
<b>9</b>	„HV On“ button

Surge unit 3/6/12 kV The surge unit 3/6/12 kV has the following controls and displays:

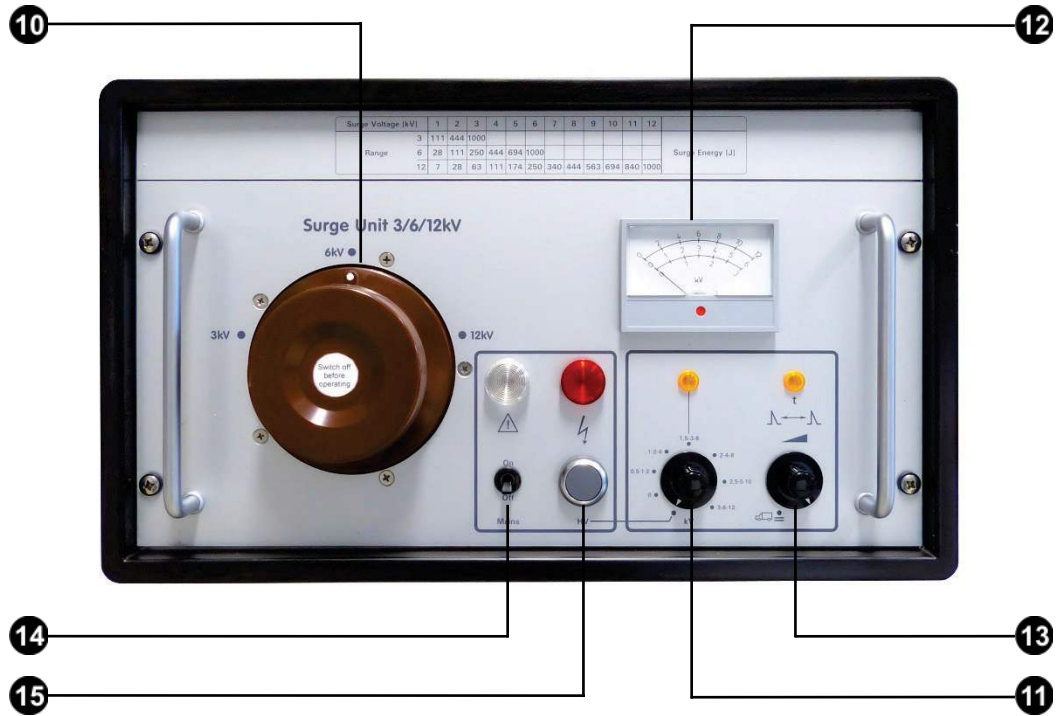

Element	Description
10	Range selector
11	Rotary knob to adjust the voltage
12	kV meter to display the actual charging voltage of the internal surge capacitors
13	Rotary knob to adjust the surge rate
14	On/off switch
15	„HV On“ button

### 3 Putting the test van into operation

#### 3.1 Setting up the test van and cordoning up the area

The guidelines for implementation of occupational safety when operating a test system / test van often differ between one network operator and another and it is not uncommon for national regulations (like, i.e. the German BGI 5191) to be used as well.

Inform yourself of the guidelines applicable in the area of operation beforehand, and comply with the specified rules for work organization and for implementing the test system / test van.

	<p><b>WARNING</b> <b>Risk of electric shock</b></p> <ul style="list-style-type: none"> <li>• The test van must never be placed directly over the route of the cable to be tested!</li> <li>• To ensure that the integrated gravity switches function correctly, the test van must never be operated on inclines that exceed 10%.</li> <li>• The test van must not show any visible damage, e.g. accident damage, as long as this has not yet been classified as harmless by a Megger service center!</li> <li>• In the event of large differences in temperature between the storage and installation locations (cold to warm) condensation may form on components carrying high voltage (condensation effect). To avoid any risk of damage to people and devices caused by voltage flashovers, the system must not be operated when in this condition. It should rather be left in the new environment to acclimatise for approximately one hour before putting it into operation.</li> </ul>
---	--

The following steps must be taken to adequately secure the area and the test van:

Step	Action
1	Place the test van on level ground and close to the access to the test object, considering its load and external dimensions. Check that the test van is in a stable position.
2	Secure the test van against rolling away by applying the handbrake and positioning chocks against the wheels if necessary.
3	To keep people away from the test van and its connection cables, secure the immediate vicinity of the test van in accordance with local regulations using barriers, warning signs and cable bridges.

### 3.2 Electrical connection

The following figure shows the simplified connection diagram:

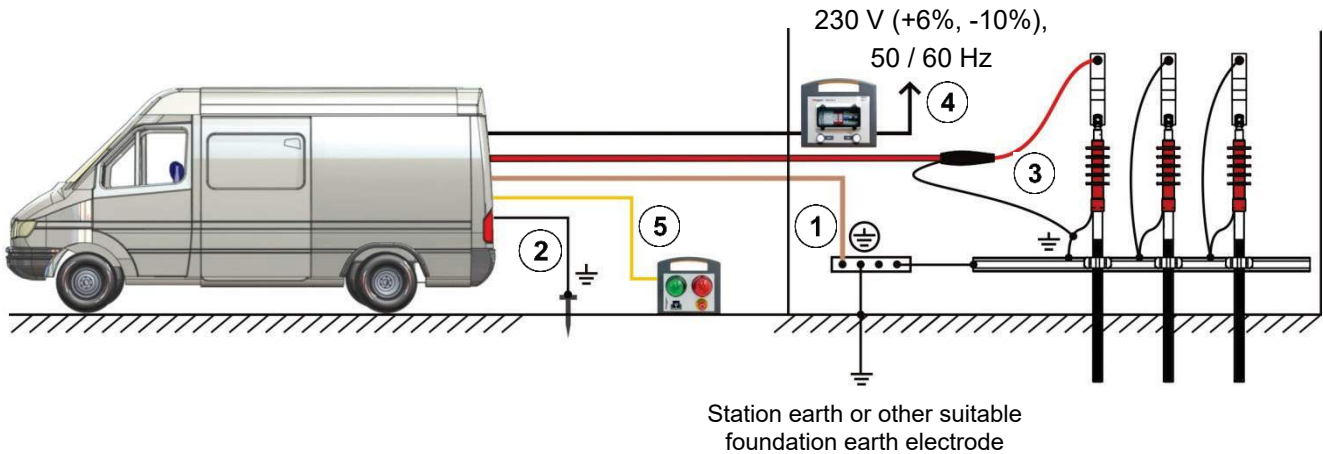

	<p><b>WARNING</b> <b>Risk of electric shock</b></p> <p>The electrical connection must be carried out in the sequence shown in the image. The ground cable must be connected first and the mains connection is made last!</p> <p>For disconnection, follow the sequence in reverse order.</p>
--	--

Follow the specified connection sequence:

- ① Connection of the earth cable (see page 23)
- ② Connection of the FU cable (auxiliary earth) (see page 24)
- ③ Connection to the test object (see page 25)
- ④ Connection to the mains (see page 29)
- ⑤ Connection of the external safety device (optional) (see page 31)

### 3.2.1 Connection equipment

**i** Type and arrangement of the connection equipment may differ depending on the type of vehicle and the configuration.

Usually, the equipment includes the cable reels shown in the following figure:

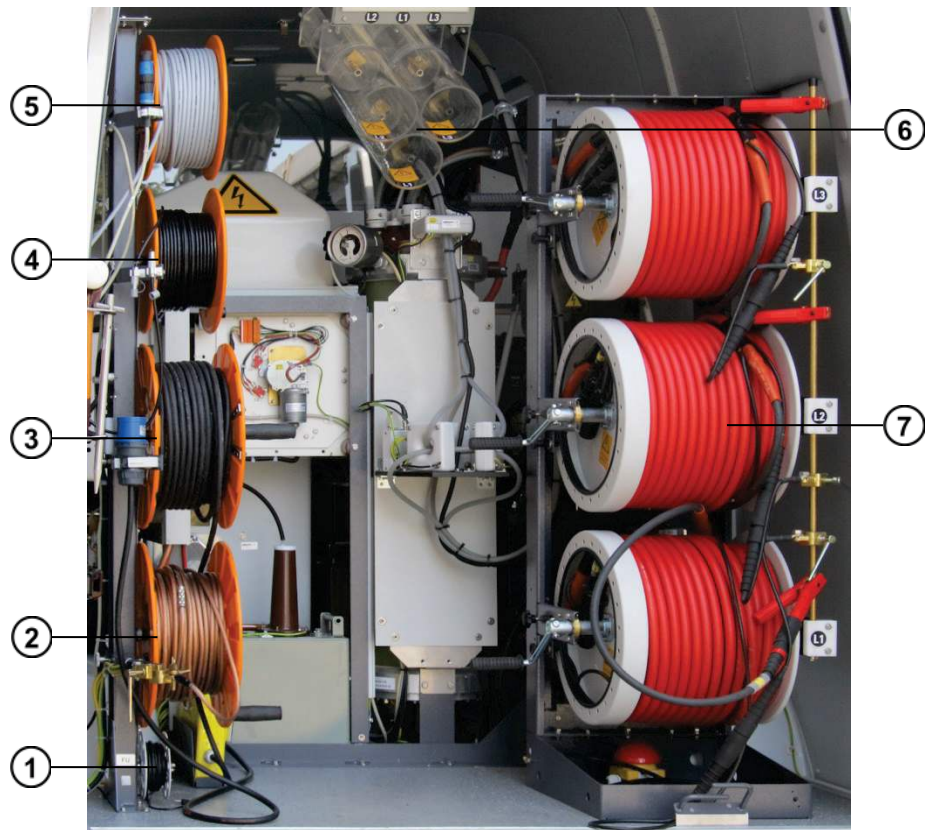

Part	Description
①	Cable reel of FU cable
②	Cable reel of earth cable
③	Power cable reel
④	Teleflex LV cable reel (optional) for three-phase reflection measurements with low voltage
⑤	Cable reel of ext. safety device (optional)
⑥	HV connection panel
⑦	High voltage cable reel

### 3.2.2 Connection of the earth cable

	<p><b>WARNING</b> <b>Risk of electric shock</b></p> <ul style="list-style-type: none"> <li>• The test van should never be operated without the earth cable being connected. This applies in respect of mains operation as well as generator operation. The earth cable establishes the connection between the system and the protective earth and ensures that the entire system is touch-proof.</li> <li>• The test van should be operated only on earthing systems or single earth electrodes with transition resistances <math>&lt;2 \Omega</math>.</li> <li>• The protective earth (earth cable) and system earth (screen of the HV cable) must be connected so that no unacceptable voltage difference may arise between the protective earth (PE) and neutral conductor (N).</li> <li>• For TT networks, there is no connection between the neutral conductor (N) and protective earth (PE) in the station. This connection must be created for the measurement with a suitable cable.</li> </ul>
--	---

Proceed as follows to connect the earth cable:

Step	Action
1	Release the brake of the earth cable reel.
2	Unwind the cable and connect it to the station earth or other suitable foundation earth.
3	Clamp one of the contact sleeves attached to the cable at intervals of 5 m under the connecting clamp next to the cable reel.
4	Secure the cable reel brake again.

### 3.2.3 Connection of the FU cable (auxiliary earth)

Proceed as follows to connect the FU cable (auxiliary earth) to monitor the voltage-time integral and fault voltage:

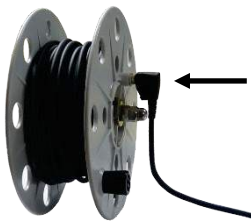
Step	Action
1	Unwind the FU cable.
2	Place the earth spike into the ground in the immediate vicinity of the test van and attach the FU cable to it. <div style="text-align: center; margin-top: 10px;">  </div>
3	Connect the other end of the cable to the connector on the FU cable reel. <div style="text-align: center; margin-top: 10px;">  </div>



If after switching the test van on high voltage operation is blocked due to poor earthing conditions despite the connected auxiliary earth, the measures may correct the situation:

- Try inserting the earthing rod in other locations which may be more suitable. In heavily built-up areas, the gaps between the concrete slabs can be used, for example.
- Use water to moisten the location where the earthing rod has been inserted.
- Attach the auxiliary earth to a foundation earth (e.g. a lightning protection system). Do not use the same foundation earth to which you have already connected the main earthing cable.

### 3.2.4 Connection to the test object

	<p><b>WARNING</b>  <b>Risk of electric shock</b></p> <ul style="list-style-type: none"> <li>• Before connecting to the test object or before adjusting the wiring in the HV room of the test van, the five safety rules (see page 9) must be applied.</li> <li>• Those phases of the cable under test which are not being tested must be short-circuited and earthed.</li> <li>• Install protective equipment (such as railings, chains or bars) to block access to the hazard zone and prevent the risk of touching live parts.</li> <li>• Because the voltage applied to the device under test can exhibit values that represent a shock hazard, all cable ends must be shielded in accordance with VDE 0104 to prevent contact. Make sure that all cable branches are considered.</li> </ul>
--	---

#### 3.2.4.1 Using the HV connection cable

*Application* For almost all operating modes (exceptions are described in the next sections), the test van is connected with the test object via standard HV connection cable.

*Procedure* Perform the following steps to establish a connection between the HV output and the test object:

Step	Action
1	Make sure that used cable reel is not connected to one of the HV outputs of the system and hence is freely rotatable.
2	Release the brake of the HV cable reel.
3	Unwind the HV connection cable.
4	Connect the screen of the HV connection cable to the earthed screen of the test object (operational earth).
5	Use a suitable terminal to connect the inner conductor of the HV cable to the test object phase to be tested.
6	If required, also connect the remaining two connection cables with the test object. Connection cables which are not required for the current measurement task, are to be short-circuited at the metal bar next to the cable reel.
7	On the system side, connect these cable reels which are connected to the test object to the appropriate HV output of the HV connection panel. (see notes on the next pages).
8	Secure the brake of the HV cable reel again.

*System-side connection in vehicles with standard version* In vehicles without special options, the electrical connection between the HV output and the cable reels must be made as follows:

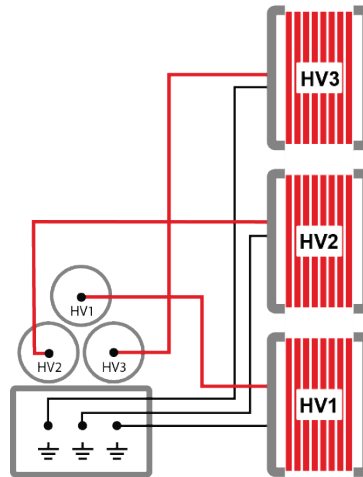

*Special features with vehicles with the 80/100 kV surging option* The connection of the cable reels to the patch panel in the HV area of the test van must be adjusted to correspond to the desired operating mode when switching between normal operation and 80/100 kV surging operation. During the 80/100 kV surging operation, the connection to the test object must **be via cable reel HV3**.

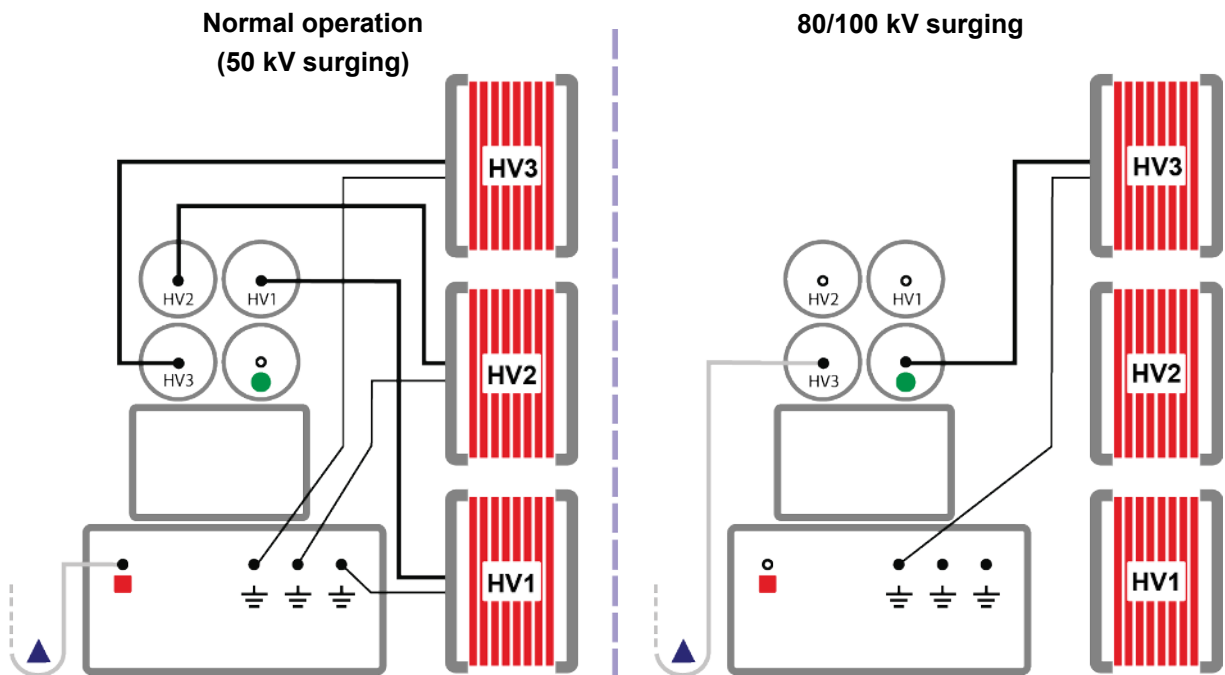



- “80/100kV Surging” HV output
- ▲ Connecting cable from separate 100 kV surge switch
- “80/100kV Surging” earthed parking position

### 3.2.4.2 Using the Teleflex LV cable (optional)

**Application** The Teleflex LV cable can be used exclusively for specially designated LV pulse reflection methods of the Teleflex VX. In all other operating modes, the test object must be connected using the HV connection cable.

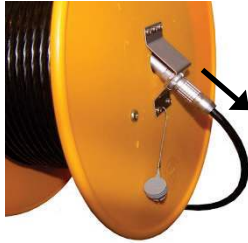
**Procedure** Perform the following steps to connect the LV cable to the test object:

Step	Action
1	<p>If the connection cable coming from the reflectometer is connected to the socket of the cable reel body, this connection must be disconnected before the cable can be unwound.</p> 
2	Unwind the LV cable.
3	Connect the unwound LV cable with the four-core adapter cable pre-assembled for the connection to the test object.
4	<p>Use appropriate connection accessories to connect the individual phases of the LV cable with the phases of the test object and connect the operational earth (red terminal) to the earthed screen of the test object.</p> <hr/> <p><b>i</b> When connecting, make sure that the four wires are run as uniformly as possible to each other (ideally twisted) and are not separated from each other until just before the actual connection point. This ensures that all three phases have similar impedance values.</p> <p>Labeling of the phases must be considered when making the connection in order for it to be possible to properly assign the measurement results to the respective phases.</p> <hr/>
5	<p>Reconnect the connection cable coming from the reflectometer with the socket on the cable reel.</p> 

### 3.2.4.3 Using the MFM/HVB connection cable (optional)

*Application* The special MFM/HVB connection cable is connected directly to the sheath fault location system MFM 10-M or the high voltage bridge HVB 10-M respectively and is used exclusively for the operating modes of these devices.

*Procedure*



---

---

For detailed instructions for the connection to the test object, please read the operating manual of the MFM 10-M or HVB 10-M respectively.

---



---

### 3.2.5 Connecting the power cable

	<p><b>WARNING</b>  <b>Risk of electric shock</b></p> <p>If the object under test and the mains power supply are connected to different earthing systems which are not linked to each other, potential equalisation must be established during operation of the test van (using a connection cable with a cross section of at least 16 mm<sup>2</sup> Cu). Good earthing conditions are extremely important!</p>
--	---

*Procedure* Proceed as follows to connect the test van to the mains power supply:

Step	Action		
1	Release the brake of the mains cable reel.		
2	<p>Release the anti-roll latch on the outside of the cable drum housing by pulling the metal bar outward.</p> <p>To lock the anti-roll latch before winding the drum back up, press on the round screw head.</p> <div style="text-align: center;"> </div>		
3	<p>Unwind the mains supply cable.</p> <table border="1" style="width: 100%; margin-top: 10px;"> <tr> <td style="text-align: center; vertical-align: middle;"> </td> <td> <p><b>CAUTION</b>                      The mains cable drum must always be completely unrolled!</p> </td> </tr> </table>		<p><b>CAUTION</b>                      The mains cable drum must always be completely unrolled!</p>
	<p><b>CAUTION</b>                      The mains cable drum must always be completely unrolled!</p>		

Step	Action
4	<p data-bbox="552 286 1062 318">Connect the cable to a mains power outlet.</p> <div data-bbox="552 365 1449 577" style="border: 1px solid black; padding: 5px;">  <p data-bbox="724 376 852 407"><b>CAUTION</b></p> <p data-bbox="724 416 1442 568">Only approved (VDE/IEC or corresponding national regulations) intermediate connections are to be used for the connection to mains sockets that do not fit the pre-assembled plug or for direct connection to the low-voltage cable!</p> </div> <p data-bbox="552 636 1442 757"><b>Result:</b> The two signal lamps <b>IN</b> and <b>OUT</b> on the mains connection system NAS 60-3 should now light up, indicating that the input voltage is within the permissible range. If this is not the case, check the mains supply and the fuses in the NAS 60-3 (see page 108).</p> <div data-bbox="855 788 1145 1016" style="text-align: center;">  </div>
4	Secure the cable drum brake again.

*Operation via generator or battery power supply (optional)*

If there is no possibility to tap mains power in the immediate vicinity of the deployment location, the measuring system can also be operated via an adequately dimensioned generator system or battery voltage supply.

An integrated battery power supply provided Megger automatically takes over the supply of the measuring system if the test van has not been connected to mains voltage.

The generator systems provided Megger are typically vehicle engine driven systems, which must be commissioned manually if necessary. To do this, the vehicle must be put into neutral, the generator switched on and, if necessary, the engine speed must be regulated. The exact procedure differs depending on the generator and vehicle model.

When the generator is in operation, the system automatically draws its operating voltage from the generator. This also applies if the test van is connected to the mains power supply.

---



For detailed information on the handling, specification and safety of the systems provided, refer to the manufacturer's product information.



---

### 3.2.6 Connection of the external safety device (optional)

**Purpose** Using the external safety device, the status of the system can be indicated outside the test van and the HV processing can be interrupted or blocked using the EMERGENCY OFF switch and key switch.



**Description** The following figure shows the optional external safety device:



Part	Description
①	<b>Green signal light</b> Lights up when the system is switched on but not in high voltage operation.
②	<b>Red signal light</b> Lights up as soon as high voltage can be generated. All discharge and earthing devices are open, and the test object must be treated as live.
③	<b>HV interlock key switch</b> <div style="display: flex; align-items: center;">  <div style="margin-left: 10px;">High voltage unlocked</div> </div> <div style="display: flex; align-items: center; margin-top: 10px;">  <div style="margin-left: 10px;">High voltage locked. In this position, the key can be removed, and the system secured against unauthorized high-voltage operation.</div> </div>
④	<b>EMERGENCY OFF switch</b> Pressing the EMERGENCY STOP button will shut off the high voltage immediately and discharge the test object before earthing the HV output. The plug sockets in the control room will still be live.

*Connection of the external safety device*

Proceed as follows to connect the external safety device:

Step	Action
1	<p>If the external safety device connection cable is provided on a cable drum, first disconnect the system from the cable drum.</p> 
2	<p>Unroll the connection cable.</p>
3	<p>Place the external safety device so that it is accessible and visible near the test van and connect the connection cable to the appropriate socket.</p>
4	<p>If necessary, reconnect the connection cable coming from the system to the socket on the cable drum.</p> 

### 3.3 Use of USB accessories

	<p><b>CAUTION</b></p> <p><b>Risk of interference</b></p> <p>To prevent malfunction of or even damage to the Teleflex VX, observe the following instructions:</p> <ul style="list-style-type: none"> <li>• Do not use extension cables when connecting USB accessories.</li> <li>• During HV operation, no loose USB connection cables may be inserted into the USB ports of the Teleflex.</li> </ul>
--	--

The Teleflex VX has two Type-A USB ports to which the following accessories can be connected:

Class	Description
Input devices	<p>For convenient data entry, both corded and cordless keyboards and mice can be connected.</p> <p>Depending on whether a hardware mouse and/or keyboard is connected, the on-screen keyboard and the mouse pointer can be activated / deactivated in the basic settings of the software (see page 52).</p> <p>It is also possible to connect a wireless keyboard and/or mouse with a suitable USB dongle.</p>
USB mass storage	<p>For the import and export of measured data and reports, USB mass storage (for example USB flash drive and external hard drives) can be connected.</p>
Printer	<p>For direct printing of measured data and reports, a printer can be connected. However, the selection of compatible printers is limited by the drivers installed on the system.</p> <p>Before buying a new printer, please contact your Megger sales partner for a list of supported devices.</p>

### 3.4 Setting up switch-on standby

After the test van has been connected or a change made to the test object activation, the connection cables must be led through the cable guide to the outside, as shown in the following figure:

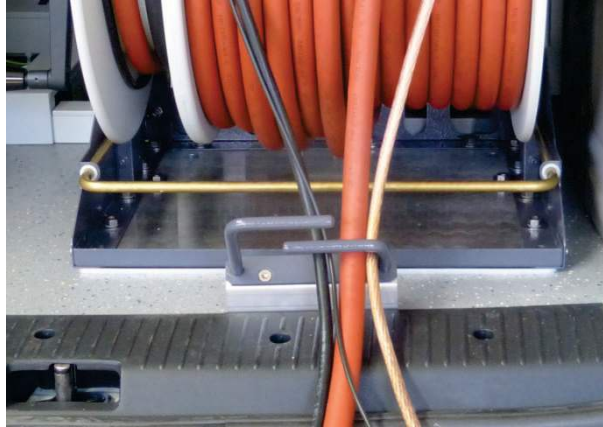

After the rear doors of the test van have been closed, it is ready to be turned on. Assuming that the connection was established properly, and good earthing conditions were ensured, the conditions of the safety circuit are thus also fulfilled.

### 3.5 Switching on the test van

*Switching on the test van* After the test van has been connected as prescribed, the control voltage can be switched on with the illuminated main switch **7** on the control panel.

*Safety circuits* Directly after switching on the test van, the requirements of both safety circuits are constantly monitored for deviations. If all the requirements of **safety circuit I** are fulfilled, the Teleflex VX is supplied with power and, without any further presetting's, a pulse reflection measurement via the optional Teleflex LV cable can be carried out.

For high voltage operation, the requirements of **safety circuit II** must also be fulfilled, in addition. Deviations from the requirements are indicated by the following messages on the Teleflex VX display:

Message	Cause	SC I	SC II
<b>HV Unit disabled by Emergency Off</b>	One of the EMERGENCY OFF switches has been activated.		
<b>Error ground resistance</b>	Resistance between the vehicle chassis and surrounding ground (auxiliary earth) is too high (>15 ±2 kΩ).		
<b>Input voltage out of range!</b>	The supply voltage is not within the permitted range.		
<b>Voltage raise of protective earth</b>	Voltage-time integral between the vehicle chassis and the surrounding ground is too high. Check the quality of the connection to protective earth and operational earth. This message may also indicate that the test van is directly above the fault position.		
<b>Door is open</b>	The rear door of the test van is open.		
<b>HV Unit disabled by Interlock Key</b>	High voltage operation has been disabled using the key switch <b>3</b> on the control panel, or by means of the external safety device (see page 31).		
<b>Cable shield not grounded</b>	Resistance between the system earth and protective earth is too high (>10.5 ±2 Ω).		

## 4 Operating the test van in general

### 4.1 Switching high voltage on and off

*Switching high voltage on* If the requirements of both safety circuits have been met and the operating mode has been started using menu item  after setting the phases, the green illuminated “HV ON” push-button  on the control panel signals readiness for HV enabling.

Pressing the push-button makes the high voltage ready for switching on. The “HV ON” push-button goes off and the red “HV OFF” button  signals the new switching status. High voltage is not yet being generated, but the earthing switches are open and all individual devices which are needed for the operating mode are being supplied with voltage.

If the green “HV ON” push-button is not pressed within 15 seconds, it goes off. In this case the operating mode must be restarted before the high voltage can be enabled.

*Switching high voltage off* HV operation can be terminated at any time immediately by pressing the red illuminated „HV OFF” button .

The HV devices are switched off and the test object is discharged. The discharge switch as well as the delayed triggered earthing switch are gravity-operated, so that even in the event of a power failure the safe discharging of the test van and the test object is guaranteed.

The described discharge is also carried out in the following circumstances:

- Opening the rear doors
- Activating an EMERGENCY OFF switch
- Power failure

If the test van is equipped with the optional residual voltage indicator, the de-energised status of the measuring circuit can also be verified on the analogue residual voltage indicator  as well. In operating modes where the voltage is generated by supplied individual devices (e.g. MFM-10-M, Surge Unit 3/6/12 kV), the voltage will not be displayed!

*Locking high voltage* The control panel is equipped with a key switch  that can prevent switching on high voltage. The switch can be set to the following positions:



High voltage unlocked.



High voltage locked. In this position, the key can be removed, and the system secured against unauthorised high-voltage operation.





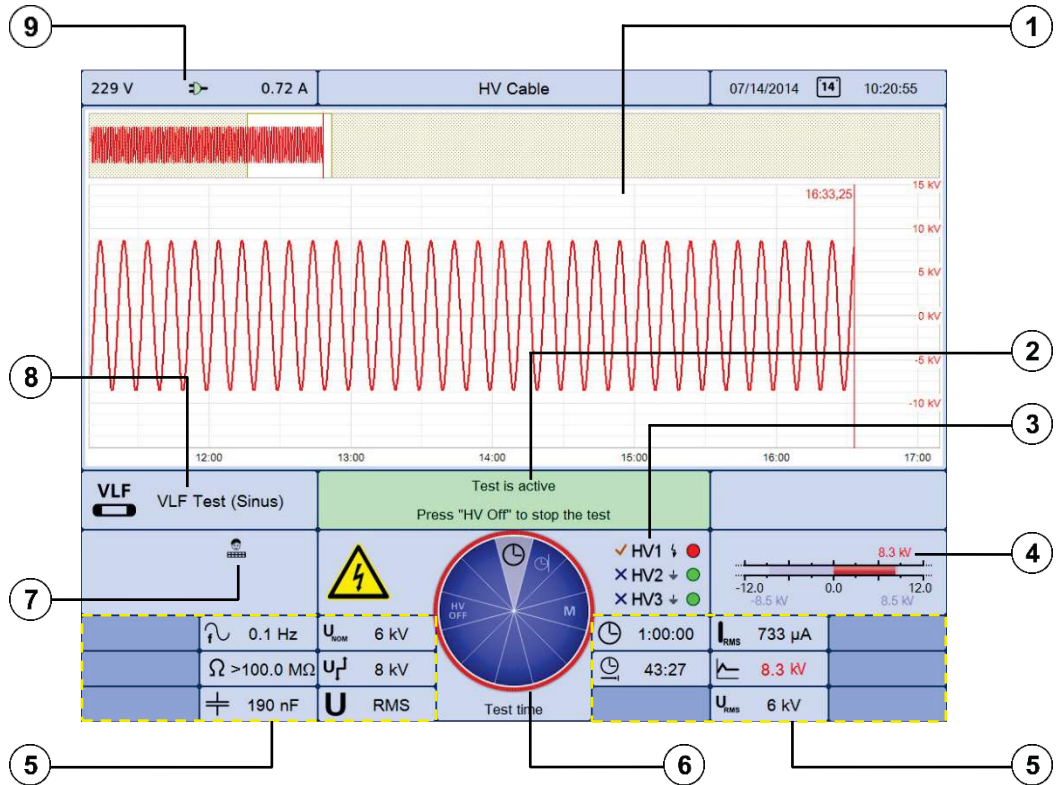

## 5 Operating the Teleflex VX

### 5.1 Screen layout

The following figure shows the typical screen layout:



Segment	Description
①	Traces for current measurement or loaded measurements. The display is split up into a general overview (top) and in an enlarged section (bottom).
②	Current status messages and information on the next step required in the test sequence.
③	Information on the states of the high voltage outputs. The symbols indicate the following states: <ul style="list-style-type: none"> <li> The HV output has not been selected for the upcoming / running measurement.</li> <li> The HV output has been selected for the upcoming / running measurement.</li> <li> High voltage generation is switched off and the HV output is discharged.</li> <li> The resistor discharge is cancelled here. High voltage is active!</li> </ul>
④	Voltage display bar graph Blue bar: Set value Red bar: Actual value

Segment	Description
<p>⑤</p>	<p>The display elements arranged in the lower area of the screen may contain the following information:</p> <ul style="list-style-type: none"> <li>• Set measurement parameters</li> <li>• Current measurement values, which are continuously updated as the measurement progresses</li> <li>• Legend of traces currently shown in display (see page 47).</li> </ul> <p>Information (such as, e.g. measurement values) which apply for a particular trace only, is shown in the respective colour.</p>
<p>⑥</p>	<p>Selection menu (see page 39)</p>
<p>⑦</p>	<p>Current system state</p> <ul style="list-style-type: none"> <li> The system is currently in standby.</li> <li> Pulse reflection measurement currently under way.</li> <li> The measurement was stopped and the traces frozen.</li> <li> The device is in measurement operational readiness and waiting to be triggered.</li> <li> The user operating the system has successfully logged into the administration menu (see page 54) and identified himself / herself as administrator.</li> </ul>
<p>⑧</p>	<p>Current operating mode</p>
<p>⑨</p>	<p>Power source and parameters</p> <ul style="list-style-type: none"> <li> Mains operation</li> <li> Generator operation</li> </ul>

## 5.2 Basics of control

*Selection menu* Navigation within the menus is affected almost entirely from the circular selection menu:

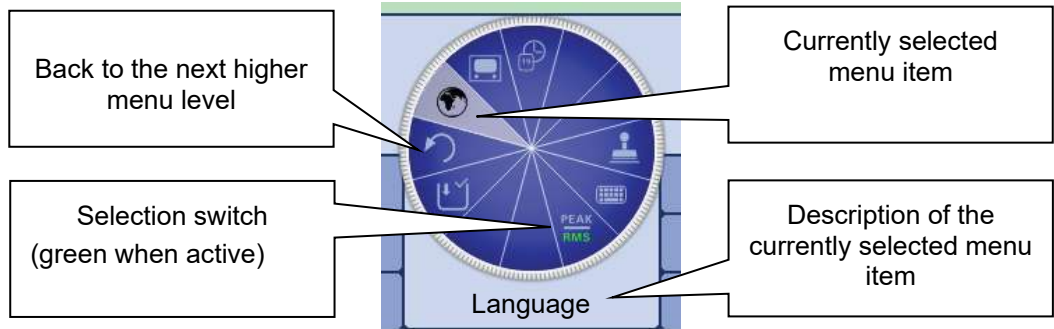

*Operation with rotary encoder* The Teleflex VX can be operated using the rotary encoder as follows:

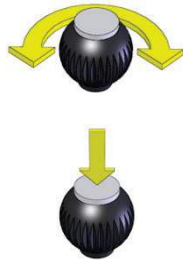

- Select the required menu item
- Increase or decrease the value of a variable parameter
- Select an option from a selection list
  
- Call up the selected menu item
- Confirm the setting or the selection made

The four side menus are retrieved either by tilting the rotary encoder:

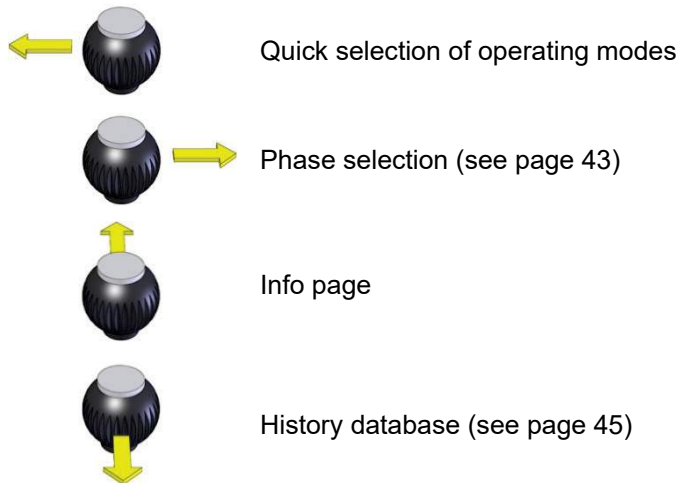

Operation with mouse and keyboard

Operation using the mouse and keyboard is as follows:

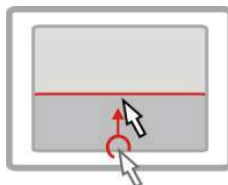
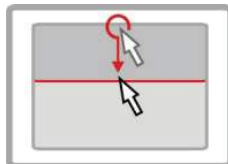
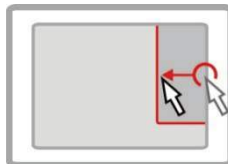
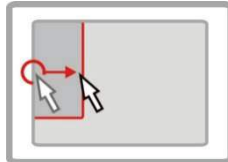

- Select the required menu item
- Increase or decrease the value of a variable parameter
- Select an option from a selection list
- Call up the selected menu item
- Confirm the setting or the selection made

Quick selection of operating modes

Phase selection (see page 43)

Info page

History database (see page 45)

*Operation using the touchscreen* If the device/system is equipped with a touch-sensitive display, then the software can also be operated just by using your fingers.

Briefly tapping on the buttons in the various menus, and tapping and holding the buttons in isolated cases, allows the respective functions to be activated in the same way as the rotary encoder control.



The four menus at the side can be opened by a swiping motion.

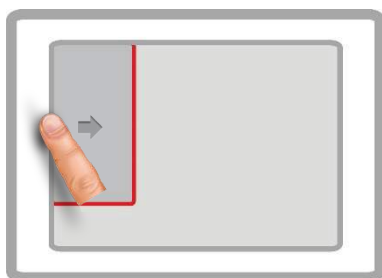

Quick selection of operating modes

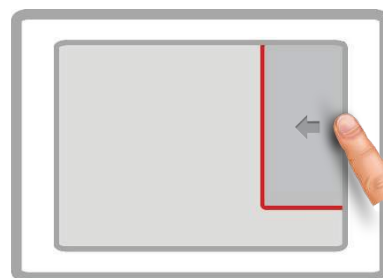

Phase selection (see page 43)

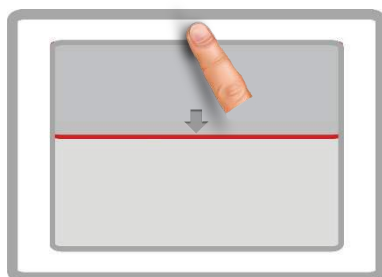

Info page

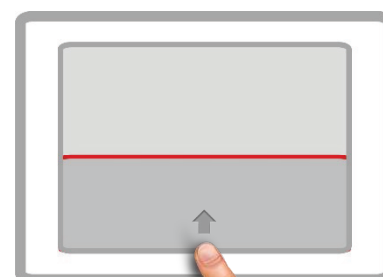

History database (see page 45)

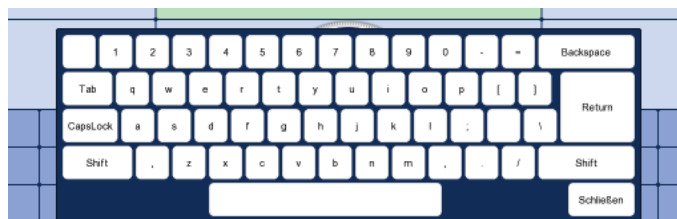

Whenever character strings need to be entered or changed, an on-screen keyboard appears at the lower edge of the display:



If wanted, the touch functionality and the on-screen keyboard can be disabled in the basic settings (see page 52). The latter is particularly useful, if a hardware keyboard is connected.

*Dialog boxes* A few settings, which require values to be entered, are not made directly using the selection menu, but rather in a separate dialog box.





Using  and  the user can switch back and forth between the individual buttons in a dialog box. Each active button is then highlighted in white, or it is surrounded by a red frame. Whenever the selected button requires letters or digits to be entered the screen keyboard automatically appears (touchscreen required), and it can then be used to make the entries.

To close a dialog box, the corresponding button must be selected and then the rotary encoder pressed.

### 5.3 Quick selection of operating modes –

Using  the quick selection menu can be accessed (as well as closed) at any time. The menu provides direct access to all the available operating modes.

**5.4 Phase selection - **

*Opening phase selection menu* The selection menu for the phase(s) involved in the measurement opens automatically as soon as an operating mode is entered. It can also be opened manually at any time via .

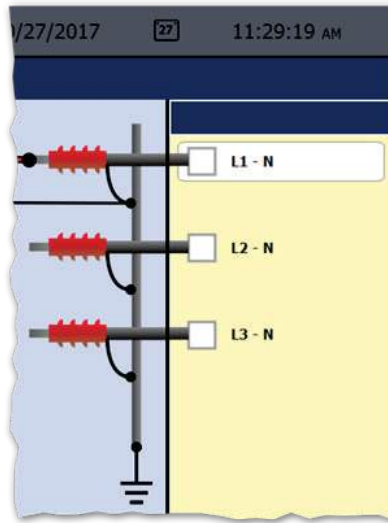

*Selecting the phases* The desired phase can be marked for selection by turning the rotary encoder and then selected or deselected by pressing it.



- Option is active
- Option is not active

The options that are displayed during phase selection and the number thereof that can be selected at the same time depends on both the operating mode and the number and type of cable reels.

*Correcting the connection situation* Immediately after at least one option has been selected, the recommended connection situation for the current phase selection is shown on the left next to the selection window, as shown in the example below.



It must be checked whether the connection to the test object that is shown corresponds with the actual connection situation. If this is not the case, the electrical connection must be adapted accordingly.

Depending on the operating mode and the available cable reels, changes can also be made to the connection schematic shown using the  and  buttons within the technical permitted scope. In this way, for example, test object phases can be individually connected / disconnected, the assignment between patch panel output and test object phase can be changed, or bridges installed at the test object (for simultaneous testing of multiple phases) can be added.

*Confirming the phase selection*

The phase selection menu can only be closed once a valid selection has been made. By closing the menu via , the active selection is confirmed. Until the actual start of the measurement, the selection menu can be called up again and adjusted.



Make sure that the phase selection matches the actual connection situation! Otherwise, the measuring data will be stored with incorrect phase details whereupon the data will not be able to be correctly assigned afterwards.

*Selecting the phase in systems with additional system outputs*

Depending on the configuration of the system, the outputs **LV** (Teleflex LV cable), and **HV4** (output for 80/100 kV Surging mode) may be present in the phase selection menu alongside outputs **HV1** to **HV3**.

For the **LV** outputs, the selected operating mode is the only determining factor for which output is used to select the phase in the phase selection menu. This prevents erroneous selections.

Systems with the option "80/100 kV Surging" are the only type of system in which the selection of a certain HV output in ICE and surge operating modes has a direct influence on the measurement parameters. If the system is connected via outputs **HV1**, **HV2**, or **HV3**, the maximum surge level that can be selected is 50 kV. To operate at the 80/100 kV surge level, the system must be connected through the **HV4** output.

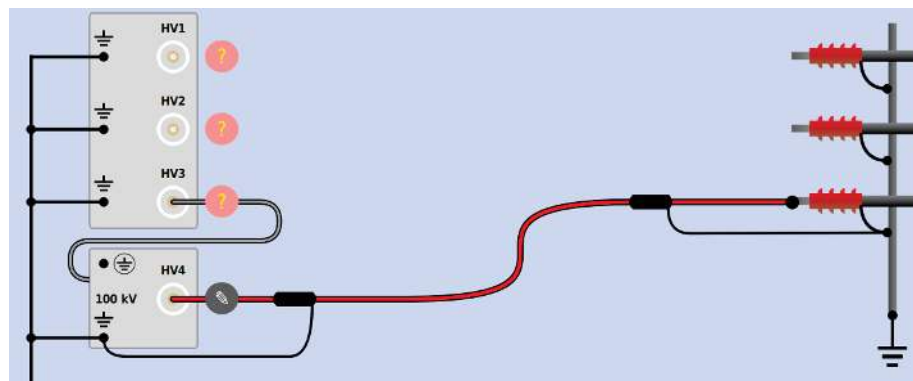

If the actual connection status does not fulfil the prerequisites for 80/100 kV surge operation (see page 26), the operating mode cannot be activated, and a corresponding message is displayed.

## 5.5 History database -

**Purpose** Each conducted measurement is temporarily stored in the History database, and it can be retrieved from there again. This enables the user to access old traces and to compare them with the current traces. The parameters under which the measurement was conducted are also shown.

**Browsing the history database** Via  the history database can be called up at any time.

The measurement data records are organised by date in sub-directories.

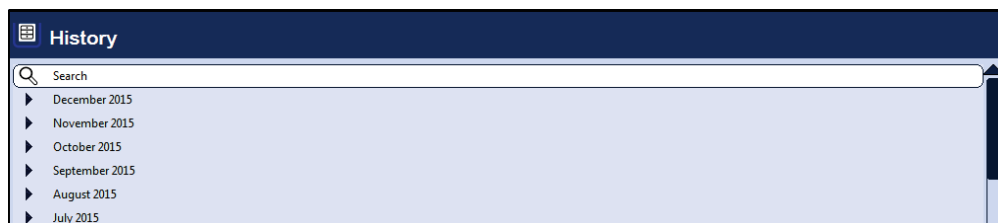

After the desired month and then the desired day have been selected, the measurement data records registered on this days can be searched through and retrieved.

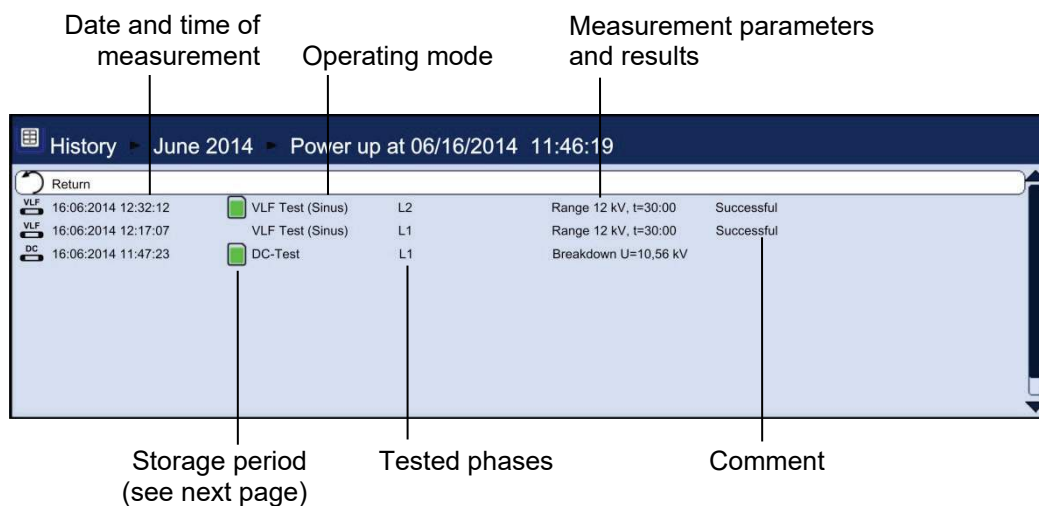

Via the  list entry you can always return to the next directory level up.

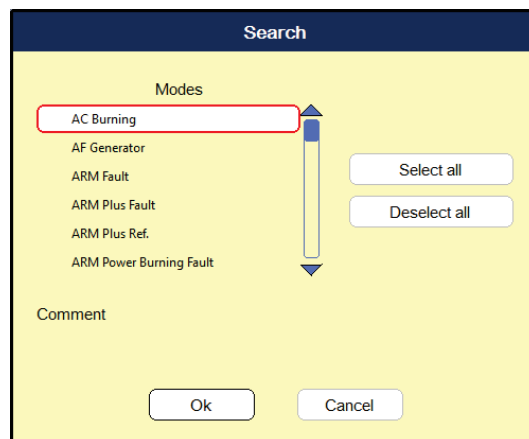

Via the  list entry you can reach the search mask using which you can search for particular operating modes and comment entries through the data records of the current directory and all sub-directories.



If you are searching for both an operating mode and comment entry at the same time, only those results which fulfil both criteria will be displayed.





Holding down the  button will cause the search criteria to be discarded and all the data records to be displayed again.

**Storage period** The default setting stores the measurement data for 90 days in the history database. The following symbol indicates how long a measurement has already been stored:

Symbol	Description
No symbol	The data record has been conducted just recently. An automatic deletion is not imminent.
	The data record is either imported or permanently stored (see page 61).
	Automatic deletion of the measurement data record is imminent (less than 5 days remain).

To prevent the imminent deletion of a specific measurement data record, it only needs to be called up from the history database and permanently saved via the **M** menu item (see page 61).

**Managing data records** If a data record or an entire folder is to be exported or deleted, it must be selected first using the rotary encoder and then has to be marked appropriately using .

Symbol	Description
	The data record or the folder (incl. all data records in it) is marked for deletion.
	The data record or the folder (incl. all data records in it) is marked for export.
	Several data records within the folder have been marked for deletion.
	Several data records within the folder have been marked for export.
	The folder contains both data records marked for deletion and data records marked for export.

---



---

 After selection of the measurements the data deletion or export process must be initiated in the data menu (see page 51). Otherwise, the markings will expire the next time the software is started up.

---



---

*Accessing measurement data from the history database* To access curves and data from old measurements, first access the history database and then use the rotary encoder to select the respective measurement from the directory structure. **Briefly pressing** the rotary encoder enables all the curves and measured data for this measurement to be loaded. To this end, the software proceeds as follows:



- If the operating mode currently selected is the same operating mode in which the loaded measurement was recorded in, the accessed curves are shown together with the currently recorded curves. This enables the results of different measuring operations to be easily compared.
- If the current and the loaded measurement are not of the same operating mode, the current measurement is automatically ended and only the loaded measurement is displayed.
- If there are not enough free slots to display the loaded curves, the currently recorded curves are overwritten. To avoid this, it is advisable to select curves from the History database one by one (see below) so that you can assign them individually to slots that are free or no longer needed.

If you want to repeat a test, you can use this function to first access the measured dataset from the previous test from the history and then launch a new test with the same test parameters. Because the curves from the previous test also remain on the display after the new test has begun, you can conveniently compare these with those of the current test.

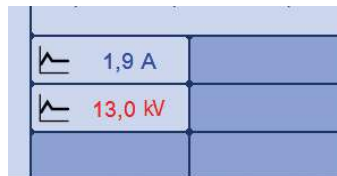
The colour-coded legend on the bottom right edge of the screen provides information relating to the measured values of the curves currently displayed.



Current and loaded curves can be differentiated between using the symbols in front of them.

Symbol	Description
	Curves which were recorded during the measurement in progress.
	Curves which have been accessed from the history database.













By **Holding down** the rotary encoder a context menu can be opened from which the following special functions can be accessed:

- Add / edit a comment for the measurement
- Access special measurement data or only individual traces of this measurement (possible in certain modes only)

## 5.6 System settings -





The System menu can be access directly through the menu item when in the main menu, and it contains the following menu items:

Menu item	Description
	Submenu for managing the measurement data (see page 51).
	Basic settings (see page 52)
	<p>Default values can be adapted for nearly all the system settings. If user management (see page 56) is active, then each user can define and store his / her own default values. These defaults are then loaded each time the system starts or a user logs in.</p> <p>The submenu contains the following items:</p> <ul style="list-style-type: none"> <li> This menu item enables the current settings to be stored as default values. Naturally, only the changes made during this session are taken into consideration.</li> </ul> <hr/> <p> When saving the default values, note that all values that have been changed since the last system start are saved, which means that you might inadvertently save some changes that you do not want. To be on the safe side, you can first reload the current defaults (see below), make the required settings and then save them.</p> <hr/> <ul style="list-style-type: none"> <li> This menu item can be used by the current user to reload his / her stored default values.</li> <li> This menu item restores the factory settings.</li> <li> This menu item enables the default values for the current user to be exported as XML files to the <i>DefaultValues</i> directory of the inserted USB flash drive.</li> <li> This menu item can be used to import defaults values that are stored on an inserted USB flash drive into the system. The imported values then become immediately applicable. When user management (see page 56) is active, the imported default values are only applicable for the user currently logged on.</li> </ul>
	Service menu which can only be accessed by a service technician.
	The administration menu (see page 54) enables a user with the appropriate permissions to access extended system functions.

Menu item	Description
	<p>This submenu enables various settings to be made for scale graduation on the X-axis and for entering the propagation velocity. It provides the following menu items:</p> <p> Depending on the setting of this switch, the X-axis is either scaled in seconds (runtime) or in length units (distance).</p> <p> <u>Only available when the X-axis is scaled in length units (see above)</u> This menu item can be used to switch the unit of the X-axis between meters and feet.</p> <p> <u>Only available when the X-axis is scaled in length units (see above)</u> To achieve reliable distance details, knowledge about the exact signal propagation velocity for the test object is essential. This can be specified in two different ways:</p> <ul style="list-style-type: none"> <li>• <b>NVP</b> (Nominal Velocity of Propagation) - The signal propagation velocity is stated relative to the speed of light, e.g. NVP 0.53 = 0.53 x c.</li> <li>• <b>SPEED</b> - The signal propagation velocity is stated with half the actual propagation speed (the cable's so-called V/2).</li> </ul> <p>Depending on the above settings, a default propagation velocity value can be defined using the menu items <math>\frac{V}{2}</math> and <b>NVP</b> respectively. This value is then preset whenever a measurement is started.</p>
	<p>Submenu for displaying and exporting important system information.</p> <p> Information on software version</p> <p> Information on system hardware and the current IP address</p> <p> This menu item enables messages stored in the system log to be displayed).</p> <p> This menu item enables the system log to be exported to an inserted USB flash drive (<i>SystemLog</i>-directory).</p> <p> Option for checking key assignment for a connected USB keyboard.</p>
	<p>This menu item can be used to define whether the system information is to be printed through a connected printer or saved as a PDF file (into the <i>PdfFiles</i> directory of an inserted flash drive).</p> <hr/> <p> To enable system information to be printed out directly, the type of printer connected must be configured beforehand (see page 52).</p> <hr/>











### 5.6.1 Data menu -











The Data menu enables stored measurement data to be imported, exported or deleted. It contains the following menu items:

Menu item	Description
<b>DEL</b>	Menu item to enable measurement data records to be deleted from the History database. The measurements to be deleted must be marked beforehand (see page 47).
 <b>EXP DATA</b>	Menu item that enables measurement data records from the History database to be exported to the inserted USB flash drive ( <i>Winkis</i> directory). The data records to be exported must be marked beforehand (see page 47).
 <b>IMP DATA</b>	Menu item to enable measurement data records / logs to be imported. To do so, a window is opened in which the user can navigate through the directories on the plugged-in USB flash drive.
	List of common cable types that can be extended by own cable and insulation types. This eliminates the need to manually enter the propagation speed during cable fault pre-location. Instead, the appropriate cable type can simply be selected from the list and its stored propagation speed automatically applied.  Two filters (cable type and cable insulation) can be used to limit the number of cables displayed.  Saved cable types can only be edited or deleted with administration rights (see page 54).
 <b>EXP</b>	Menu item to enable the cable list (see above) to be exported to a USB flash drive ( <i>Cables</i> directory).

## 5.6.2 Basic settings -

The following menu items can be used to adapt the software's basic settings:

Menu item	Description
	<p>Sets the language.</p> <p>Select the desired language by turning the rotary encoder and activate by pressing it. The language selection is immediately active.</p>
	<p>This submenu enables the following screen settings to be made:</p> <ul style="list-style-type: none"> <li data-bbox="539 595 1457 663"> This menu item enables the user to select one of the available screen layouts.</li> <li data-bbox="539 674 1457 741"> This menu item can be used to change the line thickness for the traces to meet one's own requirements.</li> <li data-bbox="539 752 1457 819"> For systems with a touch sensitive display, this menu item can be used to enable / disable touch functionality.</li> <li data-bbox="539 831 1457 898"> Menu item to show/hide the mouse cursor. To operate the software via a connected mouse, the mouse cursor must be enabled.</li> <li data-bbox="539 909 1457 947"> Menu item to enable / disable the on-screen keyboard.</li> </ul>
	<p>Date and time.</p>
	<p>This menu item enables a connected printer to be selected from a variety of supported printers.</p> <hr/> <div data-bbox="539 1137 1457 1216" style="border: 1px solid black; padding: 5px;"> <p> Before buying a new printer, please contact your Megger sales partner for a list of supported printers.</p> </div> <hr/>



Menu item	Description
	<p>This menu item enables the following functions that influence the measurement sequence to be activated or deactivated:</p> <ul style="list-style-type: none"> <li data-bbox="568 394 1369 472">  If this option is activated, all three phases are automatically selected upon entering the <math>\Omega</math> operating mode.                 </li> <li data-bbox="568 483 1426 584">  If this option is activated, all three phases are automatically selected upon entering a TDR operating mode (this only applies for TDR measurements via the LV cable).                 </li> <li data-bbox="568 595 1453 685">  If this option is activated, the phase selection is always reset upon exiting the operating mode and must be conducted again upon each return.                 </li> <li data-bbox="568 696 1401 775">  If this option is activated, the selected voltage range is always reset upon exiting / changing the operating mode.                 </li> <li data-bbox="568 786 1433 853">  If this option is activated, multiple phases can be selected in <b>ARM</b> operating mode.                 </li> <li data-bbox="568 864 1445 931">  Activates / deactivates automatic scaling adjustment of the X axis as soon as a trace is recorded.                 </li> <li data-bbox="568 943 1445 1010">  Activates / deactivates automatic gain adjustment of the Y axis as soon as a trace is recorded.                 </li> <li data-bbox="568 1021 1445 1088">  Activates / deactivates the automatic positioning of the marker on the suspected fault location as soon as a trace is recorded.                 </li> </ul>
	<p>Layout of the connected keyboard.</p>
	<p>This menu item enables the currently logged-on system user to be changed. Once a new user has been selected, the new user's default settings are then loaded. The menu item is only available if at least one user exists in the database. The administrator can manage user accounts in the administration menu (see page 54).</p>

### 5.6.3 Administration menu - (administration password required)







**Purpose** The administration menu is password-protected and provides access to advanced system settings such as the user administration, as well as update and backup functions.

The software's menu structure has concealed menu items added to it when administration rights are issued. These enabled functions, which are only rarely used during day-to-day operation of the device, are described in greater detail throughout the course of the manual.

**Access** To open the administration menu, you must first enter the password. Proceed as follows:

Step	Action
1	Select menu item  , to access the Control Panel and then select menu item  .
2	Select menu item  . <b>Result:</b> The password entry dialogue appears in the display.
3	Enter the password and confirm your entry with <b>OK</b> . <b>Result:</b> If you entered the password correctly, the menu items of the administration menu appear (see below). If your entry is incorrect, you must repeat the procedure from <b>Step 2</b> .

**Menu items** The administration menu contains the following menu items:

Menu item	Description
	These menu items can be used to back up or update (see page 55) the individual modules of the software.
	This menu item can be used to completely empty the database, i.e. all measurement results, users, cable types and system logs are deleted. However, calibration and configuration data are retained. After you select this function, the system is restarted. After the restart, you must once again confirm that you want to reset the database. Before resetting the database, you should always make a backup (see page 55).
	Menu item used to manage the users accounts (see page 56) of the system.
	This menu item can be used to enable operating modes and functions in the software that have not yet been activated. An appropriate unlock key is required for the enabling process. Please contact your local Megger sales partner for more information on activating a function or an operating mode.
	Menu item to activate/deactivate the connection lead calibration mode (see page 57).
	Menu item used to disable administrator rights and to protect the administration menu with a password again.

**5.6.3.1 Backing up and updating data -  $\frac{UP}{DATE}$  |  $\frac{BACK}{UP}$**

*Data backup* Menu item  $\frac{BACK}{UP}$  can be used to back up all the files required to recover the system.

Depending on the type of system, the following files are exported to the inserted USB flash drive directory *Backup\_<serial number>* during a backup:

File	Explanation
<i>application_&lt;version&gt;.img</i>	The application file itself
<i>printforms.tar</i>	All print templates, log templates and logos
<i>Languages*.tar</i>	Language file that contains all the available menu languages in the system.
<i>SebaKMT.cfg.xml</i>	Configuration file
<i>backupDB.sql</i>	A backup of the database, containing the saved measurement data, cable database, user database and the default values.
<i>*.txt</i>	Log files of the system and the included test attachments.

Because the *backupDB.sql* file contains the complete database and therefore can only be loaded again in its entirety, the following data can also be exported separately using the menus so that they can be transferred separately (e.g. to another system):

- Measurement data (see page 51)
- User account data (see page 56)
- Default values (see page 49)
- Cable data (see page 51)







*Loading software modules* Menu item  $\frac{UP}{DATE}$  can be used to install the individual software modules (see above) into the system. This way, you can restore or update modules, or transfer them to another system.

When you open the function, a file browser appears to help you navigate through the files on the plugged-in USB flash drive. Only the files which the system identifies as software modules and which the user is authorized to load are displayed.

This means that the application itself, the database and the configuration file can only be loaded by users with enhanced administrator rights. If you do not yet have the appropriate rights, please contact your local Megger sales partner.

## 5.6.3.2 User administration -

User administration allows you to set up various user accounts on the system, so that each user can adjust the default values and the way the system behaves according to his own preferences.



Menu item	Description
	<p>A new user can only be created if a username is entered. You can also limit the maximum voltage that the user can adjust and protect the account with a password.</p> <p>If you do not specify a password, the user does not need to enter a password when logging in, which makes the procedure quicker.</p> <p>The default values for the new user are the same as the factory settings. If necessary, you can import (see page 49) the default values from another user account (or even another system).</p>
	<p>This menu item can be used to edit the name, voltage range and password of a user.</p>
	<p>This menu item can be used to delete individual users from the user database. If the last user has been deleted, the user management is deactivated and there is no longer a login procedure when the system is started.</p> <hr/> <div data-bbox="533 1034 600 1115" style="border: 1px solid black; padding: 2px; display: inline-block;">  </div> <p>You can only delete the last user by interrupting the login.</p> <p>When deleting a user, his default values are lost. Therefore – particularly for the last user – you should export the default values beforehand (see page 49) beforehand.</p> <hr/>
	<p>This menu item allows you to export a selection of user profiles from the system together with the respective standard values as an XML file to the inserted USB flash drive's <i>User</i> directory.</p>
	<p>This menu item can be used to import user profiles that are stored on an inserted USB flash drive into the system.</p> <p>This does not affect existing users. If two usernames are the same, the system asks whether you want to overwrite or keep the existing user in the system.</p>

### 5.6.3.3 Connection Lead Calibration -

**Necessity** A properly calibrated connection lead (HV connection cable and LV connection cable) ensures the accuracy of all operating modes which function according to the TDR principle (Teleflex, IFL and all ARM modes). The length of the connection lead is not only automatically hidden from the visible diagram area, but also automatically subtracted from the calculated distance specifications.

As a principle, a calibration was already performed using the connection cables supplied during the final test. A repeat calibration should only be performed when one of the connection cables was replaced with a cable with a different length. In this case, an individual calibration must be performed for all respective operating modes and phases with a signal path which is affected by the cable replacement.

**Procedure** To calibrate a pre-measuring cable, proceed as follows:

Schritt	Aktion
1	Activate calibration mode using the menu item  in the administration menu.
2	Start the operating mode for which you wish to perform the calibration.
3	Select the phase for which you wish to perform the calibration.
4	Perform a measurement with the end of the connection cable open.
5	Exit the operating mode and then open it again immediately. Select the same phase as in <b>Step 3</b> .
6	Open the trace recorded in the history database beforehand (see page 45).
7	Short circuit the connection cable at its end and perform another measurement.
8	Select the menu item  and move the red cursor exactly to the point at which both traces diverge. Then press the rotary encoder and keep pressing it until the new zero position is applied.
9	Repeat the procedure, if necessary, for other phases and operating modes.
10	Deactivate calibration mode using the menu item  in the administration menu.

## 6 Conducting measurements

### 6.1 Good to know ...

#### 6.1.1 Propagation velocity

*Introduction* To enable the exact distance between the start of the cable and the fault position to be calculated, the TDR must be aware of the propagation velocity in the cable. This velocity depends on several physical variables in the cable: insulation material and thickness, cable diameter, etc.

If the setting for the propagation velocity value is out by 2%, then the measurement result will also be out by 2%.

*Determining unknown propagation velocity* If the correct physical length of the cable under test is known, the propagation velocity can be measured. To do so, perform a pulse reflection measurement, and make sure that the end cursor is positioned exactly on the identified end of the cable. The propagation velocity is then continuously altered until the actual cable length is displayed. The propagation velocity should then be noted down for future measurements.

If the length of the cable under test is unknown because of elbows, reserves, etc., then a piece of the same cable can be measured in the workshop and the determined propagation velocity used for the cable out in the field. A reference cable such as this, however, should be at least 50 metres in length.

### 6.1.2 Pulse width

Due the attenuation and dispersion characteristics of a cable, signals get changed in amplitude and shape as runtime progresses. Naturally, this also applies to the measuring pulse and its reflections.

Narrow pulses, which contain a large portion of high frequencies, are subject to greater deformation than wide pulses. Consequently, narrow pulses are more suited for shorter ranges in which they can provide an image with higher resolution than wide pulses, whereas over larger distances they suffer from greater attenuation and dispersion. Here, wide pulses (up to 10 µs) must be used, as they are subject to significantly lower attenuation and therefore they supply a much clearer echo over longer distances.

The following table provides an overview of the pulse widths recommended for each required distance range:

Required distance range	Recommended pulse width
<100 m	20 ns
100 m ... 200 m	100 ns
200 m ... 1 km	200 ns
1 km ... 2.5 km	500 ns
2.5 km ... 10 km	1 µs
10 km ... 30 km	2 µs
30 km ... 80 km	5 µs
>80 km	10 µs

6.1.3 Typical TDR reflectograms

The following illustration shows several idealized examples for TDR reflectograms:

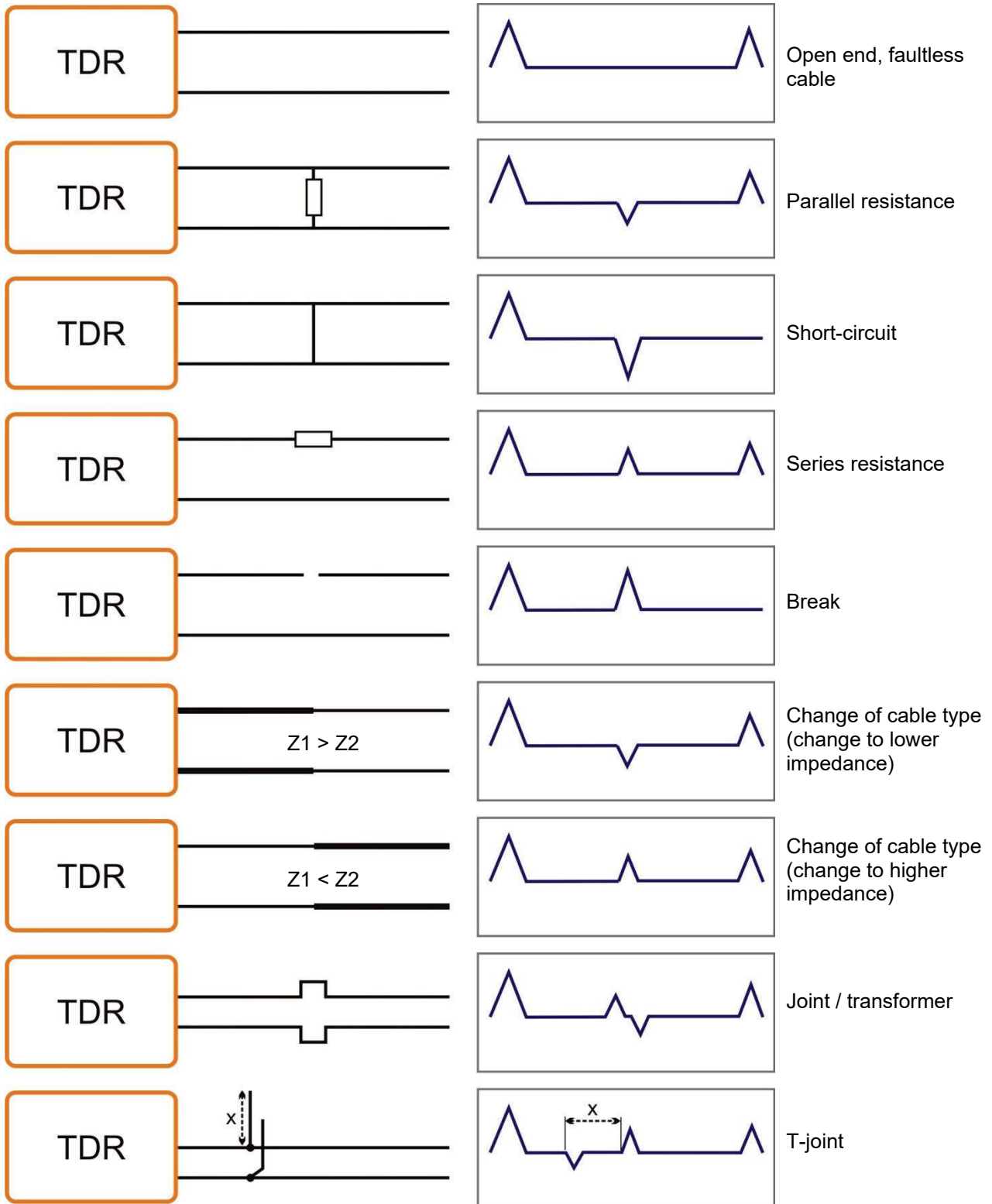

## 6.2 Standard functions









*Generally available functions* The following standard functions are available in the respective measurement menu on the Teleflex VX in all operating modes in which measurement data are recorded and displayed:

Menu item	Description
	This menu item can be used to move the cursor along the X axis. The current, voltage, time or distance values of the currently marked position are displayed in the bottom part of the screen.
	This menu item can be used to increase or reduce the visual range on the X-axis. The section aligns itself with the current cursor position here.
<b>M</b>	<p>This menu item can be used to access a list of all data records stored in the History database which match the currently active operating mode. Only the permanently stored data records are considered here. Using the rotary encoder enables a data record in the list to be selected and then accessed.</p> <p>This way, e.g. a reference trace previously recorded on the same cable can be quickly located and compared with the current trace.</p> <p>Furthermore, the menu item  can be used to store the current measurement permanently in the History database.</p>

*Standard functions for pulse reflection measurements* Due to the numerous functions, the measurement menus of all operating modes working according to the TDR principle (e.g. Teleflex operating modes, ARM operating modes, ICE and DECAY) feature two additional submenus.

In the actual measurement menu and in the Teleflex menu , all measurement parameters relevant for recording and displaying the curves as well as several additional functions are consolidated. Depending on the operating mode, these menus include a selection of the following menu items:

Menu item	Description
	<p>In all the operating modes in which the measurement has to be triggered (e.g. ARM), the respective trigger threshold can be manually adapted.</p> <p>Normally the trigger threshold is automatically pre-configured to a suitable value. If the measurement should however be interrupted by low voltage reflections which are clearly not induced by the transmitted pulses, then the trigger threshold should be manually increased. If, instead of this, no reflections are displayed at all, then it may be helpful to reduce the threshold.</p>
	<p>This menu item can be used to set the gain.</p> <p>For pulse reflection and ARM measurements, the gain can be set for the received signal. If the setting is good, the reflection for the open cable end can be clearly identified as a positive reflection.</p> <p>In the ICE and Decay operating modes, any change of the gain setting requires a new fault flash-over to be triggered for the effect to become visible.</p>

Menu item	Description
	<p>This menu item can be used to set the measurement range (X-axis). For pulse reflection and ARM measurements, the end of the cable should be visible as a positive reflection at the right-hand edge of the screen. In the ICE and Decay operating modes, the measurement range should be set to five times - ten times the cable length. Whenever the measurement range is changed, the settings for filter, pulse width, pulse amplitude and de-attenuation are automatically adapted.</p>
	<p>This menu item can be used to move the red cursor along the X-axis. By pressing and holding the rotary encoder a blue mark can be set on the current position of the cursor whereupon the red cursor can then be moved further. In this way, e.g. the real distance between two noticeable positions along the trace can be measured. Depending on the operating mode, the distance (calculated from the runtime) between the two marks is shown in one of the following fields at the lower edge of the screen:</p> <p> The <b>full</b> distance between the blue mark and the red cursor</p> <p> <b>Half</b> the distance between the blue mark and the red cursor (in Decay operating mode only).</p>
	<p>This menu item can be used to set the bandpass filter, which limits the frequency range to be measured. Interference signals outside this frequency range are suppressed. The filter value is reset to its default value as soon as one of the following operations has been performed:</p> <ul style="list-style-type: none"> <li>• change to the operating mode</li> <li>• change to the pulse width</li> <li>• change to the measurement range</li> </ul>
$\frac{v}{2}$   NVP	<p>Setting signal propagation velocity (see page 58). The type of entry depends on the system settings (see page 49). The signal propagation velocity can also be adopted directly from one of the cables filed in the Cable database (see page 51). To do so, the menu item must first be called up and then the rotary encoder pressed for at least two seconds.</p>
DEL 	<p>This menu item can be used to delete individually no longer required traces from the current display, to make it easier to read the important traces.</p>
	<p>The de-attenuation function enables the attenuation of the electrical pulses in the cable to be counteracted. This is done through amplification of the input signal which increases as the runtime increases, i.e. as distance increases the reflections are further amplified. The amplification increases exponentially up to a fixed maximum amplification. The ideal de-attenuation setting depends on the length of the cable, so the de-attenuation setting is effectively adapted whenever the measuring range is changed.</p>
	<p>This menu item can be used for all types of pulse reflection measurement to set the pulse width (see page 59) for the measurement pulse.</p>

Menu item	Description
	<p>This menu item can be used to manually set the pulse amplitude if required. For fault positions in close range, it may be helpful to experiment with lower pulse amplitudes. Conversely, higher amplitudes are suited for particularly long cables.</p> <p>With each adaptation of the distance range (X-axis) the pulse amplitude is automatically adjusted by the system to a suitable value.</p>

The trace functions menu which can be activated during a pulse reflection measurement using the menu item provides diverse options to adapt the arrangement of traces on the screen to meet individual requirements:

Menu item	Description
	This menu item can be used to move trace 1 along the Y-axis.
	This menu item can be used to move trace 2 along the Y-axis.
	This menu item can be used to move trace 3 along the Y-axis.
	This menu item can be used to move all visible traces along the Y-axis.
	<p>This menu item can be used to move the traces mapped on the display further apart from each other along the Y-axis and back in position.</p> <p> All traces are separated from each other by 50 pixels along the Y-axis.</p> <p> The traces are moved back into their original position, and they are at the same level again.</p>
	This menu item can be used to move all visible traces along the X-axis.
	The difference between trace 1 and 2 is used to calculate and display a new trace. All other traces are hidden here.
	The difference between trace 2 and 3 is used to calculate and display a new trace. All other traces are hidden here.
	The difference between trace 3 and 1 is used to calculate and display a new trace. All other traces are hidden here.
	This menu item can be used to move one of two traces along the X-axis.

---

Functions which can only be applied to traces 1 to 3 are only available when the respective slots are actually occupied.

Loading a trace from the History database into one of these slots must be done by calling up the individual trace (see page 47) instead of the complete measurement data record.

---

### 6.3 Systematics of cable fault location

*Introduction* Daily work with a cable test van is divided into the following two main areas:

- **Condition-oriented maintenance**  
Testing, diagnosis and partial discharge measurement
- **Event-oriented maintenance**  
Localization of all types of cable faults

While there are many different concepts of and approaches to condition-based maintenance, the approach described below has established itself in event-oriented cable fault location.

*Schema* The following schema illustrates the typical approach for detection, classification and location of cable faults using the methods of measurement available:

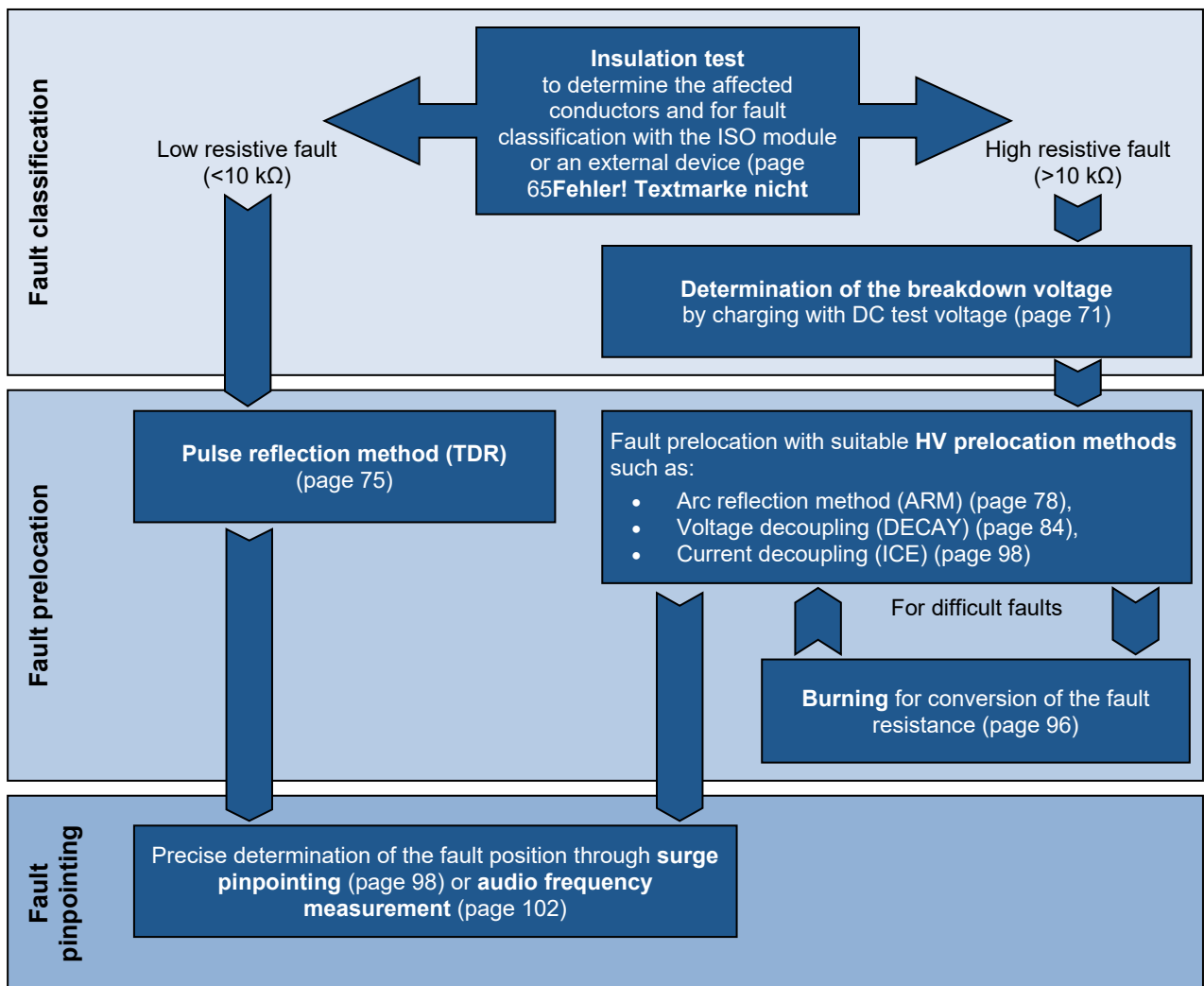





## 6.4 Insulation measurement

**Requirements** To perform an insulation test, the test van must be equipped with either the internal ISO module (measuring via the Teleflex VX) or an external insulation resistance tester (e.g. Megger). The external insulation resistance tester used may not have an output voltage exceeding 1 kV and with suitable measuring lines can either be connected to the external sockets **5** of the control panel or the external sockets in the top tray (not available in combination with the internal ISO module).

**Purpose** The first step in locating a cable fault – fault classification – should always include an insulation and resistance measurement. The measured values shed light on the characteristics of the fault and thereby narrow down the eligible prelocation methods and conductors to be examined.

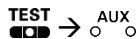
### 6.4.1 Insulation testing with an external insulation tester

**Procedure** Proceed as follows to carry out a measurement:

Step	Action
1	Connect a suitable insulation resistance tester to the external sockets in the drawer or at the control panel.
2	On the Teleflex VX, select the appropriate operating mode: <div style="display: flex; align-items: center; margin-top: 10px;"> <div style="text-align: center; margin-right: 10px;">  </div> <div>Insulation testing with an insulation resistance tester connected to one of the sockets in the drawer</div> </div> <div style="display: flex; align-items: center; margin-top: 10px;"> <div style="text-align: center; margin-right: 10px;">  </div> <div>Insulation testing with an insulation resistance tester connected to one of the sockets of the control panel</div> </div>
3	In the phase selection menu, select the phases whose insulation resistance you want to measure and close the menu using  .
4	Start the operating mode using the menu item  .
5	Geben Sie die Hochspannung über den „HV ON“-Taster frei.
6	Carry out the insulation resistance measurement with the insulation tester.  <div style="border: 1px solid black; padding: 5px; margin-top: 10px;">  For information on operating the insulation resistance tester used, refer to the corresponding operating manual.                 </div>
7	If necessary, change the phase selection on the Teleflex VX and perform further measurements.

## 6.4.2 Insulation testing with internal ISO module

*Selecting the operating mode and phases* The operating mode can be accessed directly from the main menu using the menu item  $\Omega$ .

Directly upon entering the operating mode, the phases to be tested are queried. The phases must then be configured according to the actual connection situation.

It is also possible to activate multiple options. The measurement then takes place sequentially. If one of the “phase-to-phase” options (for example **L1-L2**) is selected, a floating measurement is taken between the two phases.

The phase selection menu must then be closed using . If necessary, the phase selection can be opened later and modified.

## 6.4.3 Measurement of insulation resistance and test object capacitance

*Introduction* Based on a measurement of the ohmic insulation resistance, a basic error classification can often be made in advance.

Thus, low- and medium-resistance cable faults can, for example, be directly detected and appropriate follow-up measurements (e.g. Teleflex measurements) can be undertaken.

The deviations in resistance within a cable system can also be used in the case of high-resistance cable faults to draw conclusions about the affected phases.

It can also be helpful to repeat resistance measurements after application of certain pre-location methods (e.g. ARM, ICE) or fault conversion methods (burning) and to compare the measurement results with those stored in the database.



With the integrated ISO module, the complete measuring range from 1  $\Omega$  to 2 G $\Omega$  can, thanks to the selectable test voltages, be measured with high resolution.

The integrated resistance-dependent automatic switching of the test voltage can also be deactivated as needs require.

Test voltage	Measurement range
500 V / 1000 V	Insulation resistance: 1 k $\Omega$ ... 2 G $\Omega$
	Cable capacitance: 0.1 $\mu$ F ... 19.9 $\mu$ F
Low voltage (<6 V)	Insulation resistance: 1 $\Omega$ ... 1 k $\Omega$

*Setting the measurement parameters*

In preparation of the actual measurement, the following parameters can be set:

Menu item	Description
<div style="text-align: center;">                     AUTO                      MAN                 </div>	<p>This menu item can be used to switch between automatic and manual mode.</p> <p>In <b>automatic</b> mode, the resistance and capacitance values are always measured. A selection must only be made between the upper test voltages of 500 V and 1000 V. The system automatically switches to low voltage when determining a low-ohm resistance, since the resistance values in this measuring range can only be measured with low voltage.</p> <p>In <b>manual</b> mode, you may only determine either the resistance or the capacitance during a test. The three test voltages of 500 V, 1000 V and low voltage (&lt;6 V) are available for selection. No automatic switching between the voltages occurs during the measurement.</p>
<div style="text-align: center;">                     HR                      1000                 </div>	<p>This menu option is used to set a test voltage of 1000 V.</p>
<div style="text-align: center;">                     HR                      500                 </div>	<p>This menu option is used to set a test voltage of 500 V.</p>
<div style="text-align: center;">                     LR   </div>	<p><u>Only available in manual mode</u></p> <p>This menu option is used to set a low-test voltage (&lt;6 V).</p>
<div style="text-align: center;">  </div>	<p><u>Only available in manual mode</u></p> <p>Switching between resistance and capacitance measurement.</p>

**Measurement procedure** After the measurement parameters have been set as described above, the measurement can be started via the menu item .

Depending on the set mode, the system measures the resistance and/or capacitance values for each selected phase combination.

The results are shown in a table:

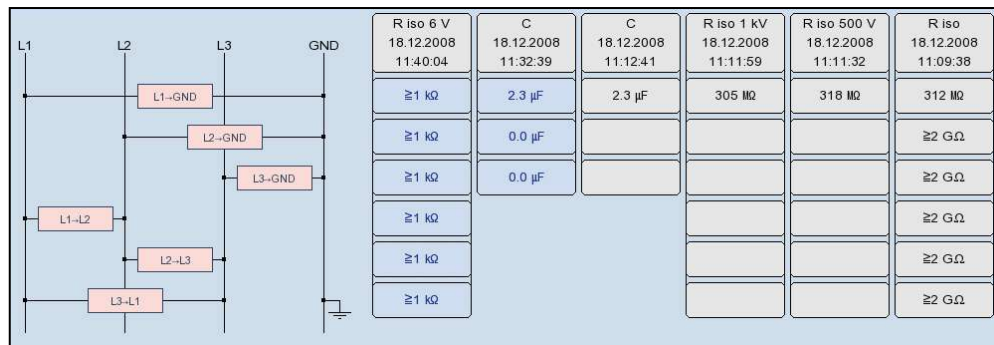

R iso 6 V 18.12.2008 11:40:04	C 18.12.2008 11:32:39	C 18.12.2008 11:12:41	R iso 1 kV 18.12.2008 11:11:59	R iso 500 V 18.12.2008 11:11:32	R iso 18.12.2008 11:09:38
≥1 kΩ	2.3 μF	2.3 μF	305 MΩ	318 MΩ	312 MΩ
≥1 kΩ	0.0 μF				≥2 GΩ
≥1 kΩ	0.0 μF				≥2 GΩ
≥1 kΩ					≥2 GΩ
≥1 kΩ					≥2 GΩ
≥1 kΩ					≥2 GΩ

The measured parameter, date and time of measurement as well as the test voltage used can be read from the table header for each measurement (column).

A new column is created for every measurement begun. The columns start on the left with the most current measured values and end on the right with the oldest measured values. A maximum of six columns can be adjacently shown. For each additional measurement, the column with the oldest measurement results is deleted.

The user can also manually delete the column with the respectively oldest measurement results via the menu item .

### 6.4.4 Time-dependent measurement of resistance -

*Introduction* Through a time-dependent measurement of resistance, the chronological change of the absorption characteristics of the insulating material and thus the degree of moisture and dirt in an insulation can be tested.

A continual rise of the recorded resistance indicates an intact insulation. A flat or downward sloping curve can indicate a dirty, moist or damaged insulation, for example.

To obtain comparable measurement results, the chronological progress can be used to calculate the well-known coefficients PI (Polarization Index) and DAR (Dielectric Absorption Ratio).

For the DAR coefficient, the value measured after one minute is divided by the measured value after 30 seconds. This coefficient should therefore be used primarily for evaluation of newer insulating materials, which exhibit a faster decline of dielectric absorption currents.

For other insulation materials, with absorption characteristics that normalize more slowly, the PI coefficients should be determined. For these, the value measured after 10 minutes is divided by the measured value after one minute.

*Opening the operating mode and selecting the phases* The time-dependent measurement of resistance is integrated into the insulation test operating mode and can be accessed using the submenu item .

Directly upon entering the operating mode, the phases to be tested are queried. The phases must then be configured according to the actual connection situation.

The phase selection menu must then be closed using . If necessary, the phase selection can be opened later and modified.

*Setting the measurement parameters* In preparation of the actual measurement, the following parameters can be set:

Menu item	Description
	Activates/deactivates the function for determining the DAR coefficients.
	Activates/deactivates the function for determining the PI coefficients.
	This menu option is used to set a test voltage of 1000 V (if possible, this voltage value should be set for the time-dependent measurement of resistance).
	This menu option is used to set a test voltage of 500 V.
	This menu option is used to specify a maximum test time of up to 15 minutes. The minimum test time is automatically set to 1 minute (when determining the DAR coefficients) or 10 minutes (when determining the PI coefficients).

**Measurement procedure** After the measurement parameters have been set as described above, the measurement can be started via the menu item .

The determined resistance values are shown on the screen during the measurement as a curve over time.

With the completion of the measurement, any DAR and/or PI coefficients that are determined are shown in a dialog box.

**Evaluation of the test results** The course of the curve itself as well as the determined coefficients can provide information on the state of the insulation.

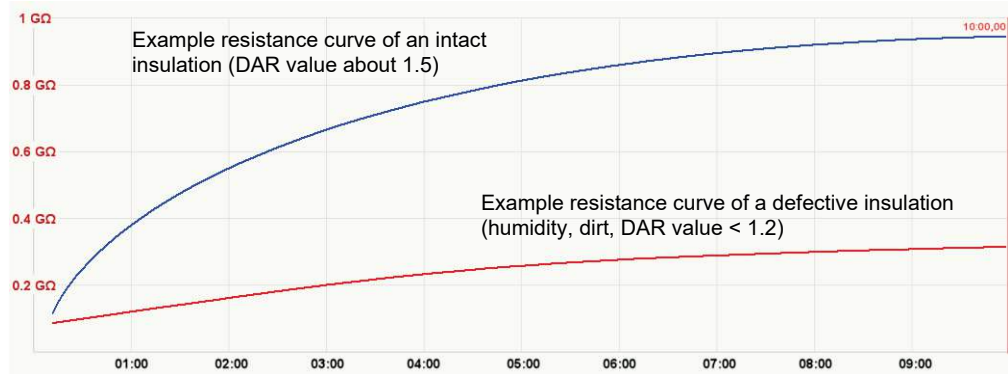

The following table provides generally accepted guidelines values that can be used to evaluate the measurement:



PI value	DAR value	Condition of insulation
<1	<1	poor
1 to 2	1 to 1.3	questionable
2 to 4	1.3 to 1.6	Good
>4	>1.6	excellent

A comparison with intact cables of identical construction or with previous measurements should also be considered.

To do so, previous measurements from “History” database (see page 45) can be accessed and the resistance curves compared. By selecting the menu option , the determined DAR and/or PI coefficients can also be displayed for comparison.





**6.5 Cable testing - **



*Selecting the operating mode* The operating modes for cable testing are usually grouped not directly in the main menu but rather in the sub-menu .

Menu item	Operating mode
	Cable testing with VLF cosine rectangular voltage using the optional VLF CR-54 kV or VLF CR-70 kV test attachment.
	Cable testing with negative DC voltage (using the internal voltage source)

*Setting the measurement parameters* The phases and the voltage range are automatically queried when entering the operating mode, however – like all other settings – they can be adjusted until the actual start of the test.

Depending how the test van is equipped and the selected operating mode, the following measurement parameters can be set:

Button / Menu item	Description
	The phase selection must be carried out in accordance with the actual type of connection. It is also possible to test several phases at once to save time. To this end, the phase selection menu permits the selection of more than one option. The phase selection menu must then be closed using  .
	The test duration is shown in minutes. On expiry of the test duration, the high voltage is switched off automatically.
	Voltage range for the upcoming test. After starting the test, the actual test voltage can only be set within this range.
	<u>Can only be set for testing with the internal test voltage source</u> Setting of the slew rate in kV/s. After confirmation of the test voltage, the test object is charged continually at the set slew rate until it reaches the set value. The voltage increase can be paused and resumed. In the <b>Manual</b> setting, the increase of the test voltage is regulated manually with the rotary control and the test object is charged to the set value as quickly as possible without requiring confirmation. The test voltage then remains at this level until the set value is again manually increased or decreased.

Button / Menu item	Description
	<p><u>Can only be set for testing with the internal test voltage source</u></p> <p>Limitation of maximum current (0.1 mA ... 300 mA)</p> <p>The test voltage source automatically suspends the test if this value is exceeded. A message shows the cause of tripping and the maximum attained voltage.</p>
	<p><u>Can only be set for testing with the internal test voltage source</u></p> <p>Current monitoring during charging phase on/off</p> <p>This menu item can be used to determine whether the test is automatically stopped, if the specified maximum current is exceeded during the charging phase. If this option is disabled, the maximum current is monitored during the plateau phase only. To ensure fast switch-off and avoid unnecessary stress to the device under test, it is recommended to enable this option for tests with test voltages &lt;10 kV.</p>

*Notes on selecting the test voltage and test time* The requirements for a meaningful cable test are found in the harmonization documents HD 620 S1:1996 and HD 621 S1:1996 and often in company-internal testing guidelines as well.

The following table provides a selection of proven test parameters for various applications:

Application	Test voltage	Test duration in minutes
VLF test (initial use)	3U <sub>0</sub>	15 to 60
VLF test (on aged cables)	1.7 ... 3U <sub>0</sub>	60
DC test (on PILC cables)	4 ... 8U <sub>0</sub>	15 ... 30

**Starting the test** Once all the relevant parameters for the test as well as the phase(s) have been set, the test can be started using the menu item. Following this the high voltage must be authorized using the “HV ON” button and the test voltage set.

As soon as high voltage is enabled, the “HV OFF” button lights up red signaling “high voltage at the HV output”.

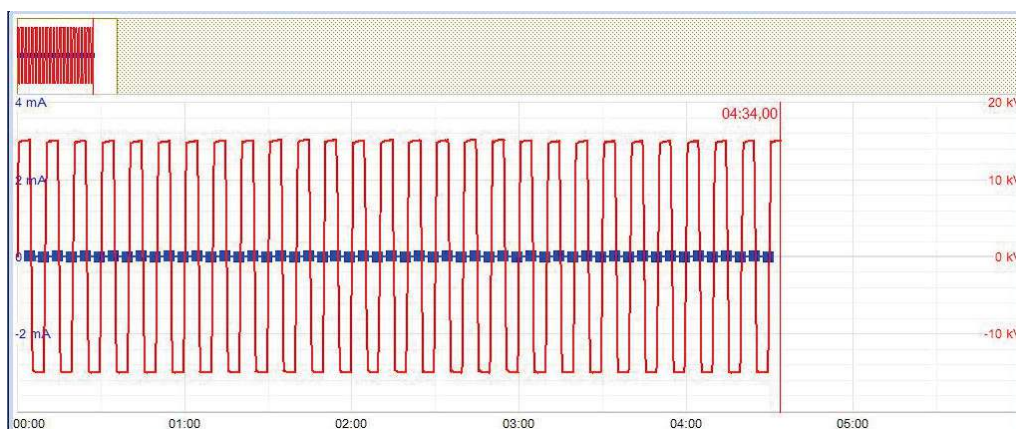

The dialogue for setting the voltage closes automatically after a few seconds for safety reasons but it can be accessed again using the menu item.

**Performing the test** The voltage curve can be followed on the screen during the test. In DC, and cosine rectangular mode leakage current measurement is carried out too.



The test duration can be adjusted retrospectively even while the test is ongoing using the menu item or reset using the menu item.

Alongside the current and voltage values, some other relevant parameters and measurement values are shown at the bottom edge of the screen depending on the operating mode and the type of test voltage source.

Symbol	Description
	Remaining test duration
	Set test duration
	The load capacitance determined at the start of the test

*Finishing the test* If a test time was defined, the high voltage is automatically switched off at the end of this time. The measurement can be manually deactivated at any time via the “HV OFF” button or the **HV Off** menu item.

If a voltage breakdown occurs in the test object during the test duration, the test is also interrupted. In which event, the test does not qualify as having been passed. The user is informed about the breakdown voltage and – for multi-phase testing – the affected phase.

Irrespective of whether the high voltage is switched off automatically or manually, the HV output is discharged and earthed. The test data logged up to the switch-off are recorded in the history database (see page 45).

### 6.6 Pulse reflection measurement (TDR) -

*Introduction* Low-resistance cable faults can be localized using the tried-and-tested and widely-used pulse reflection measurements. This method is based on the radar principle and makes use of the fact that any sudden deviations in the characteristic impedance of a cable reflect part of the energy transmitted into the cable. The degree of reflection is dependent on the magnitude of the deviation in the characteristic impedance, the number of reflections, the cable length and the distance to the fault position.

The recorded curve shows any deviation in the cable's characteristic impedance. Naturally, this means that not only fault positions, but also other changes in resistance such as, e.g. in joints are also recorded. These recordings can indeed also represent an additional orientation aid for accurate pinpointing of the fault position.







The special IFL operating mode (Intermittent Fault Locating) can be used to localise sporadically (time-variant) occurring low-resistance cable faults (caused, e.g. through traffic vibrations).

To this end, the individual curves in this operating mode are not continuously updated, but rather they form an enveloping curve from all the recorded measurements. In this way, any changes that occur (e.g. temporary fault triggering) during continuous measurements are rendered visible for the user.



*Selecting the operating mode and phases*

The menu with the TDR operating modes can be accessed directly from the main menu using the menu item  and, depending on the equipment in the test van, it can include the following menu items:

Menu item	Operating mode
	Normal pulse reflection measurement via the HV connection cable
	Normal pulse reflection measurement via the optional LV connection cable
	IFL measurement via the HV connection cable
	IFL measurement via the optional LV connection cable

Directly upon entering the operating mode, the phases to be tested are queried. The phases must then be configured according to the actual connection situation.

When you select a single phase (for example **L1 - N**), a reflection measurement is performed between the phase and the cable sheath. Here, not only the sought error is visible, the connection sleeve and tee joints are as well. They can often be used for orientation for fault location. For comparison purposes, additional individual phases can be activated for the measurement as desired.

Once one of the type “L - L” options (for example **L1 - L2**) has been selected, a differential measurement is performed between the two phases. In this mode the reflections of both inputs are combined to form a single curve. However, the reflections received at the second input have their polarity reversed through a differential transformed. Consequently, the differential curve generated here then shows genuine differences only. Faults of identical magnitude, all-core breaks or cable inhomogeneities (such as joints) will not be visible because a difference does not exist.

After selection of the desired options, the phase selection menu must be closed using . If necessary, the phase selection can be opened later and modified.

**Averaging** In the operating modes  $\frac{F}{HVC}$  and  $\frac{F}{LVC}$  the averaging function can be activated or deactivated using the menu item . When averaging is active, the curve shown on the display presents the average of all previously recorded measurements. A maximum of 256 measurements are taken into consideration here. After reaching this figure, the recording stops automatically.

The number of measurements taken into consideration for the averaging function is shown at the bottom area of the display and it is continuously updated.

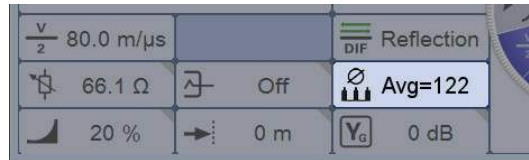

**Performing measurements** After selecting the operating mode and the phases, proceed as follows to perform a pulse reflection measurement:

Step	Action
1	Use the Teleflex menu (see page 61) to make suitable settings for the diffusion speed, pulse width, pulse amplitude and filter and, if necessary, activate the averaging function (see above).
2	Start the measurement using the menu item .
3	Enable the voltage conditioning using the “HV ON” button. <b>Result:</b> Continuous measuring pulses are coupled into the phases involved in the measurement. Depending on the operating mode the recording curves are either continuously updated or combined to form an enveloping curve.
5	Examine the recorded reflectogram for deviations (see page 60) and, if necessary, use the available functions (see page 61) to improve the accuracy and display of the curve. In IFL mode, you may try to trigger an intermittent fault by appropriate means.
6	Stop the measurement using the menu item <b>Result:</b> The measurement is stopped and the current curve frozen. When necessary, the measurement can be continued using menu item .

## 6.7 Pre-location of high-resistance cable faults -

To perform accurate pinpointing of the cable fault in as small a segment of the cable route as possible, a thorough prelocation procedure should be conducted beforehand. This achieves a significantly shorter total location time while also protecting the cables.

High-resistance cable faults reflect the low voltage pulses of a normal pulse reflection measurement either inadequately or not at all, so that the fault location cannot be identified using the recorded reflectogram. In this event, several other pre-location methods have established themselves, each of which combines a high-voltage process with the pulse reflection method. All these methods force arcing at the fault location through a “breakdown” caused by a sudden discharge of a charged capacitor or by charging the cable. Because the fault assumes the state of a low-resistance cable fault for a short time, its position can be measured beyond this period with a pulse reflection measurement.

The fault position can also be pre-located with sufficient accuracy using the oscillating travelling wave between the fault location and the measurement system that is triggered after the voltage breakdown.

In some pre-location modes, the  menu item can be used to specify the way the fault breakdown is caused. The following options can be selected:

- Surging** The breakdown is forced through abrupt capacitive discharge of the surge capacitor.
- Charging** With the surge switch closed, the surge capacitor and the connected cable itself are charged to the required breakdown voltage. The available surge capacity is thereby increased by the cable capacity, which can be very useful for particularly slow cables.

### 6.7.1 Arc reflection measurement (ARM) -

*Introduction* The ARM method is suited for the pre-location of high-resistance cable faults on power cables with a total length of up to 10 km. For faults with low ignition voltage (<50 kV), pre-location should be started with this method.

When locating the fault position a reflectogram is taken first under normal conditions (reference trace). The charged surge capacitor is then discharged suddenly into the cable and 15 reflection measurements are carried out in the static arc caused by faulty ignition. The user can then select the most suitable fault pattern from the 15 recorded patterns.

The direct comparison of reference and fault pattern usually makes possible immediate, clear identification of the fault location, because, due to the reflection at the burning arc, the fault pattern displays a significantly negative reflection at the fault location compared to the functional image.

*Delay between TDR measuring pulses*

Before recording a fault trace, the user can manually configure the delay between two successive pulses using the menu item . This type of delay however, should not be confused with the trigger delay time (see next page), which only delays the first pulse.

In principle it is advisable to record the first series of fault traces with a default delay of 256  $\mu$ s.

If required the delay can be varied to suit between 0  $\mu$ s and 3.84 ms and a renewed faulty ignition undertaken.

For a setting of 0  $\mu$ s the pulses are triggered as quickly as possible one after the other.

The effect of a delay adjustment is best illustrated in the current curve following a voltage flash-over:

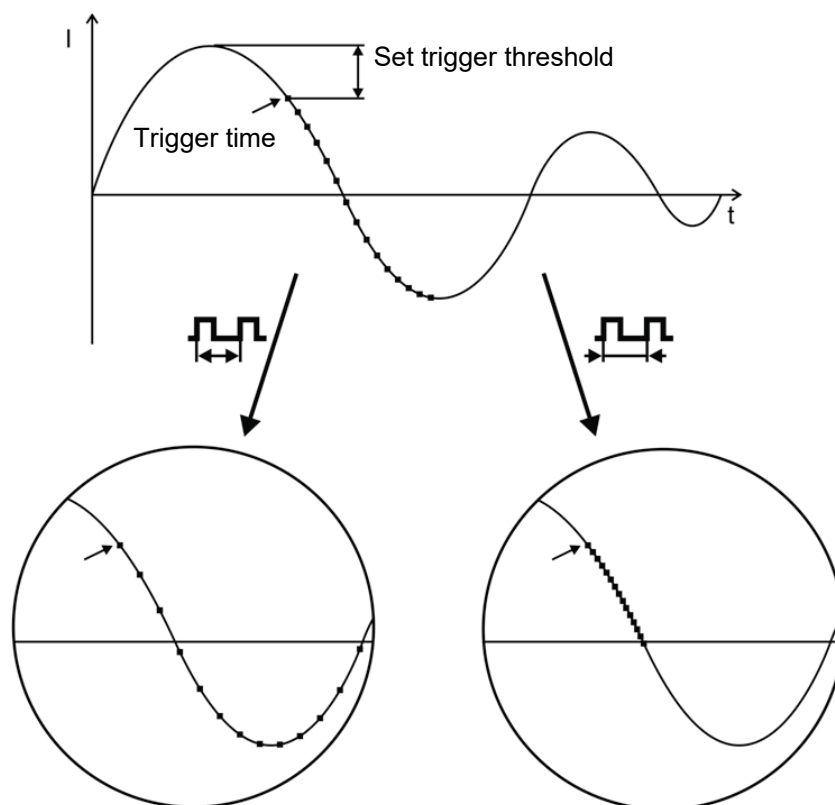

■ Triggering a measuring pulse

As can be clearly seen in the figure, an increase in the delay enables a “wider” period to be mapped, in which the arc - under certain circumstances - is extinguished before igniting again.

**Adjusting trigger delay time** A user issued with Administration rights (see page 54) can use the menu item  to adjust the delay time between the received trigger signal (configured trigger threshold exceeded) and the actual start of the TDR measurement.

This is intended to give the ignition process at the fault position sufficient time to form a stable arc.











Basically, the delay time is set to an ideal setting at the factory for the system configuration and it should only be adjusted in exceptional cases (in very special measurement layouts) and this should be conducted by experienced users only.

Any improper adjustment to the delay time poses the following risks:

- **Delay time too short:** The arc is unstable and the reflectogram is not representative or it is faulty.
- **Delay time too long:** As the delay time increases the risk of conducting a measurement in the decay curve's zero crossing increases. The ignition procedures repeated now can falsify the reflectogram. If the delay time is excessively high, there is also a risk that the arc may already be completely extinguished.

### 6.7.1.1 ARM measurement up to 12 kV (with Surge Unit 3/6/12 kV)

**Procedure** Proceed as follows to perform a fault prelocation:

Step	Action
1	When in the submenu  activate the menu item  .
2	Select the defective phase in the phase selection menu and close the menu using  .
3	Set the voltage range to 12 kV.
4	Use the Teleflex menu (see page 61) to make suitable settings for the propagation velocity, pulse width, pulse amplitude and the filter.
5	Start recording the reference trace using the menu item  .
6	Enable the high voltage using the "HV ON" button. <b>Result:</b> Following a brief calibration procedure the reference trace is shown on the display.
7	Check whether the recorded curve and, in particular, the marked end of the cable match the expected result. If necessary, use the available functions (see page 61) to improve the accuracy and the display of the reference trace. Stop the measurement via the menu item  , as soon as you are satisfied.
8	Prepare the system for fault trace recording using the menu item  .
9	Using the large range selector  on the Surge Unit 3/6/12 kV, set the required voltage range and turn the rotary knobs to set the surge rate  and the surge voltage  to the left limit stop.
10	Switch on the Surge Unit 3/6/12 kV via the on/off switch  and activate the high voltage standby via the <b>HV</b> button  .





Step	Action
11	<p>Taking the required fault ignition voltage into consideration, set the surge voltage on the Surge Unit 3/6/12 kV using the rotary knob <b>11</b> and then trigger a single shot using the  menu item on the Teleflex VX.</p> <p><b>Result:</b> If a voltage flash-over occurs at the fault position, a second trace (fault trace) is shown on the display.</p> <p>If triggering failed to occur and a fault trace was accordingly not recorded, it may be necessary to adjust the trigger threshold (on the Teleflex VX) or the surge voltage (on the Surge Unit 3/6/12 kV) before triggering a further surge.</p>
12	<p>Turn the rotary encoder to select one of the 15 recorded curves and confirm your selection by pressing it briefly. The selected curve can be changed using the menu item  up until the next measurement is started or the operating mode is changed.</p> <p><b>Result:</b> The red marking is automatically positioned at the location identified as the fault position (at which the two curves diverge).</p> 
13	<p>If necessary, use the available functions (see page 61) to optimize the curve display (filter, amplification) and re-adjust the marked fault position. Then read off the fault distance.</p>
14	<p>Switch off the high voltage using the menu item <b>HV OFF</b>.</p>

## 6.7.1.2 ARM measurement up to 50 kV (double surge unit)

**Introduction** In the double surge procedure, the fault is ignited using high voltage (25 / 50 kV surge circuit). Due to the ionisation phase that occurs during the ignition, the available time would however be insufficient to obtain a stable and meaningful fault trace. Consequently, as soon as a sufficiently high and stable current flows, the surge unit 3/6/12 kV is discharged into the static arc. In this manner, it is stabilised, and the burn duration clearly extended, which then makes a reliable measurement possible.

	<p><b>Wear ear protection</b></p> <p>Surge operation can cause high and sudden noise levels. It is strongly recommended to wear hearing protection during surge operation. Keep in mind that this will limit the operator's awareness for ambient dangers.</p>
---	--

**Procedure** Proceed as follows to perform a fault prelocation:

Step	Action
1	When in the submenu <b>PRE</b> activate the menu item  .
2	Select the defective phase in the phase selection menu and close the menu using  .
3	Set the voltage range to 50 kV.
4	Use the Teleflex menu (see page 61) to make suitable settings for the propagation velocity, pulse width, pulse amplitude and the filter.
5	Start recording the reference trace using the menu item  .
6	Enable the high voltage using the "HV ON" button. <b>Result:</b> Following a brief calibration procedure the reference trace is shown on the display.
7	Check whether the recorded curve and, in particular, the marked end of the cable match the expected result. If necessary, use the available functions (see page 61) to improve the accuracy and the display of the reference trace. Stop the measurement via the menu item  , as soon as you are satisfied.
8	Prepare the system for fault trace recording using the menu item <b>REF FAU</b> .
9	Taking the required fault ignition voltage into consideration, set the surge voltage.
10	Using the large range selector <b>10</b> on the Surge Unit 3/6/12 kV, set the required voltage range and turn the rotary knobs to set the surge rate <b>13</b> and the surge voltage <b>11</b> to the left limit stop.
11	Switch on the Surge Unit 3/6/12 kV via the on/off switch <b>14</b> and activate the high voltage standby via the <b>HV</b> button <b>15</b> .
12	Select the voltage setting <b>3-6-12</b> on the surge unit 3/6/12 kV using the rotary knob <b>11</b> and then trigger a single shot using the  menu item on the Teleflex VX.

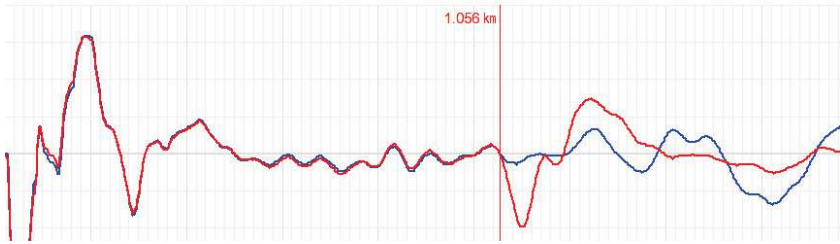
Step	Action
	<p><b>Result:</b> If a voltage flash-over occurs at the fault position, a second trace (fault trace) is shown on the display.</p> <p>If triggering failed to occur and a fault trace was accordingly not recorded, it may be necessary to adjust the trigger threshold or the surge voltage on the Teleflex VX before triggering a further surge.</p>
<p><b>13</b></p>	<p>Turn the rotary encoder to select one of the 15 recorded curves and confirm your selection by pressing it briefly. The selected curve can be changed using the menu item  up until the next measurement is started or the operating mode is changed.</p> <p><b>Result:</b> The red marking is automatically positioned at the location identified as the fault position (at which the two curves diverge).</p> 
<p><b>14</b></p>	<p>If necessary, use the available functions (see page 61) to optimize the curve display (filter, amplification) and re-adjust the marked fault position. Then read off the fault distance.</p>
<p><b>15</b></p>	<p>Switch off the high voltage using the menu item <b>HV OFF</b>.</p>





## 6.7.2 Voltage decoupling (DECAY) -



**Introduction** The decay method is used to pre-locate high-resistance cable faults using a high fault ignition voltage (<110 kV) in rechargeable cables.

To this end, the cable is charged with a DC voltage until the voltage exceeds the fault's breakdown voltage. The energy stored in the cable capacitance discharges through the fault and generates a travelling wave, which is recorded and displayed by the system as an attenuated oscillation. The period of this oscillation can be used along with the following formula to determine the actual fault distance:

$$\text{Fault distance} = \frac{\text{Full period distance}}{2} - \text{Length of HV connection cable}$$

**Procedure** Proceed as follows to pre-locate a cable fault using the DECAY method:

Step	Action
1	When in the submenu  activate the menu item  .
2	Select the defective phase in the phase selection menu and close the menu using  .
3	Set the voltage range, taking the required fault ignition voltage into consideration.
4	Use menu item $\frac{V}{2}$ or <b>NVP</b> to set the propagation velocity and then use menu item  to set the measuring range to roughly five to ten times the complete length of the cable.
5	Start the measurement using the menu item  .
6	Enable the high voltage using the "HV ON" button.

Step	Action
7	<p>Increase the voltage to the desired test voltage using the rotary encoder and confirm the value by pushing in the rotary encoder.</p> <p>The dialogue for setting the voltage closes automatically after a few seconds for safety reasons but it can be accessed again using the menu item <b>U<sub>NOM</sub></b></p> <p><b>Result:</b> The test object is charged to the set voltage. Once the fault breaks down, an attenuated and oscillating voltage curve is shown in the display and the voltage conditioning is interrupted.</p>  <p>The software automatically attempts to calibrate a period of the oscillation and to set corresponding markings.</p>
8	<p>Switch off the high voltage using the menu item <b>HV OFF</b>.</p>
9	<p>If the recorded decay curve is superimposed to an excessive degree by interference signals, it uses the available filter settings (see page 61) to smooth the characteristic of the curve. Amplitudes that are too high can be counteracted by reducing the amplification (see page 61).</p> <p>Each time an adjustment is made, you must repeat the procedure from <b>Step 5</b>.</p>
10	<p>If the automatically set markings do not enclose a period exactly, you can use the function <b>→</b> to correct their positions.</p> <p>Half the distance of one period is shown directly next to the cursor and in the bottom left corner of the display.</p> 
11	<p>Subtract the length of the connection cable from this value and the internal wiring of the test van. This equates to a total of approx. 65 metres in the case of a standard 50-metre cable drum.</p> <p>The calculated value roughly corresponds to the distance between the connection point and the fault. For technical reasons, this method has a slightly higher tolerance than, for example, pre-location using the ARM method.</p>





## 6.7.3 Current decoupling (ICE) -

**Introduction** Prelocation using current decoupling has established itself, particularly regarding faults in the lower kOhm range and for extremely large fault distances, in which the ARM- method often fails to achieve any results.



As with the ARM method, an abrupt discharge of the surge capacitor triggers a breakdown in the fault. Consequently, an attenuated transient wave moves back and forth between the fault location and the measurement system. Inductively decoupling the current causes the display of an oscillation, which has a period equivalent to a single fault distance. However, the length of the pre-measuring cable still needs to be deducted from this distance.

### 6.7.3.1 ICE prelocation up to 12 kV (with Surge Unit 3/6/12 kV)

**Procedure** Proceed as follows to pre-locate a cable fault using the ICE method:

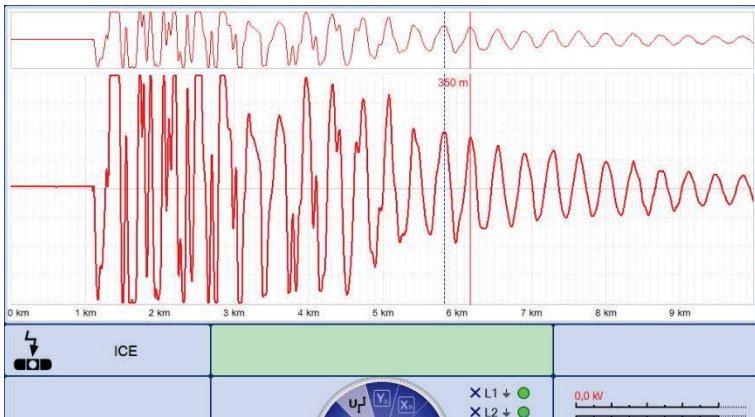

Step	Action
1	When in the submenu <b>PRE</b> activate the menu item  .
2	Select the defective phase in the phase selection menu and close the menu using  .
3	Set the voltage range to 12 kV.
4	Use menu item $\frac{V}{2}$ or <b>NVP</b> to set the propagation velocity and then use menu item <b>X<sub>R</sub></b> to set the measuring range to roughly five to ten times the complete length of the cable.
5	Use the menu item  to select whether the fault breakdown should be forced by charging the cable or by triggering a surge discharge (see page 78).
6	Start the measurement using the menu item  .
7	Enable the high voltage using the "HV ON" button.
8	Using the large range selector <b>10</b> on the Surge Unit 3/6/12 kV, set the required voltage range and turn the rotary knobs to set the surge rate <b>13</b> and the surge voltage <b>11</b> to the left limit stop.
9	Switch on the Surge Unit 3/6/12 kV via the on/off switch <b>14</b> and activate the high voltage standby via the <b>HV</b> button <b>15</b> .



Step	Action
10	<p>Taking the required fault ignition voltage into consideration, set the surge voltage on the Surge Unit 3/6/12 kV using the rotary knob <b>11</b> and then trigger a single shot using the  menu item on the Teleflex VX.</p> <p><b>Result:</b> If a voltage flash-over occurs at the fault position, the display shows an attenuated and oscillating current curve.</p>  <p>The software automatically attempts to calibrate a period of the oscillation and to set corresponding markings.</p> <p>If triggering failed to occur, and therefore a fault trace was not made, it may then be necessary to adjust the trigger threshold or the surge voltage before triggering a further surge.</p>
11	Switch off the high voltage using the menu item <b>HV OFF</b> .
12	<p>If the recorded decay curve is superimposed to an excessive degree by interference signals, it uses the available filter settings (see page 61) to smooth the characteristic of the curve.</p> <p>Amplitudes that are too high can be counteracted by reducing the amplification (see page 61).</p> <p>Each time an adjustment is made, you must repeat the procedure from <b>Step 6</b>.</p>

Step	Action
13	<p>If the automatically set markings do not enclose a period exactly, you can use the function  to correct their positions.</p> <p>The distance of one period is shown directly next to the cursor and in the bottom left corner of the display.</p> 
14	<p>Subtract the length of the connection cable from this value and the internal wiring of the test van. This equates to a total of approx. 65 metres in the case of a standard 50-metre cable drum.</p> <p>The calculated value roughly corresponds to the distance between the connection point and the fault.</p> <p>For technical reasons, this method has a slightly higher tolerance than, for example, pre-location using the ARM method. With the ICE methods, often 5 ... 10% larger distances are measured, which is why measurement technicians should first walk toward the test van when pinpointing the pre-located fault position.</p>

### 6.7.3.2 ICE prelocation up to 50 kV or 80 / 100 kV (optional)

*Procedure* Proceed as follows to perform a fault prelocation:

Step	Action
1	When in the submenu <b>PRE</b> activate the menu item  .
2	<p>Select the defective phase in the phase selection menu and close the menu using .</p> <p>For operation in 80/100 kV mode, refer to the special notes on electrical connection (see page 26) and phase selection (see page 44).</p>
3	Depending on the fault ignition voltage set the voltage range to 25 kV or 50 kV (in 80/100 kV mode, the voltage range is automatically set to 80 or 100 kV).
4	Use menu item $\frac{v}{2}$ or <b>NVP</b> to set the propagation velocity and then use menu item <b>X<sub>R</sub></b> to set the measuring range to roughly five to ten times the complete length of the cable.
5	Use the menu item  to select whether the fault breakdown should be forced by charging the cable or by triggering a surge discharge (see page 78).

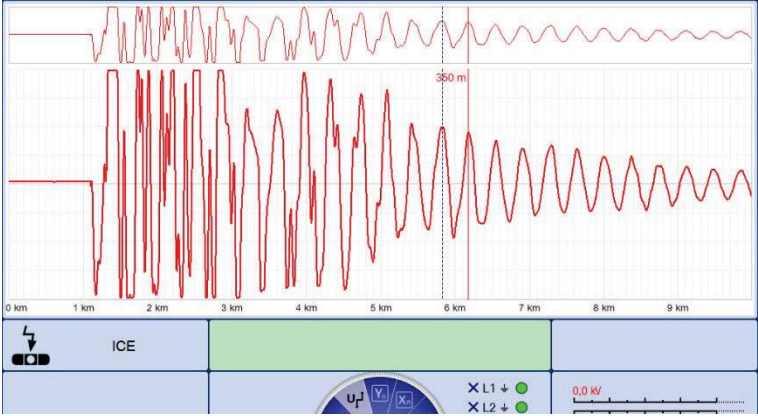
Step	Action
6	Start the measurement using the menu item  .
7	Enable the high voltage using the “HV ON” button.
8	<p>Set the voltage, taking the required fault ignition voltage into consideration.</p> <p>If the fault will be caused by surge discharge to breakdown, this needs to be initiated using the menu item  once the surge capacitor has been charged to the set voltage.</p> <p>If instead the cable should be charged to the fault breakdown, the system starts immediately with voltage conditioning.</p>
	<p><b>Result:</b> If a voltage flash-over occurs at the fault position, the display shows an attenuated and oscillating current curve.</p>  <p>The software automatically attempts to calibrate a period of the oscillation and to set corresponding markings.</p> <p>If triggering failed to occur, and therefore a fault trace was not made, it may then be necessary to adjust the trigger threshold or the surge voltage before triggering a further surge.</p>
9	Switch off the high voltage using the menu item <b>HV OFF</b> .
10	<p>If the recorded decay curve is superimposed to an excessive degree by interference signals, it uses the available filter settings (see page 61) to smooth the characteristic of the curve.</p> <p>Amplitudes that are too high can be counteracted by reducing the amplification (see page 61).</p> <p>Each time an adjustment is made, you must repeat the procedure from <b>Step 6</b>.</p>

Step	Action
11	<p>If the automatically set markings do not enclose a period exactly, you can use the function <math>\rightarrow</math> to correct their positions.</p> <p>The distance of one period is shown directly next to the cursor and in the bottom left corner of the display.</p> 
12	<p>Subtract the length of the connection cable from this value and the internal wiring of the test van. This equates to a total of approx. 65 metres in the case of a standard 50-metre cable drum.</p> <p>The calculated value roughly corresponds to the distance between the connection point and the fault.</p> <p>For technical reasons, this method has a slightly higher tolerance than, for example, pre-location using the ARM method. With the ICE methods, often 5 ... 10% larger distances are measured, which is why measurement technicians should first walk toward the test van when pinpointing the pre-located fault position.</p>

### 6.7.4 Three-phase current decoupling (optional) -

*Introduction* Three-phase current decoupling is used to locate high-resistance and sporadic cable faults in **branched cables networks**. The ignition voltage of the fault may not exceed 50 kV.

From the different known methods, the differential comparison method has proven itself in particular for pre-location of faults in the branched low voltage network, which is why the description in this section is based mainly on this method.

With the differential comparison method, in addition to the defective phase, an intact phase must also be connected and activated. For comparison purposes, after a measurement with open ends, additional measurements need to be performed in which the cable ends (and later also the ends of the branches, if necessary) must be bridged.

*Special features for the phase selection* The system is equipped with various current couplers, which can catch the current from one or more phases, depending on the connection configuration.

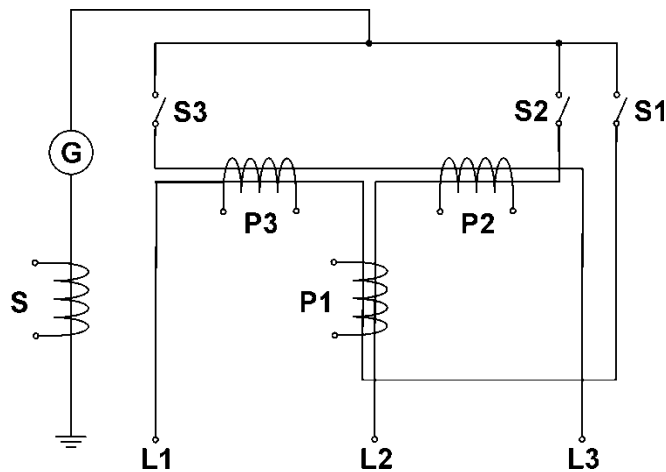

Accordingly, depending on the connected phases, the following signals are caught at the various couplers:

Connected phases	Additive coupler S	Differential coupler		
		P1	P2	P3
L1	L1	L1	-	L1
L2	L2	L2	L2	-
L3	L3	-	L3	L3
L1, L2	L1+L2	L1-L2	L2	-L1
L1, L3	L1+L3	L1	-L3	L3-L1
L2, L3	L2+L3	-L2	L2-L3	L3

In the phase selection menu, in addition to the connected phase, the current coupler to be used must also be selected. This ensures that the desired sum or differential signal is displayed as reflectogram.

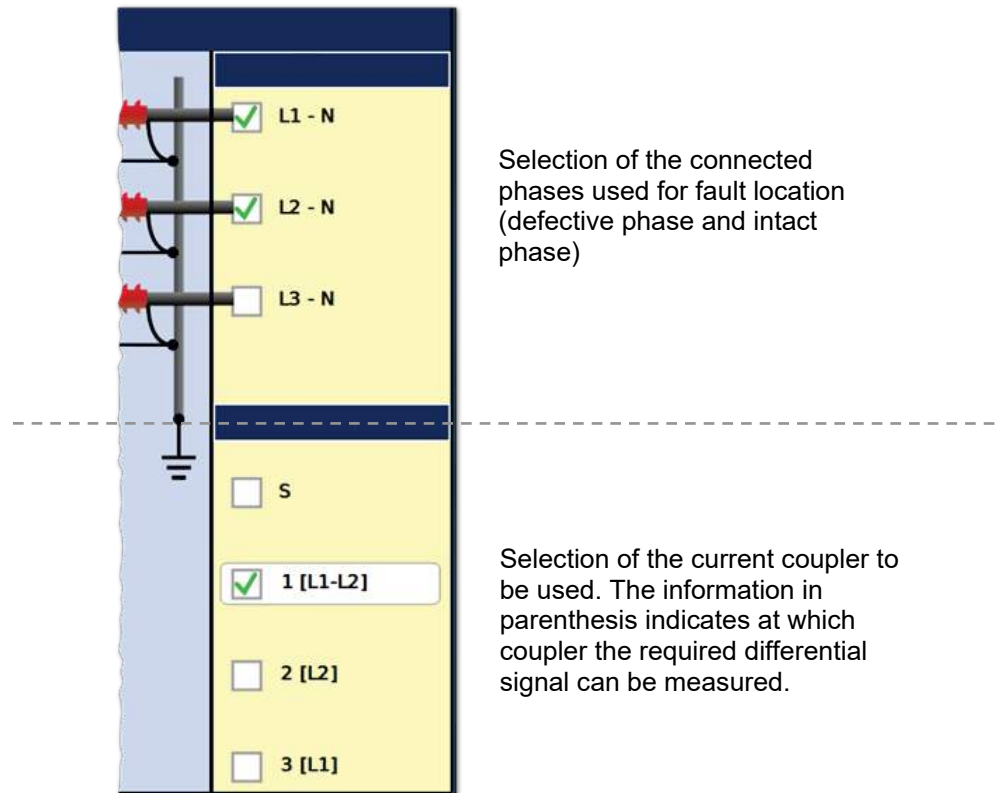

For example, if a fault in phase L1 needs to be localized using the differential comparison method and L2 will serve as the intact phase, the options **L1** and **L2** must first be activated. The differential coupler P1 (option **1 [L1-L2]**) must then be activated, over which the differential signal between L1-L2 is decoupled.

*Procedure* Proceed as follows to pre-locate a cable fault using the differential comparison method:

Step	Action
1	When in the submenu <b>PRE</b> activate the menu item
2	In the phase selection menu, select the two phases involved in the measurement and the current coupler over which the differential signal of these two phases can be decoupled. Please observe the instructions on previous pages. Then close the menu using
3	Carry out an ICE measurement in a suitable voltage range (see page 86).
4	Bridge the defective line and the intact line at the far end of the cable.
5	Prepare the software for recording a second reflectogram using the menu item <b>TR1</b> / <b>TR2</b> .
6	Carry out another ICE measurement (see page 86).  <b>Result:</b> A second reflectogram is shown that differs from the first diagram in that the reflection directed from the fault location to the end of the cable now runs back to the start of the cable via the bridge and the intact line, and when it passes through the current coupler, an additional reflection is caused.
7	Switch off the high voltage using the menu item <b>HV OFF</b> .
8	Based on the differential comparison method, determine the fault distance. If the calculation indicates that the fault location is in a branch, another measurement must be performed with the ends of the corresponding branch bridged.









## 6.7.5 ARM burning with the 15 kV burn down unit (optional) -

**Introduction** In ARM burning a continuous arc reflection measurement takes place during the burning process that sets in after the fault breakdown. This enables any changes in the fault caused by the burning process to be monitored on the screen.

As with the ARM method, the reference trace and the fault pattern are compared with each other, and the fault distance can be read off directly.

The advantage of this method compared with conventional burning is the controlled procedure which restricts the actual burning to the shortest necessary time and by doing so preserves the cable's service life.

**Procedure** Proceed as follows to pre-locate a cable fault using the ARM burning method:

Step	Action
1	When in the submenu <b>PRE</b> activate the menu item 
2	Select the defective phase in the phase selection menu and close the menu using  .
3	Use the Teleflex menu (see page 61) to make suitable settings for the propagation velocity, pulse width, pulse amplitude and the filter.
4	Start recording the reference trace using the menu item  <b>Result:</b> Following a brief calibration procedure the reference trace is shown on the display.
5	Check whether the recorded curve and, in particular the marked end of the cable, match the expected result. If necessary, use the available functions (see page 61) to improve the accuracy and the display of the reference trace then repeat the recording using the menu item  .
6	The menu item  can be used to activate or deactivate an automatic switch-off. If automatic switch-off is activated, the measurement is automatically stopped as soon as the fault position becomes clearly apparent during the burning procedure when comparing reference and fault traces. Otherwise, the measurement must be manually stopped.
7	Prepare the system for fault trace recording using the menu item  .
8	Put the 15 kV burn unit into operation.   For information on operating the 15 kV burn unit, refer to the corresponding operating manual.
9	Initiate the burning process using the burn down instrument and observe the resulting fault conversion during the burning process on the screen of the Teleflex VX. Stop the measurement using the menu item  , as soon as the fault position becomes clearly apparent through the comparison of reference and fault traces. In this case, when the automatic switch-off is activated, the measurement is automatically stopped.





Step	Action
10	If necessary, use the available functions (see page 61) to optimise the curve display (filter, amplification) and re-adjust the marked fault position. Then read off the fault distance.
11	Switch off the high voltage using the menu item <b>HV OFF</b> .

## 6.8 Burning

*Purpose* What is known as “burning” enables ongoing conversion of high-impedance faults into low-impedance shunts right up to saturated short-circuits. Thanks to steady improvement in prelocation methods, this material-stressing method must be used only very rarely with difficult faults, such as with intermittent cable faults and moist cable faults.





### 6.8.1 Burning up to 110 kV (with internal voltage source)

*Procedure* Proceed as follows to perform a fault conversion:

Step	Action
1	When in the submenu  activate the menu item  .
2	Select the defective phase in the phase selection menu and close the menu using  .
3	Set the desired voltage range.
4	If desired, limit the maximum burning time via the menu item  .
5	Start the operating mode using the menu item  .
6	Enable the high voltage using the “HV ON” button.
7	<p>Slowly increase the voltage until it reaches fault ignition voltage using the rotary encoder. The voltage will be ramped up to the set target value immediately without prior confirmation!</p> <p>The dialogue for setting the voltage closes automatically after a few seconds for safety reasons but it can be accessed again using the <b>U</b> menu item.</p> <p><b>Result:</b> The high voltage source starts charging the cable up to the set voltage. The voltage and current curves are shown on the display.</p> <p>As soon as the fault is ignited, the voltage drops abruptly while the burning current rises sharply.</p> <p>A few minutes are usually enough to convert the fault resistance so that it may be localised using an HV prelocation method.</p>
8	As soon as you want to end the firing process Switch off the high voltage using the menu item <b>HV OFF</b> .



### 6.8.2 Burning with the 15 kV burn unit (optional)

*Procedure* Proceed as follows to perform a fault conversion:

Step	Action
1	When in the submenu  activate the menu item  .
2	Select the defective phase in the phase selection menu and close the menu using  .
3	Set the voltage range to <b>15 kV</b> .
4	Start the operating mode via the  menu item.
5	Enable the high voltage using the "HV ON" button.
6	Start the 15 kV burn unit and try to convert the fault resistance. <hr/> <div style="display: flex; align-items: center;">                      For information on operating the 15 kV burn unit, refer to the corresponding operating manual.                 </div> <hr/>

## 6.9 Fault pinpointing







**Purpose** The aim of every cable fault pinpointing is the precise location of the fault position to avoid unnecessary excavation works.



**Selecting the operating mode** The two surge operating modes are grouped in the sub-menu . Using the menu item , pure surge mode can be started, in which no curves are recorded or displayed.

For paper-insulated cables in particular, however, it can be helpful to be able to directly track any changes in the ignition behaviour of the fault during surging. In this case, the operating mode  should be selected, which combines traditional surging with a pre-location method (current decoupling). Here, the oscillating curve of the inductively decoupled current is shown in the display during surge operation and refreshed with each surge. If a change occurs, the refresh can be stopped manually at any time and the current curve examined more closely. Surge mode continues unchanged.

### 6.9.1 Surge pinpointing up to 12 kV (with surge unit 3/6/12 kV)

**Procedure** Proceed as follows to perform fault pinpointing:











Step	Action
1	When in the submenu  activate the menu item  or  .
2	Select the defective phase in the phase selection menu and close the menu using  .
3	Set the voltage range to 12 kV.
4	Using the large range selector <b>10</b> on the Surge Unit 3/6/12 kV, set the required voltage range and turn the rotary knobs to set the surge rate <b>13</b> and the surge voltage <b>11</b> to the left limit stop. In order to achieve the highest possible surge energy, it is recommended to select the smallest voltage range required to ignite the fault!
5	Use the menu item  to select whether the surge discharges are to be decoupled automatically or manually. With automatic surge decoupling, the desired distance between two surges (surge rate) can be set down to the second using the menu item  .
6	Start the operating mode via the  menu item.
7	Enable the high voltage using the “HV ON” button.
8	Switch on the Surge Unit 3/6/12 kV via the on/off switch <b>14</b> and activate the high voltage standby via the <b>HV</b> button <b>15</b> .
9	Set the required surge voltage on the Surge Unit 3/6/12 kV using the rotary knob <b>11</b> .

Step	Action
10	<p>Start surge operation via the  menu item on the Teleflex VX.</p> <p><b>Result:</b> In time with the set surge rate, the system couples surge pulses into the test object that result in flash overs at the fault position.</p> <p>In manual surge mode, each surge discharge must be triggered manually via the  menu item.</p>
11	<p>Locate the precise position of the fault using a surge wave receiver (e.g. Digiphone) in the area identified during the prelocation.</p> <hr/> <hr/> <div style="display: flex; align-items: center;">  <p>For information about operating the surge wave receiver, refer to the associated operating manual.</p> </div> <hr/> <hr/>

6.9.2 Surge pinpointing up to 50 kV

	<p><b>Wear ear protection</b></p> <p>Surge operation can cause high and sudden noise levels. It is strongly recommended to wear hearing protection during surge operation. Keep in mind that this will limit the operator's awareness for ambient dangers.</p>
---	--

*Procedure* Proceed as follows to perform fault pinpointing:

Step	Action
1	When in the submenu  activate the menu item  or  .
2	Select the defective phase in the phase selection menu and close the menu using  .
3	Set the voltage range to 25 or 50 kV.
4	Use the menu item  to select whether the surge discharges are to be decoupled automatically or manually. With automatic surge decoupling, the desired distance between two surges (surge rate) can be set down to the second using the menu item  .
5	Start the operating mode via the  menu item.
6	Enable the high voltage using the "HV ON" button.
7	Set the surge voltage, taking the required fault ignition voltage into consideration.
8	Start surge operation via the  menu item on the Teleflex VX. <b>Result:</b> In time with the set surge rate, the system couples surge pulses into the test object that result in flash overs at the fault position. In manual surge mode, each surge discharge must be triggered manually via the  menu item.
9	Locate the precise position of the fault using a surge wave receiver (e.g. Digiphone) in the area identified during the prelocation.
<hr/> <div style="display: flex; align-items: center; justify-content: center;">  <p>For information about operating the surge wave receiver, refer to the associated operating manual.</p> </div> <hr/>	

### 6.9.3 Surge pinpointing up to 80/100 kV (optional)

	<p><b>Wear ear protection</b></p> <p>Surge operation can cause high and sudden noise levels. It is strongly recommended to wear hearing protection during surge operation. Keep in mind that this will limit the operator's awareness for ambient dangers.</p>
--	--

*Procedure* Proceed as follows to perform fault pinpointing:

Step	Action
1	Put the test van into operation as described in chapter 3. The electrical connection between cable reel HV3 and the patch panel is to be carried in compliance with the special requirements of the "100 kV surging" mode (see page 26).
2	When in the submenu  activate the menu item  or .
3	Select the defective phase in the phase selection menu and close the menu using . For operation in 80/100 kV mode, refer to the special notes on electrical connection (see page 26) and phase selection (see page 44).
4	Use the menu item  to select whether the surge discharges are to be decoupled automatically or manually. With automatic surge decoupling, the desired distance between two surges (surge rate) can be set down to the second using the menu item .
5	Start the operating mode via the  menu item.
6	Enable the high voltage using the "HV ON" button.
7	Set the surge voltage, taking the required fault ignition voltage into consideration.
8	Start surge operation via the  menu item on the Teleflex VX.  <b>Result:</b> In time with the set surge rate, the system couples surge pulses into the test object that result in flash overs at the fault position. In manual surge mode, each surge discharge must be triggered manually via the  menu item.
9	Locate the precise position of the fault using a surge wave receiver (e.g. Digiphone) in the area identified during the prelocation.
<hr/> <hr/> <div style="display: flex; align-items: center; justify-content: center;"> <p>For information about operating the surge wave receiver, refer to the associated operating manual.</p> </div> <hr/> <hr/>	

## 6.9.4 Line and fault location with the audio frequency generator

*Introduction* The audio frequency generator, in combination with an appropriate audio frequency receiver, is suitable for pinpointing of low resistance cable faults (field of twist method, minimum turbidity method), for locating cables and metallic conductors (for example, pipes) and for cable identification.

With automatic impedance matching, multi-frequency operation and SignalSelect operating mode for showing the direction of flow, the generator provides a number of features that facilitate location/identification and ensure reliable results.

*Coupling to the cable or metallic conductor* When locating/routing metallic lines (e.g. cables, pipes), a signal return current must be ensured through contact with the ground or, if necessary, through connection to an alternative conductor. One possible option is a direct connection to the cable shield. This method eliminates the need for further switching operations at the other end of the cable.



If the shield cannot be isolated from earth at the connection point, the signal can also be directly coupled to the inner conductor. In this case, however, it is recommended that the inner conductor is grounded at the other end of the cable — especially at low frequencies.



Specific connection methods for locating sleeves and faults in twisted multi-core cables are provided in the operating instructions for the audio frequency receiver.

**Selecting the operating mode and phases** At the start of an audio frequency measurement, the submenu of the pinpointing operating modes must be opened using the menu item and from this, the menu item accessed.

Directly upon entering the operating mode, the connected phase to be tested is queried. The phase must then be configured according to the actual connection situation.

The phase selection menu must then be closed using . If necessary, the phase selection can be opened later and modified.

**Setting the operating mode and the measurement parameters** In preparation of the actual measurement, the desired operating mode should be set first:

Operating mode	Description
	Sine wave mode In this default mode, the currently set frequency is normally emitted as a pure sine wave.
	“SignalSelect” mode In “SignalSelect” mode, a specially coded audio frequency signal is emitted that identifies the direction of the signal flow, thus increasing the accuracy and reliability of route tracing. The mode is thus perfectly suited for routing of conductors in areas with lines that run close together. Reliable identification of the coded signal can only be ensured when no customer-specific frequencies are preconfigured on the audio frequency generator, instead only the standard frequencies (see following table).
	Multi-frequency mode In multi-frequency mode, the frequencies $f_1$ , $f_2$ and $f_3$ are emitted parallel and superimposed.

Depending on the set operating mode, the following parameters can be set:

Menu item	Description
	Setting of the output frequency with which the metallic conductor should transmit. By default, the frequencies 0.488 kHz ( $f_1$ ), 0.956 kHz ( $f_2$ ) and 8.867 kHz ( $f_3$ ) are offered. Upon request, other/additional ones can be activated (in total up to 5 frequencies between 0.400 and 9.999 kHz are possible).
	Switch between continuous and pulse mode In pulse mode, after 700 ms, the output signal is interrupted for 300 ms. This timing can be useful for disturbed and superimposed signals in order to be able to clearly identify your own signals. Due to special coding of the output signal, in “SignalSelect” mode, no pulsed signal can be emitted.

**Starting audio frequency transmission** Once all relevant parameters have been set, transmission along the metallic conductor can be started using the menu item . Following this the high voltage must be authorized using the “HV ON” button and the transmission power set. The dialogue for setting the power level closes automatically after a few seconds for safety reasons but it can be accessed again using the menu item  $P_{NOM}$ .

As soon as high voltage is enabled, the “HV OFF” button lights up red signaling “high voltage at the HV output”. The audio frequency signal is transmitted on the connected conductor.

*Line and fault location* During line and fault location, the test van must not be left unattended and accessible to third parties.

The measurement technician who remains in the test van can maintain telephone contact with their colleagues and if necessary, modify the operating mode or frequency.

For line and fault location, any audio frequency receiver whose reception frequencies match the frequencies of the generator is in principle suitable. For clear identification of the specially coded "SignalSelect" signal (and thus the signal direction of flow), however, an audio frequency receiver from the product assortment of Megger is necessary.



For detailed information on using the audio frequency receiver and the various location methods, please read the accompanying instructions.

---

---



**WARNING**

**Risk of electric shock**





The safety of the test van that is in operation must be guaranteed at all times by the persons responsible for the test van in accordance with the applicable safety regulations and guidelines, also during line and fault location!

### 6.10 Sheath test and sheath fault location with the MFM 10-M / HVB 10-M (optional)

**Requirements** The test van must be equipped with an **MFM 10-M** sheath fault location system or an **HVB 10-M** high voltage measuring bridge.

**Purpose** The MFM 10-M as well as the HVB 10-M allow the operator to check cable sheaths in the easiest manner possible, as well as the prelocation and pinpointing of sheath faults with a bipolar test voltage of up to 10 kV.

**Procedure** Proceed as follows to perform sheath testing or sheath fault locating:

Step	Action
1	Put the test van into operation as described in chapter 3. Use the MFM/HVB connection cable (see page 28) for the connection to the test object.
2	When in the submenu  activate the menu item  .
3	Select the connected phase in the phase selection menu and close the menu using  .
4	Start the operating mode via the  menu item.
5	Enable the high voltage using the “HV ON” button.
6	Switch on the MFM 10-M or the HVB 10-M and carry out the desired tests.
 For information on operating the MFM 10-M or the HVB 10-M, refer to the corresponding operating manual.	

### 6.11 Completing the work

After the measurements on a cable system has been completed and the high voltage has been switched off (see page 36), the test van can be switched off by pressing the main switch button **7** on the Control Panel.

When disconnecting the test system, proceed in reverse sequence to the manner in which the connection (see page 21) was made.

## 7 Exporting and processing measurement data

After the actual measurement job, the recorded measurement data can be conveniently analysed, archived and summarised in a report on a Windows PC.

To do this, the desired data must first be marked for export in the History database (see page 45) and then exported to an inserted USB flash drive via the data menu (see page 51). On the Windows PC, the data can then be imported into the protocol software and processed further. Depending on the version of the protocol software, the following functions are available:

	<b>Megger Book Lite</b> <small>(free download on the Megger website)</small>	<b>Megger Book</b> <small>(full version)</small> <small>(article number: 2015875)</small>
Analysis of the measurement data with practical tools	●	●
Creation of a report based on extensively customisable report templates	●	●
Creation and maintenance of a cable database		●
Archiving of measurement activities in the data stock of the respective cable		●

## 8 Troubleshooting

**Fault messages** A range of error messages can occur at the Teleflex VX during measurement, which can be assigned to the following error categories:

- Procedure could not be completed because of a timeout
- Overvoltage determined at a surge capacitor
- Switching procedure could not be carried out or completed
- A shortfall of the minimum gas pressure in the HV motor switch or in the discharge and earthing switch has been detected.

	<p><b>WARNING</b></p> <p><b>Risk of electric breakdown</b></p> <p>If a non-permissibly low gas pressure is signaled for one of the two switches, its inner dielectric strength is no longer guaranteed at extremely high voltages. No voltage &gt; 50 kV may be generated with the system until the gas in the affected switch has been refilled by an authorised service centre.</p>
---	---

In the event of a malfunction, the test van must be switched off taking the five safety rules (see page 9) into consideration. Discharging of the test van and the test object is not guaranteed in this case and must be carried out manually using a suitable discharge rod if necessary!

**Behaviour at malfunction of normal operation** The equipment may only be used when working properly. When irregularities or malfunctions appear that cannot be solved consulting this manual, the equipment must immediately be put out of operation and marked as not functional. In this case inform the person in charge who should inform the Megger service to resolve the problem. The instrument may only be operated when the malfunction is resolved.

**Checking the fuses** If a failure occurs in the power supply of the individual devices or peripherals, the positions of the circuit breakers and the fuses should first be checked.

The fuses of the measuring system are located in the leg area below the Teleflex VX and arranged as follows:



F1                      F2      F3      F4      F5                      F6                      F7      ...      F15

Fuse	Rating	Protection
F1	2 x 25 A	Mains input
F2	25 A	Generator input
F3	16 A	Air conditioning system, fan heater
F4	16 A	Plug socket
F5	16 A	Mains HV devices
F6		FI circuit breaker, plug sockets, charger, air conditioning system
F7	2,5 A	24 V power supply 1 to supply safety circuit and motor control
F8	2 A	Main switch
F9	4 A	Battery charger
F10	8 A	24 V power supply 2 to supply the PLC (programmable logic controller)
F11	1 A	PCB U/I transducer and PCB EL/PE
F12	4 A	Teleflex VX, control of high voltage source
F13	4 A	PLC
F14	8 A	Safety circuit
F15	6,3 A	Motor control unit

Especially in the event of power supply problems, the fuses in the NAS 60-3 mains supply system should also be checked. This is located at the end of the mains cable.

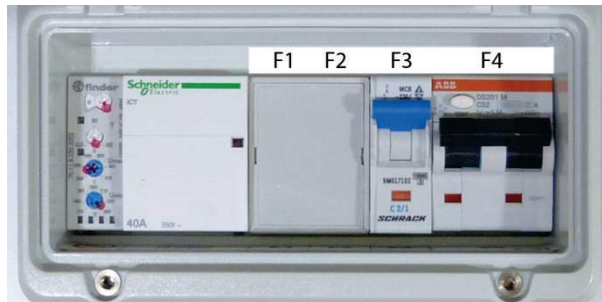

Fuse	Value	Function
F1/F2	DG MOD 275	Overvoltage protection
F3	C2	Voltage monitoring
F4	RCD C32/0.3 A	Test van main circuit
F5/F6 (inside the housing)	T1A	Indicator lights on the NAS 60-3

Some other relevant 12 or 24 V circuits (e.g. vehicle interior lighting, cable drum motor) are protected by the vehicle fuses.

	<p><b>CAUTION</b></p> <p>If a circuit breaker or fuse is tripped repeatedly, it must be assumed that there is a permanent fault in the affected circuit. To prevent additional damage, further operation of the test van is not allowed.</p>
---	--

## 9 Care and Maintenance

### 9.1 Required maintenance by a service workshop

A measurement system of the technical complexity of the System R 30 needs regular maintenance to maintain its functionality. For this reason, it is **imperative** to perform a maintenance upon occurrence of one of the following conditions:

- Once a year (check of the HV components, the safety devices, the insulating gas and the individual devices / accessory parts)
- In case of malfunctions
- If the gas pressure in the HV motor switch or discharge and earthing switch drops below the minimum threshold

Upon occurrence of any of these conditions, promptly contact the responsible service workshop to make an appointment for maintenance.



If the maintenance requirements described above are not fulfilled, the manufacturer releases itself from the warranty on defects shown to be due to inadequate maintenance.

### 9.2 Maintenance work you can carry out yourself

To identify possible problems at an early stage and keep the system in good condition, you must carry out the following tasks yourself at appropriate intervals depending on use:

- Remove dust and dirt
- Check the function of door and EMERGENCY OFF switches
- Unwind the cables and inspect for cracks and damage
- Check connecting cables and HV components for secure hold



For information on do-it-yourself maintenance and care of peripheral devices, read the corresponding sections in the relevant operating manuals. This especially applies to battery-powered devices.



If you find any defects during the test, promptly inform a service workshop authorised by Megger.